

APACHETM

A5650

2025 Operator's Manual



**DO NOT OPERATE THIS EQUIPMENT UNTIL THIS MANUAL HAS BEEN READ AND UNDERSTOOD.
ONLY PROPERLY TRAINED PERSONS SHOULD OPERATE THIS MACHINE.**

**EQUIPMENT
TECHNOLOGIES** 

FORM # 580525000
COPYRIGHT 2024
EQUIPMENT TECHNOLOGIES

Apache Sprayer Information

The password for the locked screens on the ET Pilot Touchscreen is "2201".

Dealer: _____

Main Phone# _____

Service Contact: _____

Phone # _____

Parts Contact: _____

Phone # _____

Shop Contact: _____

Phone # _____

Sales Rep: _____

Phone # _____

Precision Rep: _____

Phone # _____

ET / Apache Phone #: _____

Guidance Width/Inches:

of Sections: _____

Boom 1 Cal: _____

Boom 2 Cal: _____

Boom 3 Cal: _____

Boom 4 Cal: _____

Boom 5 Cal: _____

Boom 6 Cal: _____

Boom 7 Cal: _____

Boom 8 Cal: _____

Boom 9 Cal: _____

Product Control:

Speed Cal#: _____

Valve Cal#: _____

Meter Cal#: _____

Valve Advance: _____

Valve Delay: _____

Section Control:

On Look Ahead: _____

Off Look Ahead: _____

Machine Model: _____

Machine Serial #: _____

Engine Serial #: _____

Rate Controller Model: _____

Aux Controller/Display: _____

GPS Antenna Model: _____

GPS Source: _____ GPS Satellite: _____

Height Control: _____

Software Version: _____

Offset: LH Outer: _____ LH Inner: _____

Center: _____ RH Inner: _____

RH Outer: _____

Sensitivity: _____ Speed: _____ Stability: _____

Autosteer: _____ Module Orientation: _____

Software Version: _____

Implement Offsets:

Fore/Aft: _____ Height: _____

Wheelbase: _____

Low Limit/Minimum Flow:

Nozzle Size/Color/Rate _____ = _____

Nozzle Size/Color/Rate _____ = _____

Nozzle Size/Color/Rate _____ = _____

Nozzle Size/Color/Rate _____ = _____

** To maintain minimum spray pattern adjust when changing nozzle size.*

Dear Valued Customer,

Congratulations on the purchase of your new Apache Sprayer, and welcome to the Apache family of owners! We hope that your new Apache Sprayer exceeds your expectations, and gives you years of satisfaction. We invite you to visit us at www.etsprayers.com or in person at our plant in Mooresville, Indiana.

On behalf of all of our employees, we thank you for your business!

Yours Faithfully,



Matthew F. Hays
Chief Executive Officer

NOTICE

Before operating your Apache Sprayer, please check and calibrate the following precision agricultural equipment depending on the machine configuration. Always operate the Apache within the state and local guidelines and regulations.

1. Check all settings and calibrations in your field computers:
 - Swath Width
 - Boom Section Calibration
 - Receiver Fore/Aft Settings
 - Valve Calibration
 - Rate Calibration
 - Low Limit Setting
2. Please review your boom height control and boom spray control settings, if equipped.
3. Please review your plumbing recirculation settings, if equipped.
4. Calibrate the autosteer if equipped. Autosteer calibration must be performed on a large, flat, and open area. Make sure all settings are entered properly, and that calibration is performed in its entirety. This includes driving on an A-B line for roughly 20 minutes after automatic calibration is completed to allow the yaw sensor to learn how to acquire the line properly.

Trademark Information

Ag Leader®

- InCommand™
- SteerCommand Z2™
- DirectCommand® L2
- RightSpot™

CapstanAg®

- PinPoint® III

Caterpillar®

- Cat® TDTO 30

Cummins®**Equipment Technologies (ET)**

- Apache™

Goodyear®**John Deere®**

- Autotrac™

Lucas® Oil Products**Michelin®****NORAC**

- UC7™

Raven Industries

- AccuBoom™
- AutoBoom®
- Raven Boom Recirculation™
- RS1® AutoSteer
- Viper® 4+

Chapter 1: General Information

2025 AS650 Specifications	1-1
Apache AS650 Fluids, Filters and Capacities	1-2
Safety Symbols, Signal Words and Statements	2-1

Chapter 2: Safety

Safety Precautions	2-2
Pre-Operation Hazards	2-2
Fire and Explosion Hazards	2-2
Burn Hazards	2-3
Lifting Hazards	2-3
Exposure Hazard	2-3
Entanglement / Sever Hazard	2-3
Alcohol and Drug Hazard	2-3
Exhaust Emissions Safety	2-4
Environmental Precautions	2-4
Safety Belt	2-4
Safety Decals	2-5
Decal Locations	2-6
Pre-Operation Checks	3-1

Chapter 3: Operation

Transporting and Trailering Apache Sprayer	3-2
Removal of Front Axle Locking Bars	3-2
Storage of Locking Bars	3-2
Cab Overview	3-3
Cab Access Ladder	3-4
Steering Column	3-4
ET Pilot System	3-5
ET Pilot System Touch Screen	3-6
Diagnostics Page 1: Vehicle Warnings	3-8
Active Faults	3-8
Fault History	3-9
Clear Fault History	3-9
Diagnostics Page 2: Parameters	3-10
Scheduled Maintenance App	3-10
General Maintenance App Page	3-10
Interval Maintenance App Page	3-11
Maintenance Entry	3-11
Maintenance Reminders	3-11
Vehicle Settings Page 1:	3-12
Vehicle Settings Page 2:Version Information	3-13
Vehicle Settings Page 3: Front Suspension (Airbag) Calibration	3-13
Vehicle Settings Page 4: ET AutoFold (If Equipped)	3-15
Calibrate AutoFold Feature	3-15
Vehicle Settings Page 5: Configuration	3-17
Light Switches	3-18
Apache Sprayer Lighting	3-18
AM/FM Radio with Weather Band and Streaming Player	3-19
Accessories	3-19
Seat Adjustment	3-20
Leather Seat	3-20

Joystick and Universal Terminal Console	3-21
Interior Decal Location	3-21
Starting and Stopping the Engine	3-22
Starting	3-22
Warm-up	3-23
Stopping	3-23
Apache Sprayer Direction and Speed	3-24
Neutral	3-24
Forward	3-25
Shifting Forward Gears	3-25
Reverse	3-26
Exhaust Braking	3-27
Cruise Control	3-27
Towing	3-28
Hood Tilt Latch	3-28
Battery	3-29
Climate Controls	3-30
Precision Equipment	3-30
Antenna Mounting Plate	3-31
Rear Camera	3-32
Jump-starting the Engine	3-33
Exhaust Cleaning	3-34
Automatic Cleaning	3-34
Disabled Mode	3-35
Manual Cleaning	3-36
Low DEF Fluid	3-37
Vehicle Dynamics	3-40
Boom Rack	3-40
Rack Lock	3-41
Rack Leveling (Manual)	3-43
Rack Leveling (Auto Level)	3-43
Rack Manifold Cleanout	3-43
Rack Angle Calibration	3-44

Chapter 4: Wet System Operation

Wet System Overview	4-1
Fill Station	4-2
Key Pad Functions	4-2
Electric Valve Operation	4-3
Button Feature Decal	4-3
Touch Screen Controls	4-4
Touch Screen and Keypad Summary	4-4
Product Pump and Valves	4-5
Sump Valve	4-5
Flow Control	4-5
Electronic Boom Valves	4-7
Viper® 4+ Monitor	4-7
Side Console	4-8
Joystick	4-8
Filling Product Tank	4-9
Filling Rinse Tank	4-9
Operating Booms	4-10
Tilt to Remove Boom from the Cradle	4-10
Unfold Boom Wings	4-10
Unfold Boom Tips	4-11
Height Adjustment	4-11

Tilt to Level Boom 4-11
 Fold Boom Tips 4-11
 Fold Boom Wings 4-12
 Tilt to Return Boom to Cradle 4-12
 AutoFold (If Equipped) 4-12
 Unfold 4-13
 Fold 4-13
 Spraying 4-14
 Quick Spray Mode (Compatible with Raven
 Spray Control Module only) 4-16
 Optional Fence Row Nozzle 4-17
 Flushing Product Tank 4-17
 Flushing Booms 4-18
 Cleanload Chemical Eductor 4-19
 Startup 4-19
 Loading Liquid or Powdered Chemical
 into Hopper 4-19
 Boom Recirculation (Optional Equipment) 4-20
 Operation 4-20
 Required Conditions for Recirculation 4-21
 Auto-Recirculation 4-22
 Setup (Raven Boom Recirculation Specific) .. 4-22
 What To Expect While
 Recirculation Is Active 4-23
 Setup (CapstanAg PinPoint III Boom
 Recirculation Specific) 4-24
 Setup (AgLeader Rightspot Boom
 Recirculation Specific) 4-24

Check Rear Differential for Leaks 5-17
 Check Final Drive Fluid Level 5-17
 After First 100 Hours 5-18
 Every 100 Hours 5-18
 Grease Driveline Components 5-18
 Check Torque on Rear Axle Lower
 Torque Arm Mounting Plate Bolts 5-19
 Every 250 Hours or Yearly 5-20
 Clean or Change Engine Primary Air Filter . . . 5-20
 Change Differential Fluid 5-21
 Change Hydraulic Fluid Filter 5-21
 Every 500 Hours or Yearly 5-23
 Change Primary Fuel Filter 5-23
 Change Secondary Fuel Filter 5-23
 Change Engine Oil and Filter 5-24
 Change Transmission Oil and Filter
 and Clean Strainer 5-25
 Inspect and Repack Wheel 5-26
 Change Final Drive Fluid 5-26
 Change Cab Charcoal Filter 5-27
 Every Year 5-28
 Adjust Toe-In 5-28
 Change Engine Safety Air Filter 5-29
 Winterize Wet System 5-29
 Every 1000 Hours or Yearly 5-31
 Change Hydraulic Fluid 5-31
 Change DEF Suction Strainer 5-32
 Every 2000 Hours 5-33
 Change Crankcase Ventilation Filter 5-33
 Every 4500 Hours or 3 Years 5-33
 Change DEF Supply Module Filter 5-33

Chapter 5: Lubrication and Maintenance

Maintenance Precautions 5-1
 Environmental Precautions 5-3
 Non-Apache Equipment Maintenance 5-3
 Cleaning Guidelines 5-4
 Mechanical Parts 5-4
 Electrical Parts 5-4
 Body and Cab Exterior 5-4
 Apache Sprayer Service Interval Chart 5-5
 Before Initial Use 5-6
 After First 10 Hours 5-6
 Adjust Boom 5-6
 As Required 5-9
 Daily 5-9
 Grease Boom 5-10
 Flush Wet System 5-12
 Check Tire Pressure 5-12
 Check Engine Oil Level 5-12
 Check Cooling System 5-13
 Check Transmission Oil Level 5-14
 Check Hydraulic Fluid Level 5-15
 Drain Primary Fuel Filter 5-15
 Every 40 Hours 5-16
 Adjust Poly Tank Straps 5-16
 Torque Lug Nuts 5-16
 Grease King-pins 5-16
 Check Differential Fluid Level 5-17

Chapter 6: Torque Value Charts

Fittings 6-1
 Bolts 6-3

Chapter 7: Troubleshooting

Apache Sprayer Troubleshooting Symptoms
 and Solutions 7-1

Chapter 8: Electrical System

Fuse and Relay Diagrams 8-1
 Chassis - Fuse Diagram 8-2
 Cab - Fuse Diagram 8-3

Chapter 9: Warranty

Apache Sprayer Warranty Registration and Policy
 For all 2025 Model Year 9-1

Chapter 10: Maintenance Log

APACHE™

CHAPTER 1

GENERAL INFORMATION

The graphics and text in this manual generally describe the AS650 Apache Sprayer. Apache Sprayers differ by model and by optionally installed equipment. Your Apache Sprayer may not exactly match the graphics and/or text descriptions in this manual. Please contact your dealer or Equipment Technologies with any questions regarding this manual, or the instructions within it.

2025 AS650 Specifications

	AS650
Tank Capacity	650 gallons [2460 liters]
Engine	163 hp T4-F QSB 4.5L Cummins
Transmission	JCB Power shift 4-speed, torque converted
Speed Ranges	1st 0-5 mph [0-8.04 km/h] 2nd 0-9 mph [0-14.5 km/h], 3rd 0-16 mph [0-25.7 km/h] 4th 0-28 mph [0-45 km/h]
Brakes	Internal, wet disc, self-adjusting
Suspension	Active Airbags with independent front suspension
Cab	ET custom pressurized cab
Crop Clearance	48 in. [121.92 cm]
Axles	90 in [228.6 cm] Fixed Width Axle (Standard) 108 in [274.3 cm] Fixed Width Axle (Optional) 114 in [289.5 cm] Fixed Width Axle (Optional) 120 in [304.8 cm] Fixed Width Axle (Optional)
Final Drive	JCB all gear drop box
Weight	Dry Weight: 16,900 lb [7665.7 kg] (90" axle); 17,200 lb [7801.8 kg] (120" axle)
Fuel Capacity	78 gallons [295.3 liters]
Width	13 ft [4.0 m]
Length	24 ft [7.3 m]
Height	144 in. [365.7 cm]
Wheel Base	13 ft [4.2 m]
Turning Radius	17 ft [5.1 m]
Standard Tires	Front: 380/80R38 and Rear: 380/90R46
Booms	Steel: 60 / 90 ft [18.2 / 27.4 m] Pommier Aluminum: 90 ft [27.4m] and 100 ft [30.4m]
Boom Height	24 to 95 in [61 to 241.3 cm] (48 in CC [121 cm])
Product Pump	ACE 205F-HYD-304, hydraulically driven centrifugal pump
Rotoflush	Pump pressured

Apache AS650 Fluids, Filters and Capacities

Component	Lubrication	Capacity	Filter Part Number
Engine Oil	Lucas 15W-40 Magnum Motor Oil	11.6 quarts [11 liters]	201450241
Engine Coolant	Fleetguard ES Complete OAT Nitrite Free	24 quarts [22.7 liters]	----
Engine Primary Air Filter	----	----	230000001
Engine Safety Air Filter	----	----	230000002
Transmission	Lucas Universal Hydraulic Fluid	16 quarts [15 liters]	300000101
Differential (Rear Axle)	Lucas Universal Hydraulic Fluid	90" Axle: 3.5 gallons [13.2 liters] 108" and 114" Axle: 4.3 gallons [16.3 liters] 120" Axle: 5.5 gallons [20.8 liters]	----
Rear Drop Box	Lucas 80/90 Gear Oil	21 quarts [20 liters]	----
Engine Fuel	Diesel	78 gallons [295.3 liters]	Filter: 261000003 Separator: 211000000 Tank Strainer: 201450001
Diesel Exhaust Fluid (DEF)	----	5 gallons [19 liters]	DEF Supply Module: 241000009 DEF Tank Suction Screen: 241000008
Hydraulic System	Lucas Universal Hydraulic Fluid	23 gallons [87 liters]	880000026
A/C System	R134a	2.8 lbs	----
Cab Filters	----	----	Charcoal Filter: 490003651

NOTE: Any oil and fluid substitutions must meet or exceed recommended fluid specifications.

Michelin Tire Pressure (Cold)

380/80R38 (Agribib)25 psi [2.3 bar]

380/90R46 (Spraybib)46 psi [3.2 bar]

Lug Nut Torque

All Wheels420 lb-ft [570 N•m]

Wet System Capacities

Product Tank AS650 650 gallons [2460.5 liters]

Rinse Tank 50 gallons [190 Liters]

Hydraulic Pump Output 2400 psi [165 bar]

APACHE™

CHAPTER 2 SAFETY

Apache is committed to the safe design and operation of its products. This Apache Sprayer has been designed and manufactured with your personal safety while operating this Apache Sprayer as a primary concern.

Safety Symbols, Signal Words and Statements

Safety symbols, signal words and statements, and symbols are used in this manual and on the Apache Sprayer to identify and alert you of potential hazards where personal safety precautions are required.



The safety alert symbol is used to alert you of potential personal injury hazards. Carefully read the safety message associated with safety symbol and follow any instructions provided to ensure your safety.

Safety signal words are used to alert you of potential personal injury hazards. Carefully read the safety message associated with safety signal word and follow any instructions provided to ensure your safety.

Safety statements are used to explain and inform you of potential personal injury hazards and provide precautionary instructions. Read, understand and follow

all safety messages and information contained in this manual and on the Apache Sprayer to prevent personal injury and ensure safe reliable Apache Sprayer operation.

 **DANGER**

Indicates a hazardous situation which, if not avoided, will result in death or serious injury.

 **WARNING**

Indicates a hazardous situation which, if not avoided, could result in death or serious injury.

 **CAUTION**

Indicates a hazardous situation which, if not avoided, could result in minor or moderate injury.

*The italicized **NOTICE**, indicates a potentially hazardous situation which, if not avoided, may result in improper Apache Sprayer operation and/or damage to equipment, property and the environment.*

Safety Precautions

There is no substitute for common sense and following careful operation and service practices. Improper practices and carelessness can cause personal injury or even death.

The following safety precautions and guidelines must be followed in addition to the specific safety precautions listed throughout this manual and on the Apache Sprayer to reduce the risk of personal injury.

Keep this manual and all included literature in a safe and convenient location. Contact your Apache dealer or Apache at (800) 861-2142 to obtain replacement owner's manuals and safety decals.

To ensure your safety, the safety of others, and the safe operation of the sprayer, read, follow and practice the following:

WARNING

The safety messages that follow have WARNING level hazards.

Pre-Operation Hazards

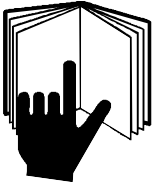

Read and understand this Owner's Manual before operating or servicing the Apache Sprayer to ensure that safe operating practices and maintenance procedures are followed. If you do not understand any part of this manual and need assistance, see your Apache dealer for assistance.

- ***NEVER permit anyone to operate the Apache Sprayer without proper training. Obtain proper knowledge and training before attempting to perform any operation or service procedure in this manual.***
- ***This Apache Sprayer and its attachments are designed to spray liquid product. Use of this Apache Sprayer in any other manner other than its intended use is prohibited.***
- ***DO NOT operate sprayer on public highways with fluid in product tank.***
- ***Remove or clean contaminated clothing before entering the cab.***
- ***Some components and systems of Apache Sprayers are manufactured by companies other than Apache and have specific safety, inspection, adjustment and maintenance procedures outlined by their manufacturer. Carefully read and understand all non-Apache Sprayer and sprayer manufacturer instructions and manuals supplied with the Apache Sprayer. These include, but are not limited to the Engine Owner's Manual, Sprayer Monitor System Manual, Radio Manual, Chemical Eductor Manual, Product Pump Instructions and other optional equipment.***

Fire and Explosion Hazards



Diesel fuel is flammable and explosive under certain conditions. Store any containers containing fuel in a well-ventilated area, away from any combustibles or sources of ignition.

- ***NEVER use a shop rag to catch spilling fuel.***
- ***Wipe up all fuel spills immediately.***
- ***NEVER refuel with the engine running.***
- ***ALWAYS have appropriate safety equipment available. Have all fire extinguishers checked periodically for proper certification, operation and/or charge capacity.***
- ***ALWAYS read and follow safety-related precautions found on containers of hazardous substances like parts cleaners, primers, sealants and sealant removers.***

Burn Hazards



Some of the engine surfaces become very hot during operation and shortly after shut-down. Keep hands and other body parts away from hot engine surfaces.

Lifting Hazards

- *ALWAYS use lifting equipment with sufficient capacity to lift the Apache Sprayer or equipment.*
- *If transport is needed for repair, acquire assistance when using a hoist and when loading and unloading.*

Exposure Hazard

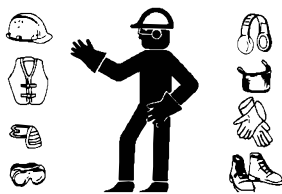

ALWAYS wear the appropriate personal protective equipment as required by the task at hand, including but not limited to:

- *Relatively tight and belted clothing*
- *Safety gloves*
- *Safety shoes/boots*
- *Safety eye glasses/goggles/shields*
- *Hearing protection, ear plugs*
- *Head protection, hard hats*
- *ALWAYS wear a respirator, goggles and gloves in addition to wearing long shirt sleeves and long pants when handling chemicals. Read the chemical safety label or instructions before usage.*

Entanglement / Sever Hazard



NEVER wear jewelry, watches, unbuttoned cuffs, ties or loose-fitting clothing and ALWAYS tie long hair back when working near moving/rotating parts.

- *ALWAYS Keep hands, feet, hair and clothing away from all moving/rotating parts.*
- *NEVER operate the engine without the guards in place.*



Alcohol and Drug Hazard

- *DO NOT operate or service the Apache Sprayer while under the influence of alcohol, awareness-altering drugs or medications that would affect your ability to operate or maintain the sprayer safely.*

Exhaust Emissions Safety

Carefully read all safety information and observe any exhaust or pollution safety instructions. Be aware of and follow all regulations and policies as outlined by the engine OEM to maintain exhaust emission compliance with the Environmental Protection Agency (EPA), California Air Resources Board (CARB) and Environment Canada where applicable.

It is the owner's responsibility to keep the Apache Sprayer maintained and within compliance.

The state of California, U.S., has special regulations that may exceed the EPA regulations. If the Apache Sprayer is operated or serviced in the state of California, observe all exhaust and pollution regulations.



WARNING! Exhaust Gas Exposure Hazards

- **All internal combustion engines create carbon monoxide gas during operation and special precautions are required to avoid carbon monoxide poisoning. Prolonged exposure to carbon monoxide will cause brain damage or death.**
- **ALWAYS operate the engine outside in a well-ventilated area.**
- **NEVER block windows, vents or other means of ventilation if the engine is operating in an enclosed area.**
- **ALWAYS ensure that all connections are tightened to specifications after repair is made to the exhaust system.**

Environmental Precautions

The safety messages that follow have NOTICE level hazards.

- *Thoroughly clean any spilled fluids from the equipment and/or ground after service is completed. Dispose of used fluids and filters as required by law.*
- *ALWAYS be environmentally responsible. Follow the guidelines of the EPA or other governmental agencies for the proper disposal of hazardous materials such as engine oil, diesel fuel and engine coolant. Consult the local authorities or reclamation facility.*
- *NEVER dispose of hazardous materials by dumping them into a sewer, on the ground, or into ground water or waterways.*

Safety Belt



WARNING! Impact Hazards.

- **ALWAYS fasten your seat belt when operating the Apache Sprayer. The safety belt must be worn properly by the driver anytime the Apache Sprayer is in motion.**
- **NEVER alter or tamper with any safety belt system components.**

Safety belt systems are designed to limit occupant motion by restraining occupants' bodies within the cab and prevent, or reduce the severity of, injuries during most types of collisions. When safety belts are used properly, they are effective in reducing the risk of injury.

Inspect the safety belt system regularly for cuts, frays, wear, discoloration or abrasion. The hardware, mounts, retractor and belt should work freely. The belt and/or components must not show signs of deterioration. If you suspect any part of the system is in need of repair, have the system repaired or replaced immediately and use only parts designed for the safety system.



WARNING! Impact Hazard

DO NOT operate the Apache Sprayer if any part of the seat belt system is damaged. The system must be repaired or replaced before operating the Apache Sprayer.

NOTICE: *DO NOT use harsh cleaners, bleach or any products which could cause the safety belt material to deteriorate.*

Safety Decals



CAUTION!

ALWAYS read and follow the safety decals on the Apache Sprayer. Safety decals are additional reminders for safe operating and maintenance techniques.

Safety decals are used to explain and inform you of potential personal injury hazards and provide precautionary instructions. Read, understand and follow all safety decals on the Apache Sprayer to prevent personal injury and ensure safe reliable Apache Sprayer operation.

NOTICE: Prevent safety decals from becoming dirty or damaged and replace them immediately should they become damaged or are missing. Should an Apache Sprayer part that has a decal attached to it need replacement, obtain a new decal with the new part.

Contact your Apache dealer or Apache at (800) 861-2142 to obtain replacement safety decals.

To ensure your safety, the safety of others and the safe operation of the sprayer, read, follow and observe the following safety decals.

Decal Locations

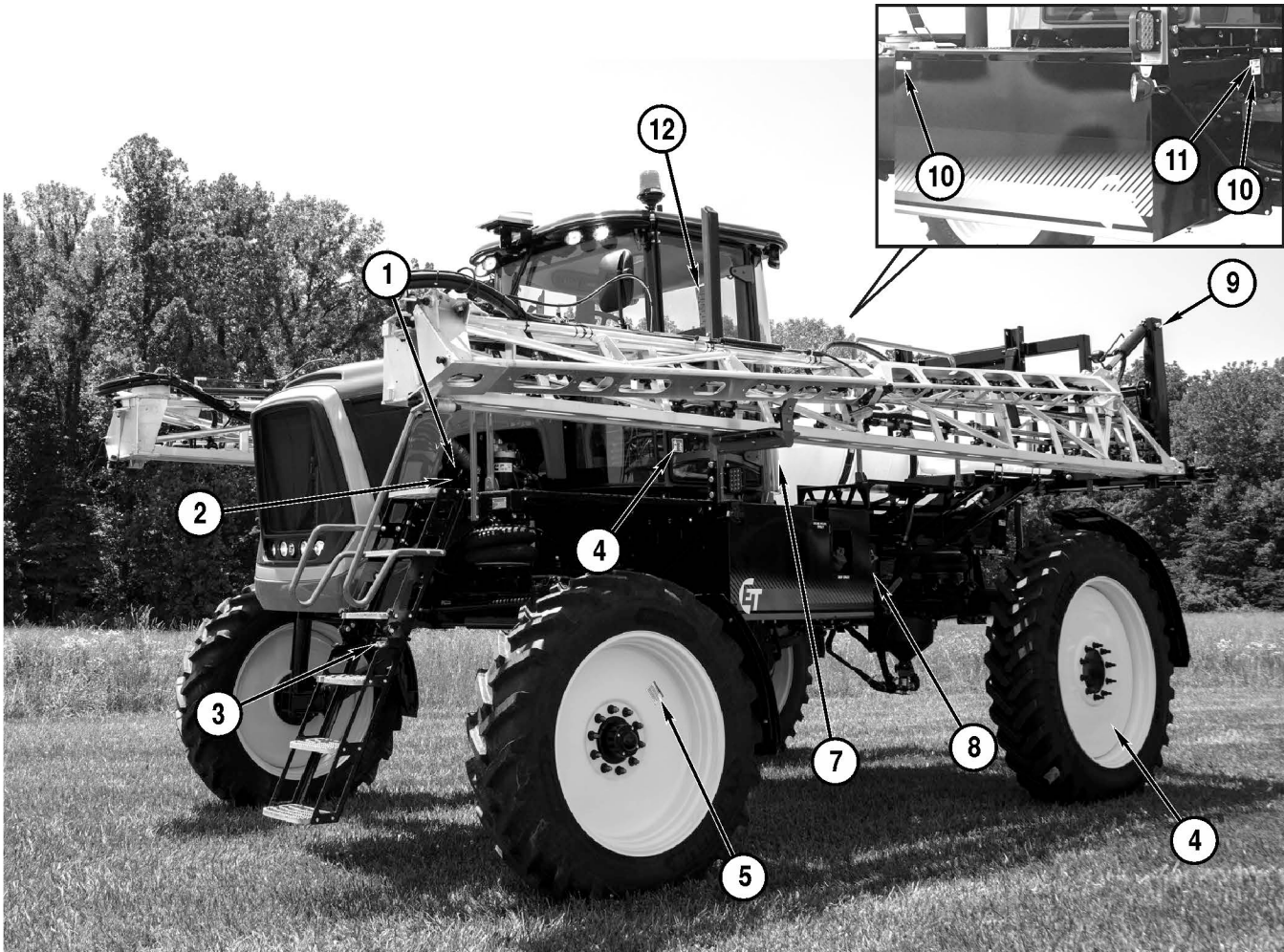

1.  **⚠ WARNING**
ROTATING FAN BLADES
 • Keep clear while engine is running
 • Contact may result in personal injury or death
 472000037

2.  **⚠ WARNING**
BURN / SEVER HAZARD
 Keep fingers clear of hot surfaces and rotating parts while engine cover is open and engine is running.
 420306036

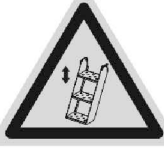
3.  **⚠ WARNING**
STRIKING BYSTANDER HAZARD
 Keep bystanders away from automatic ladder; it may move unexpectedly.
 420306059

4. 

5. **⚠ WARNING**
TIRE HAZARD
 • Torque wheel bolts to 420 ft-lb (570 N•m). Check torque daily for first week of operation and weekly thereafter.
 • Replacement tire must meet or exceed original tire specifications. Failure to comply may cause tire failure resulting in serious injury or death.
 420306033

Decal Locations (continued)

6. **HAND RINSE** (hand rinse tank not shown in image)

7. **WARNING**
Never climb inside tank
47200028

NOTICE
1. Tighten bolts on each tank strap without pulling the top of the tank down or bending the bolts or tank skid.
2. Tighten tank straps evenly side-to-side.
3. Fill the tank with water.
4. Drive tractor.
5. Allow tank to settle.
6. Retighten straps.
7. Inspect straps daily.
47200027

8. **WARNING**
HIGH-PRESSURE FLUID HAZARD
High-pressure hydraulic fluid leaks can penetrate skin resulting in serious injury, gangrene or death.
• Check for leaks with cardboard; never use your hand.
• Before you loosen a fitting:
- Lower load.
- Release pressure.
- Make sure hydraulic fluid is cool.
• Consult physician immediately if skin penetration occurs.
42030413

WARNING
EXPOSURE HAZARD
Agricultural chemicals can be dangerous:
• Improper selection or use can seriously injure persons, animals, plants, soil or other property.
• Select the correct chemical for the job.
• Handle the chemicals with care.
• Follow the instructions on the container label and instructions from the equipment manufacturer.
42030418

WARNING
NON-POTABLE WATER HAZARD
This water is for rinsing or washing purposes only. Do not drink it. It may be contaminated by sprayer chemicals. Fill with clean water only.
42030402

WARNING
ENTANGLEMENT HAZARD
Keep body parts away from rotating driveshaft.
42030408

NOTICE
• Fill the rinse, foamer or product tank slowly.
• Rapidly filling, or overfilling, any of these tanks may cause them to rupture.
42030414

9. **WARNING**
Pinch Point
Keep hands clear during operation.
47200034

10. **WARNING**
Falling Hazard
• No guardrails present
• Not to be used as walking surface
47200031

11. **WARNING**
BURN HAZARD
Keep hands away from the muffler and exhaust system until the engine is completely cool.
420306058

12. **DANGER**
ELECTROCUTION HAZARD
• This machine is not insulated.
• Death or serious injury will result from contact with or inadequate clearance to electrical power lines and apparatus.
• Maintain safe clearances from electrical power lines in accordance with applicable government regulations such as OSHA 1910.269.
• This machine does not provide protection from contact with or proximity to an electrically charged power line.
420306050

WARNING
STRIKING OBJECT OR BYSTANDER HAZARD
Do not fold or unfold booms while sprayer is moving.
420306054

WARNING
OPERATIONS HAZARDS
• Do not operate sprayer on public highways with fluid in product tank.
• Always drain and flush tank prior to transport.
• Do not exceed 40 mph unloaded.
420306052

WARNING
OPERATIONS HAZARDS
• Read and understand operator's manual before operating, servicing or repairing the tractor. Follow all safety rules and instructions. Manuals are available from dealer.
• Only operate tractor from operator's seat with seat belt securely fastened.
• Before leaving the operator's seat, place machine in neutral position, apply parking brake, and stop engine.
• Do not allow children or untrained persons to operate the equipment.
• Reduce speed when turning or operating around hazards, on rough ground or steep slopes.
• Use flashing warning lights on highways unless prohibited by law.
420306051

WARNING
FALLING HAZARD
Never allow riders outside of the cab while operating machine.
420306030

NOTICE
Use a charcoal element when replacing the cab air filter and cab recirculating air filter.
(A) Cab Recirculating Air Filter - P/N 420000001
(B) Cab Charcoal Air Filter - P/N 490003651
472000007

NOTICE
• Do not run product pump (A) dry. Seal damage will occur.
• Do not intentionally dead-head the pump with high pressure. Seal damage will occur.
472000035

NOTICE
BATTERY DISCONNECT PROCEDURE
• Wait 120 seconds to disconnect machine battery power post engine shut-down.
472000088

APACHE™

CHAPTER 3

OPERATION

Before performing any operation procedures, read the following safety messages and read the Safety Section.



WARNING! Control Hazard. DO NOT operate the Apache Sprayer while wearing a headset to listen to music or radio because it will be difficult to hear the warning signals.



WARNING! Impact Hazard. Secure any loose items in cab. Items that are unsecured may cause injury in case of a roll-over.



WARNING! Roll-Over Hazards

- **DO NOT operate on steep slopes.**
- **DO NOT drive across a slope. Drive up and down slopes.**
- **DO NOT turn down a slope.**
- **Slow down when turning.**
- **Keep booms as close to the ground as possible.**
- **Drive slowly across rough ground.**
- **DO NOT operate on public roads or highways with fluid in the product tank.**
- **ALWAYS use 4-way flashers on public roads or highways.**
- **ALWAYS come to a complete stop before reversing directions.**

Pre-Operation Checks

Before operating the Apache Sprayer, perform the following safety and equipment checks.

- Read and understand this manual before operating the Apache Sprayer.
- Read and follow all safety messages and safety decal instructions in this section. See "Safety" on page 2-1. Check the condition of all safety decals. Replace if damaged.
- Check that all shields and guards are properly installed and in good working condition. Replace if damaged.
- Check all hardware for proper installation and torque. See "Torque Value Charts" on page 6-1.
- Check the operating area for bystanders and obstruction before operating.
- Check that all hydraulic hoses and fittings are in good condition and not leaking. Make sure the hoses are routed to prevent damage, not twisted, sharply bent, kinked, frayed, or pulled tight or rubbing, before starting the Apache Sprayer. Replace any damaged hoses or fittings immediately.
- Check the operation and condition of the seat belt. Immediately repair or replace the seat belt if damaged or if it does not operate properly.
- Check tires for proper inflation pressure according to tire manufacturer's recommendations. Specifications are also provided on the back cover of this manual. See "Check Tire Pressure" on page 5-12.
- Check engine oil level and add oil as needed. See "Check Engine Oil Level" on page 5-12.
- Check transmission fluid level and add fluid as needed. See "Check Transmission Oil Level" on page 5-14.
- Check differential, gearboxes and/or planetaries fluid levels and add fluid as needed. See "Check Differential Fluid Level" on page 5-17.
- Check coolant level and add coolant as needed. See the engine manufacturer's manual for details.
- Check hydraulic reservoir fluid level and add fluid as needed. See "Check Hydraulic Fluid Level" on page 5-15.

Transporting and Trailering Apache Sprayer

The Apache Sprayer will come from the factory with locking bars installed between the frame and the front axle arms. The locking bars are designed to keep the axles in a level position in case the air suspension leaks down. They are located between the air bag and the shock absorber on either axle arm.

NOTICE: *Never operate the machine with the front axle locking bars installed. Serious damage to machine or the operator could occur.*

Removal of Front Axle Locking Bars

In order to remove the locking bar (1), pressure will need to be relieved by airing up/down the airbag. Push either the inflate (2) or deflate (3) button on the valve to relieve pressure on the bar.

Remove pins from top and bottom of bar and slide bar out.

Storage of Locking Bars

Locking bars can be stored on the frame when not in use. Locate the tabs underneath the top frame tube behind the front air suspension valves (1). The locking bars can be stored using the same pins used to lock the axle.

NOTE: Locking bars can be reinstalled for long periods of storage or transporting the sprayer. This will ensure tires are not put under excessive side load if air suspension leaks down. If locking bars are reinstalled for storage or transport, take care to remove them before operating the sprayer.

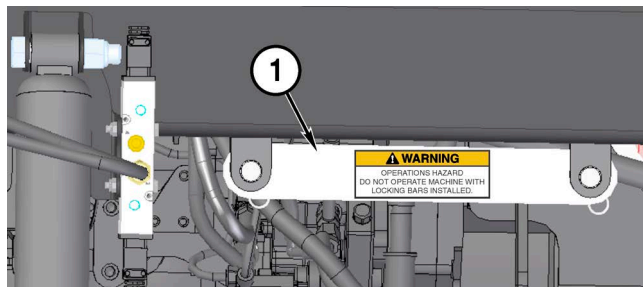
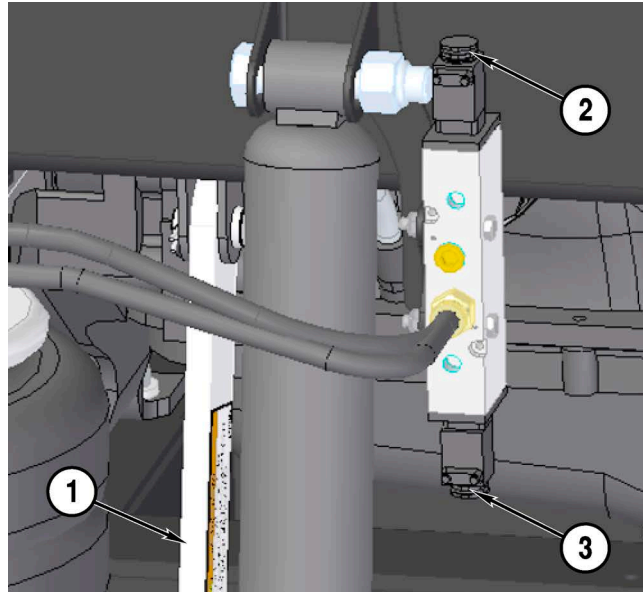

Cab Overview

1. **Air vents (not shown)**
(multiple points in the steering column)
2. **Steering Column**
3. **Steering Wheel**
4. **Joystick**
5. **ET Pilot System**
6. **Arm Rest**
7. **Brake Pedal**
8. **Air Seat**
9. **Fire Extinguisher (not shown)**
(left of the driver seat)

Cab Access Ladder

1. Access Ladder

The cab access ladder is automatically actuated by the parking brake switch.

- When the parking brake is applied, the ladder folds down.
- When the parking brake is released, the ladder folds up.



Steering Column

NOTE: DO NOT drill the plastic of the steering column, or alter in any way.

1. Steering Column Tilt Adjustment Lever

- Lift up on the lever.
- Adjust the tilt to the desired position.
- Release the foot lever to lock the column.

2. Steering Wheel

3. Steering Wheel Telescope Adjustment Knob

- Turn center knob counterclockwise to unlock.
- Position steering wheel to desired height.
- Turn center knob clockwise to lock.

4. Horn Button

Push to sound horn.

5. Turn Signal Lever

- Push lever up for right turn signal.
- Push lever down for left turn signal.

6. Windshield Washer

- Push ring to operate washer.

7. Windshield Wiper Switch

- Turn lever to the "I" position for low speed wiper.
- Turn lever to the "II" position for high-speed wiper.
- Turn lever to the "J" position for delay wiper.

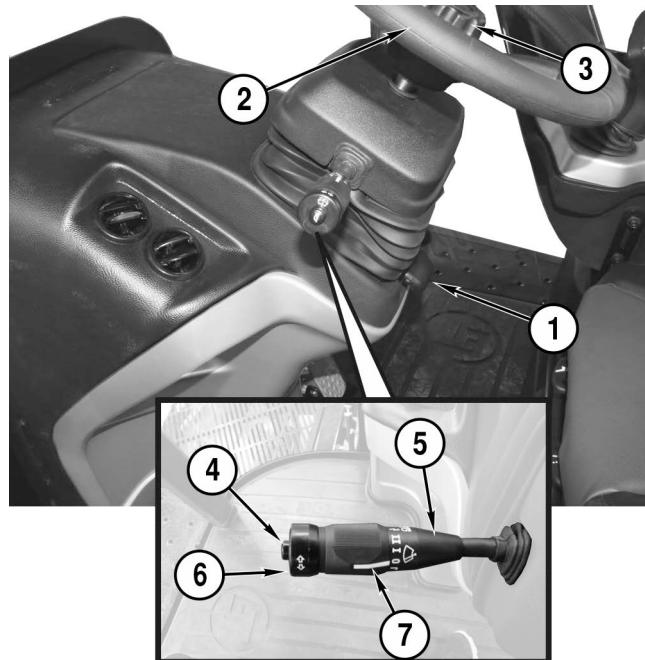

ET Pilot System

1. Fault Code Indicator
2. General Warning Indicator
3. High Exhaust Temperature Lamp
4. Exhaust System Cleaning in Progress
5. Exhaust Cleaning Disabled
6. High Beams Indicator
7. Cruise Control Indicator
8. Engine RPM and MPH Readout
9. Engine Coolant Temperature Gauge
10. Turn Signal Indicators
11. Scheduled Maintenance Icon
(Appears only when there is Scheduled Maintenance required.)
12. Update Available
13. Boom Rack Lock Icon
14. Engine Hours
15. Direction and Gear Indicator
(The gear indicator will remain solid when torque converter is locked in.)
16. DEF Gauge
17. Autofold Icon
18. Date and Time Indicator
19. Fuel Gauge
20. Cruise Control Buttons
21. Product Pump Switch Manual/Auto
22. Manual Product Pump PWM Increase/Decrease Buttons
23. Product Tank Agitation Increase/Decrease Buttons
24. Left Boom Tip Fold in/out Switch
25. Right Boom Tip Fold in/out Switch
26. Rack Lock Button
27. Rack Autolevel
28. Left Inner Boom Fold in/out Switch
29. Right Inner Boom Fold in/out Switch

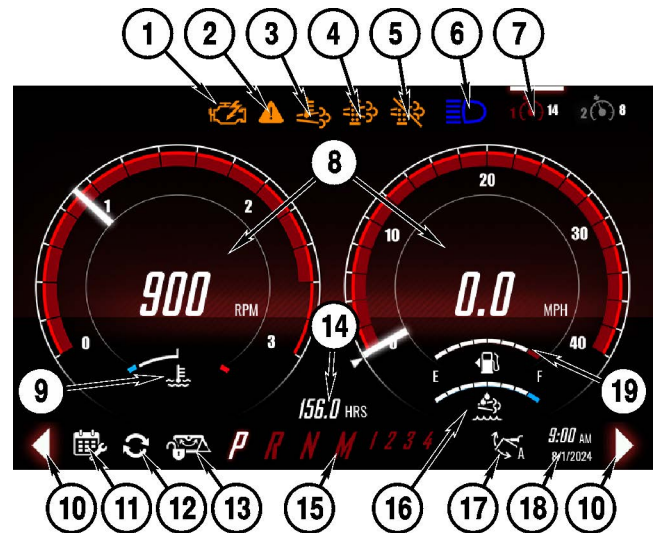

ET Pilot System Touch Screen

To use the screen there are a few things to know.

To change the items inside the gauges, touch the RPM or MPH icons (1) to display different options such as:

Average GPH, Torque, MPH and RPM.

To move to the App Screen, swipe left anywhere in the middle of the screen (2) except for inside the gauges (1). (3) is the Date and Time setting.

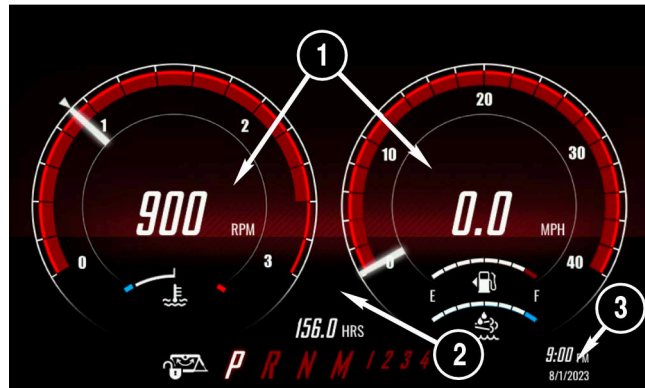

To change the date and time setting, tap the Date and Time indicated by (3) above.

This screen will appear. Use the plus and minus signs to change up or down. Use the Back and Next buttons to move among hours, minutes, date, etc. Cancel to return to the Home Screen.

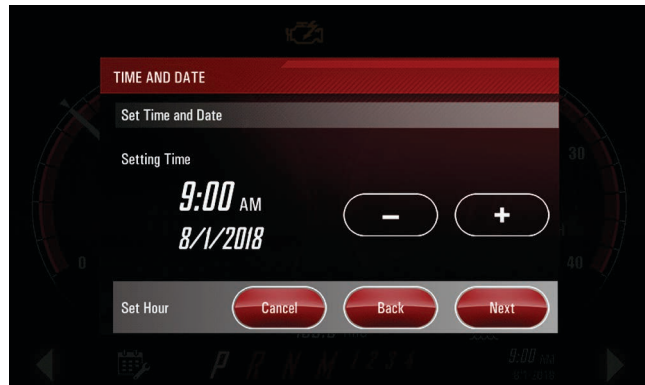

Adjust as needed, then click OK to Save your changes and return to Home Screen.

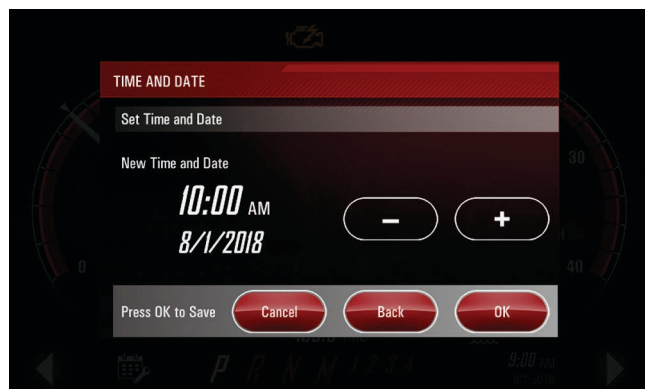

ET Pilot System Touch Screen (continued)

After moving to the App Screen (by swiping left, anywhere in the middle of the home screen, except for inside the gauges) select an App, by touching the desired icon (1) on the screen to move to the selected screen.

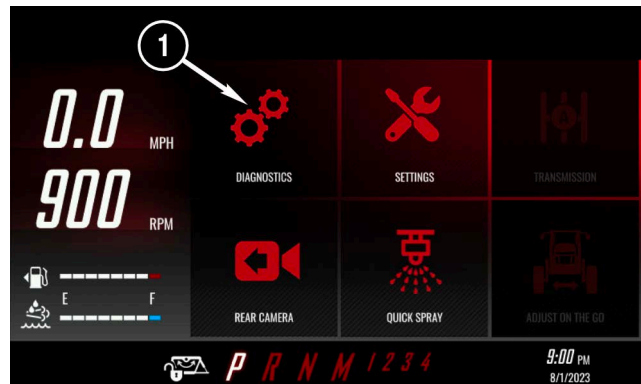

Once in an App screen, there are a few options to choose from. To return to the App Screen, swipe the header bar (1) to the right. To see what page you are within the App, look at the page indicator (2). To move from page to page, swipe left or right in the middle of the screen (3). To scroll the page, swipe the middle of the screen up or down (4).

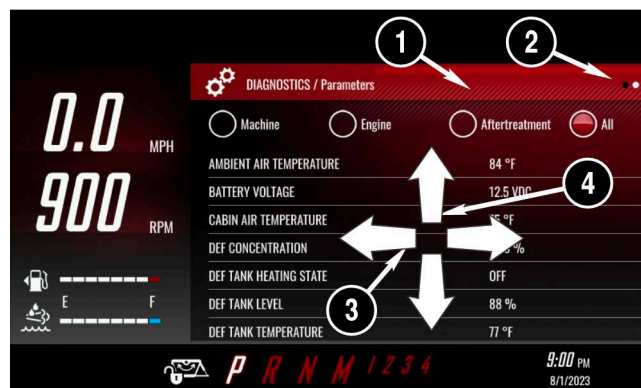

To return to the Home Screen, swipe the screen to right from the top or the left side (1). This will work on any of the screens.

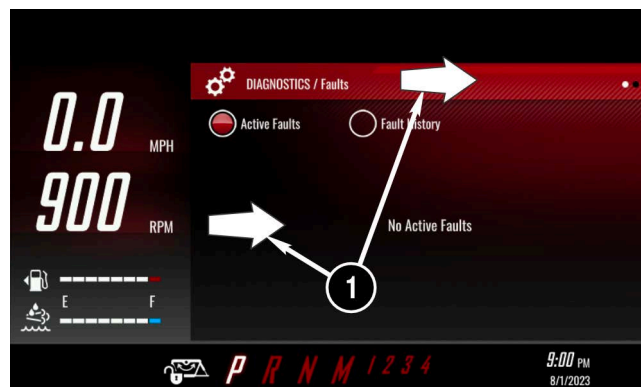

Diagnostics Page 1: Vehicle Warnings

When a new vehicle warning happens, the touchscreen will display a warning screen. It will indicate the fault code (1) and general description of that code (2). Touch the OK icon (3) to close the screen.

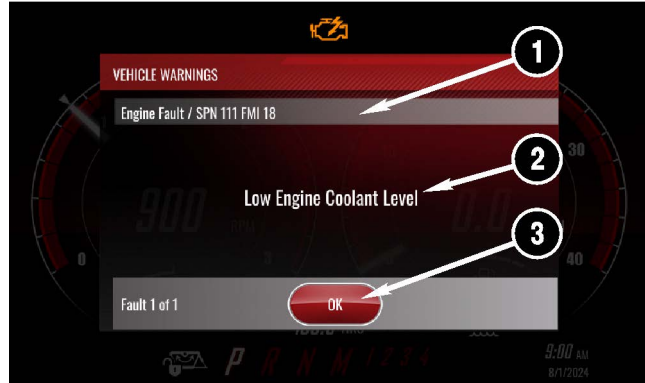

To access the Active Faults screen, either touch the fault indicator (1) at the top of the screen or touch the Diagnostics App icon (2).

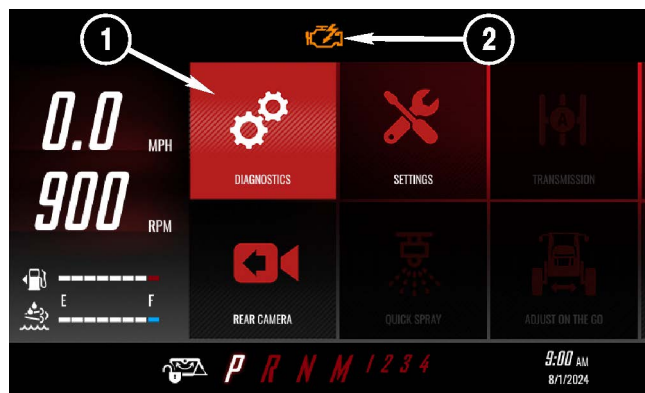

Active Faults

This page will display the option to choose active faults or fault history. Choose active faults. Then touch the fault information bar (1) to expand for further detail.

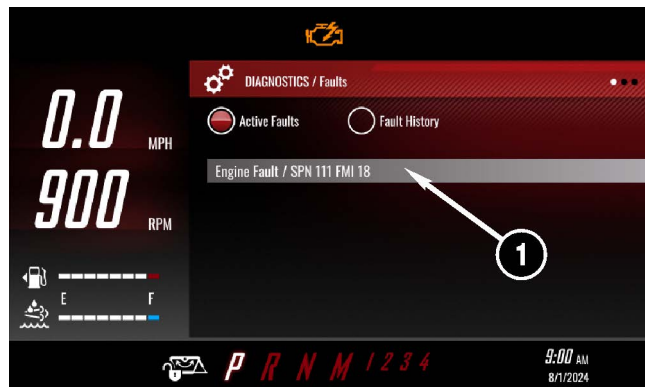

Once the information has expanded, the page will display more detail. This will include the Reason and Effect (1) on the machine.

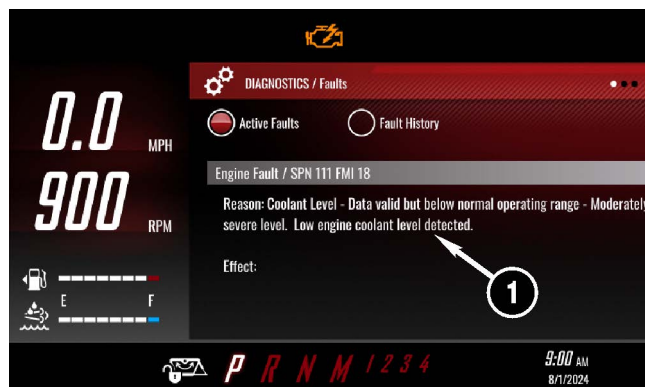

Fault History

This page will display the option to choose active faults or fault history. Choose fault history (1). Then touch the fault information bar to expand for further detail (2).

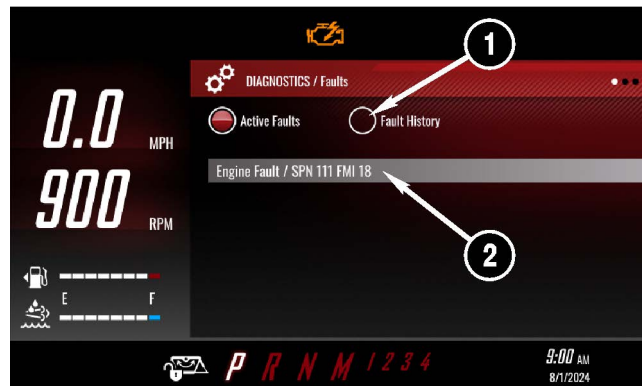

Once the information has expanded, the page will display more detail. This will include the Reason and Effect (1) on the machine. The last hours are shown when the fault was last active (2).

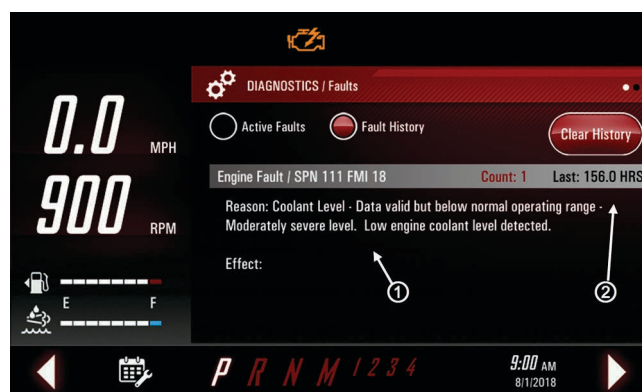

Clear Fault History

Press the Clear History (1) button to clear all saved history.

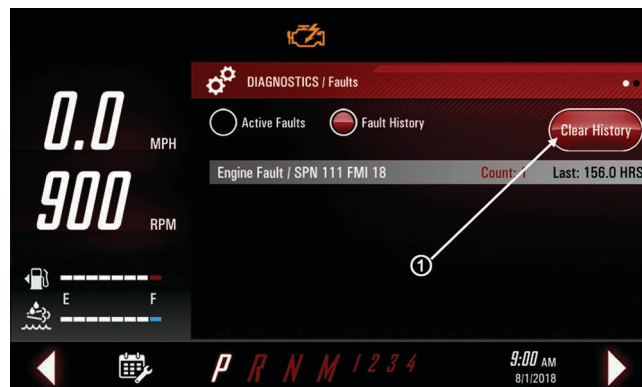

It will then display a prompt (1) to confirm whether or not you would like to clear the history. Select Yes to confirm Clear Fault History.

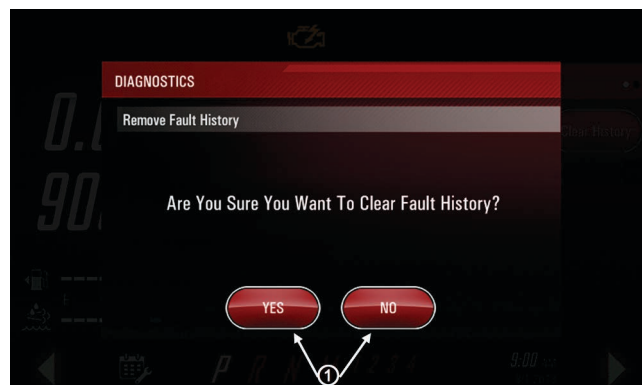

Diagnostics Page 2: Parameters

To filter for Machine Parameters only, select Machine button. To filter for Engine Parameters only, select Engine button. To view All Parameters select All (1). To view all the information on that page, swipe the screen up.

Some of the information included on page 2:

- Battery Voltage
- DEF Concentration
- DEF Tank Heating State
- DEF Tank Level
- DEF Tank Temperature
- Diesel Fuel Tank Level
- DOC Inlet Temperature

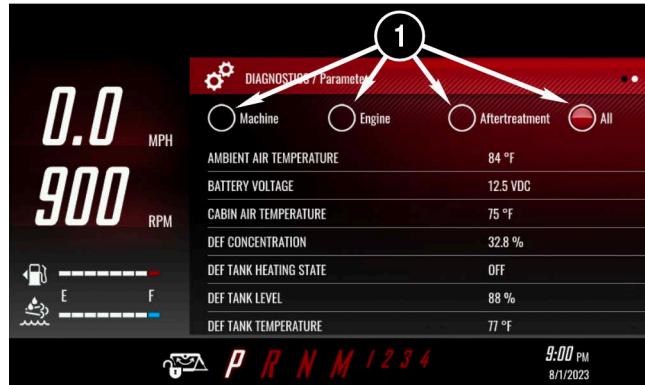

Scheduled Maintenance App

The scheduled maintenance app is used to provide maintenance information and reminders. The app icon is located on the second page of the app menu. (1) This app can also be opened via a maintenance reminder icon on the bottom row (2).



General Maintenance App Page

The first page of the General Maintenance app is a table showing general maintenance items and recommended schedule.

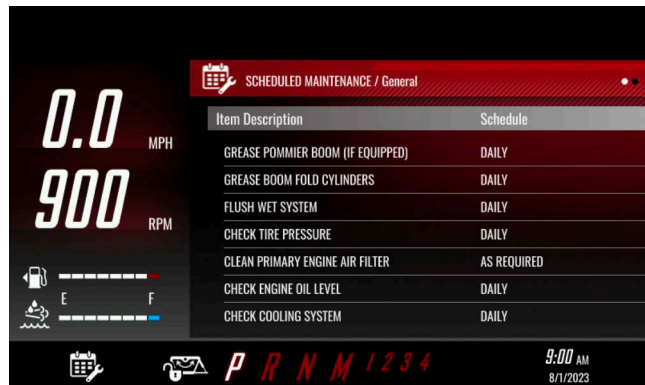

Interval Maintenance App Page

The second page of the app is a list of key maintenance items that run on engine hour based intervals. The lists shows the description, last time performed, and the next required maintenance. The last time performed is initially populated with “N/A”, then the next time required is calculated assuming that maintenance was performed on schedule up and to the current engine hours.

Maintenance Entry

Alongside each item on the interval maintenance page is a button that allows the user to enter a maintenance event for that item (1).

Selecting the entry button opens a dialog that asks the user if they would like to add a maintenance entry for that item description. Selecting OK opens the screen shown on right as (2). This shows the current engine hours as well as up and down arrows. Click OK to indicate maintenance performed. (or change hours to if needed, then select OK.) Selecting Cancel closes the window and exits to the app page.

Maintenance Reminders

When required maintenance is within 10 hours of the current engine hours, a maintenance icon is shown (1). Pressing the icon takes you directly to the interval maintenance app page.

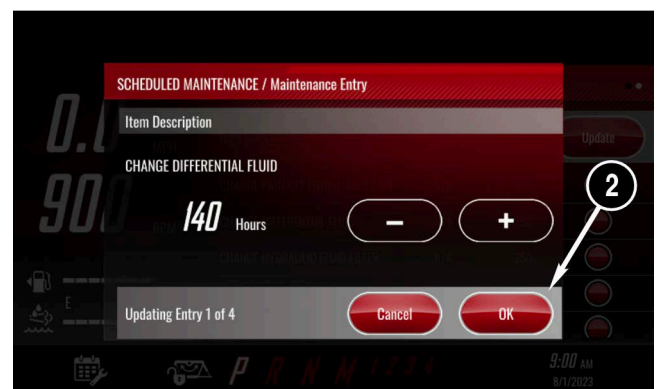
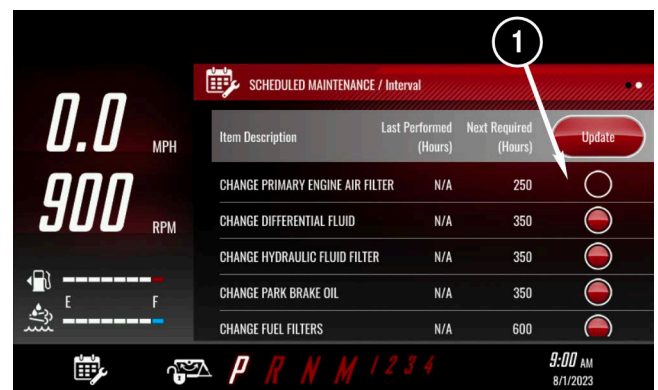
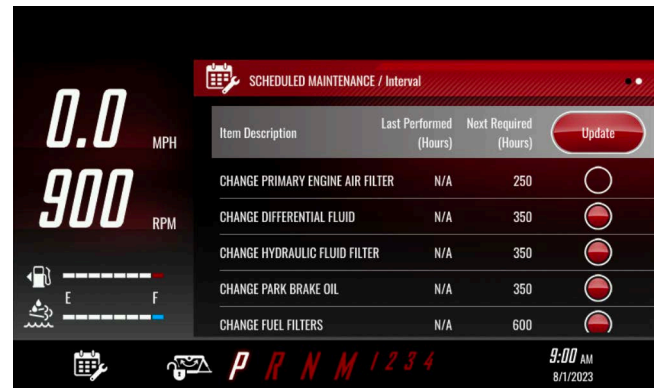

A maintenance reminder pop up is shown whenever there are scheduled items.

- You must press OK to clear the screen.

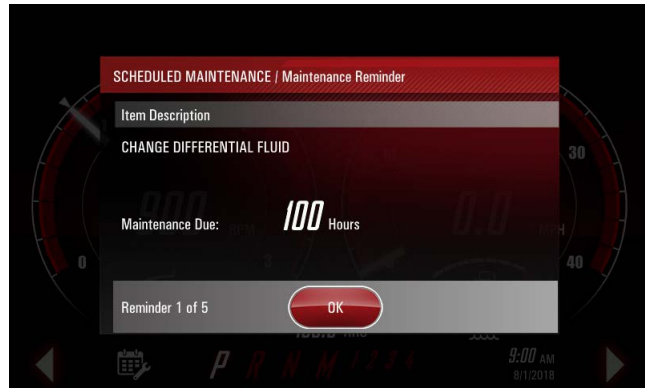

Vehicle Settings Page 1:

To activate these settings, touch the white circle (1). This will allow you to make adjustments to those settings by using the slider (2). Touch the red icon in the slider and swipe left or right to increase or decrease the value. To access the remaining options on this page, swipe the screen up (3).

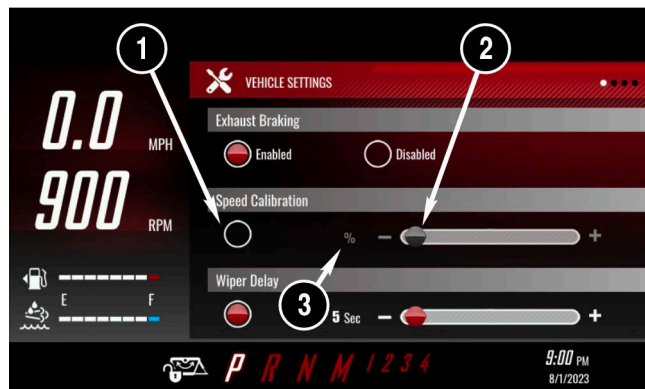

The same applies for this screen. Touch the white circle (1) to activate and use the slider (2) to change the values. To continue to the next Vehicle Settings page, swipe the screen (3) to the left.

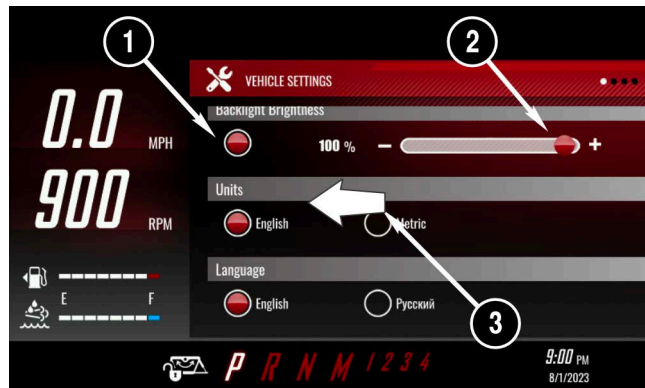

Vehicle Settings Page 2:Version Information

NOTE: To be able to continue to the next page, a passcode is needed. This is a warning that the changes that are going to be made, will effect the machine’s function.

Enter the code “2201” by touching the number icons (1). To cancel and return to the previous screen, touch the cancel icon (2). To delete a previous typed number, touch the backspace icon (3).

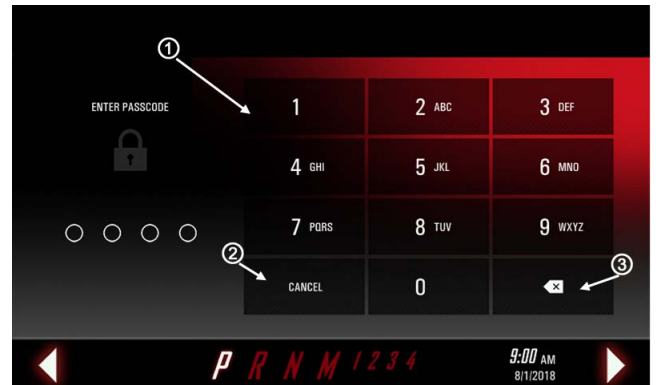

This screen will display the current version of the machines software. It will also display the new version if there is a machine software USB drive loaded.

Please consult with your dealership about any updates.

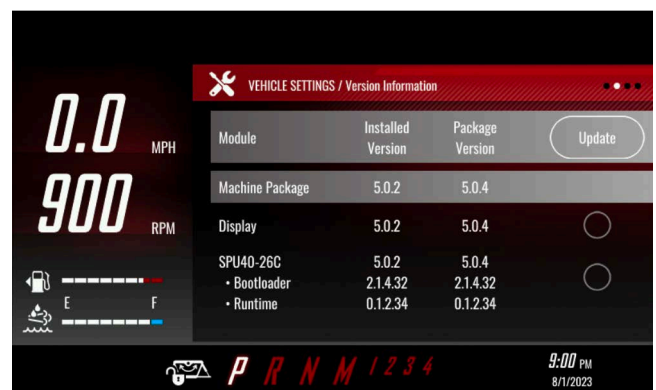

Vehicle Settings Page 3: Front Suspension (Airbag) Calibration

Step 1: To calibrate the front suspension, press Begin (1) on the screen and drive forward until the machine is fully lowered.

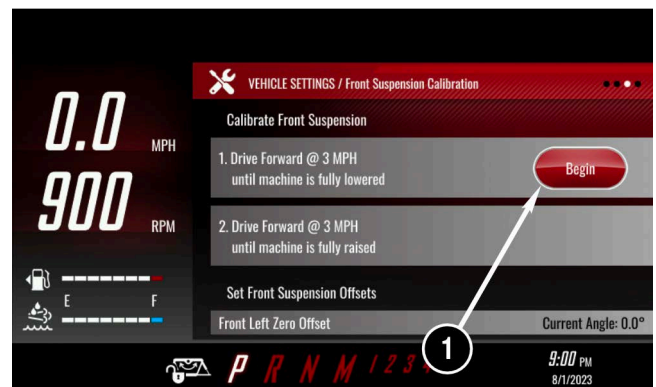

Then press Done (2).

Step 2: Repeat Step 1 and press Done (2) when the machine is fully raised.

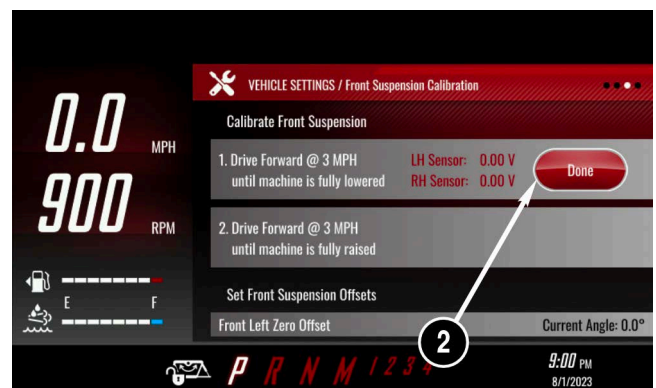

Vehicle Settings Page 3: Front Suspension (Airbag) Calibration (continued)

Step 3: If the axles are not even, adjust the right or left zero offset accordingly.

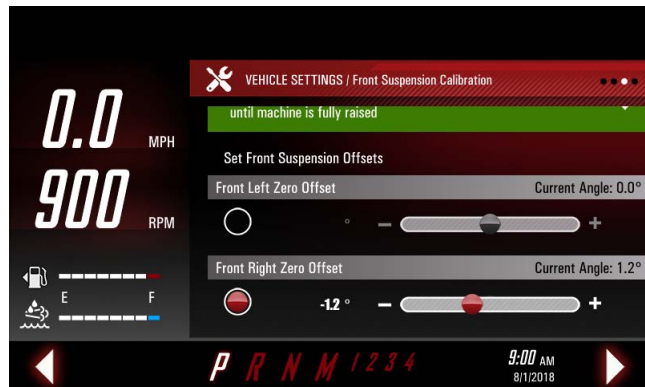
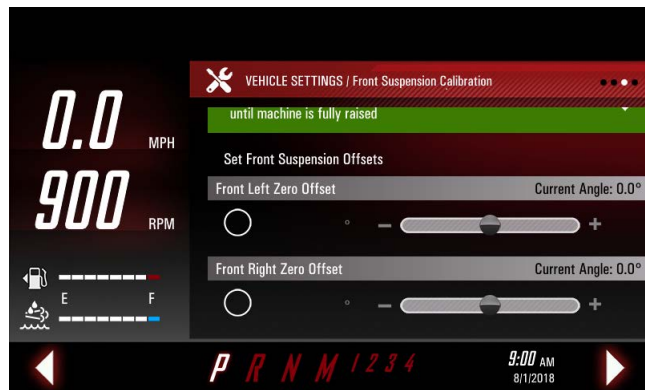
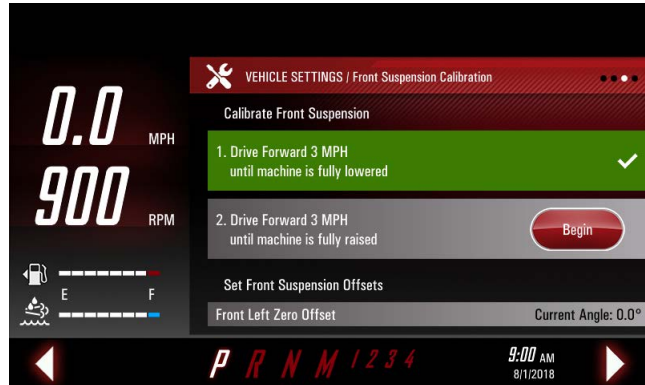

Vehicle Settings Page 4: ET AutoFold (If Equipped)

The ET Autofold feature calibration page allows the user to see the current status of all sensors as well as recalibrate the AutoFold feature. All fold sensors are listed along with their respective calibration, in range status and current voltage reading. This voltage reading is live and will change when the booms are moved.

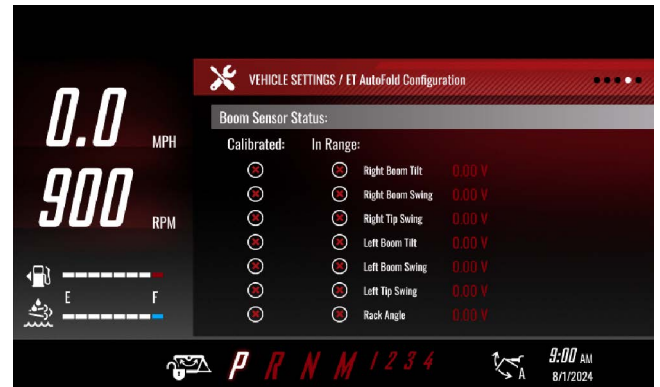

Calibrate AutoFold Feature

Swipe up to scroll to step 1, move the boom to the specified location and select “Write” (1).

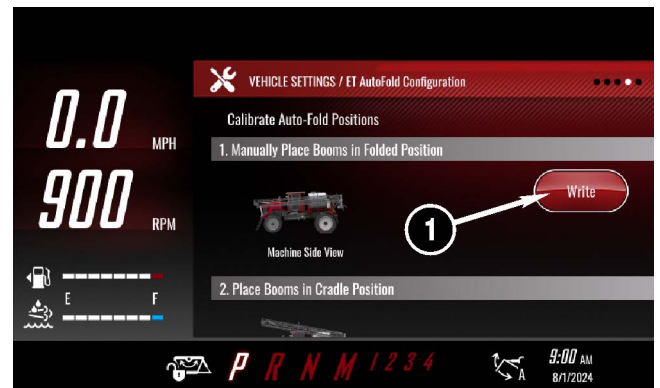

Select “Done” (2) to move to the next step.

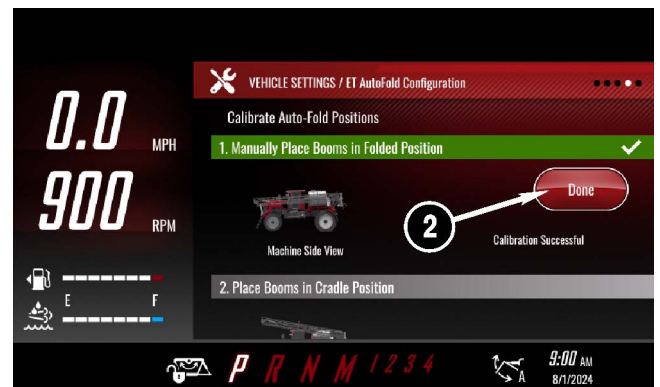

Swipe up to scroll to step 2, move the boom to the specified location and select “Write”. Continue this process until all 7 steps have been completed.

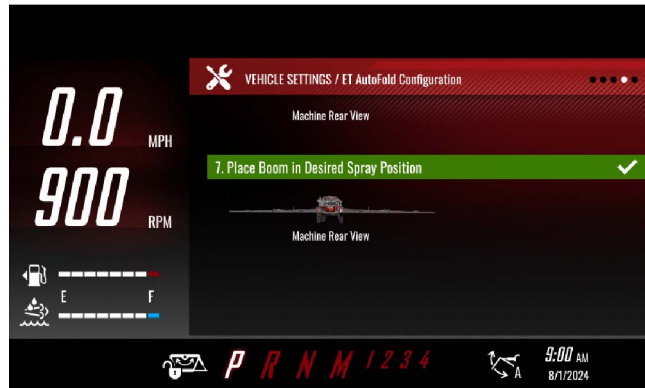

If all steps were calibrated and the sensor voltages in range, all indicator bubbles will be green (3) and the autofolding icon (4) will show at the bottom of the screen.

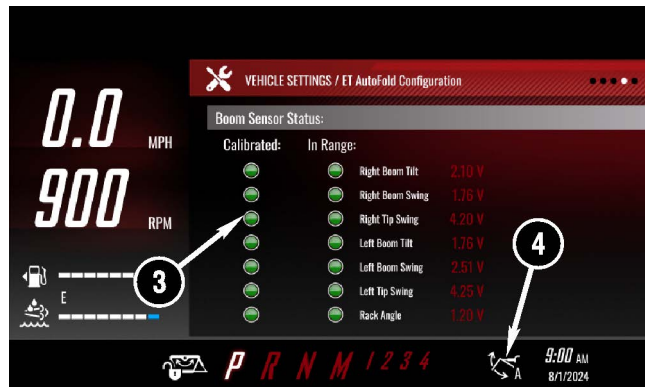

A red X in the “In Range” column (5) indicates the sensor voltage was either less than 500mV or greater than 4500mV which could indicate a:

- Faulty sensor
- Faulty electrical connection
- Faulty mechanical linkage.

Once the issue is addressed, the AutoFold feature can be recalibrated

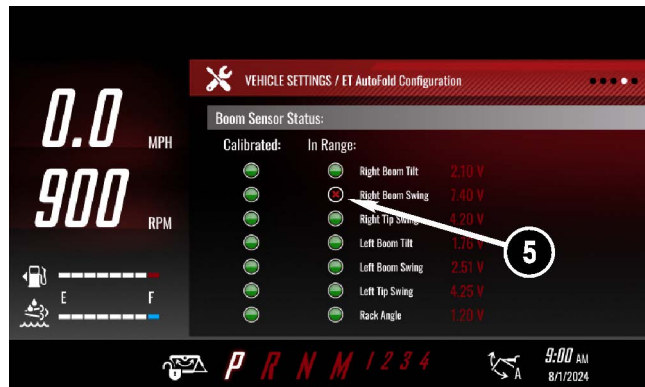

After calibration has been completed, the boom folded position as well as the boom spray position can be recalibrated at any time to adjust as needed. A sensor replacement or controller replacement will require a full recalibration of the AutoFold feature. The AutoFold feature can be completely recalibrated by starting with step 1 as stated above.

For more information on utilizing the AutoFold feature, See "AutoFold (If Equipped)" on page 4-12.

Vehicle Settings Page 5: Configuration

The selection for Machine Model is AS650 (1).

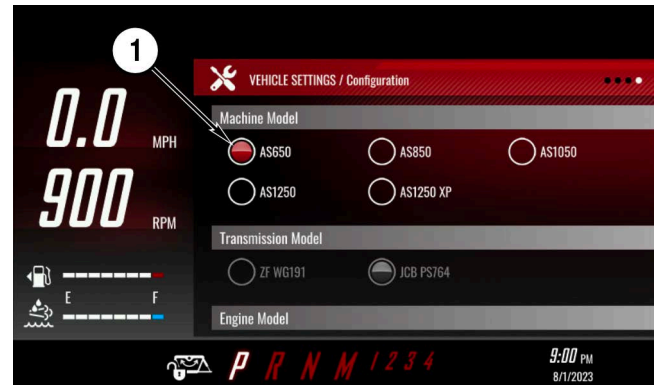

The selection for Transmission Model must be the JCB PS764 (2).

The selection for the Engine Model, must be Tier 4F (3).

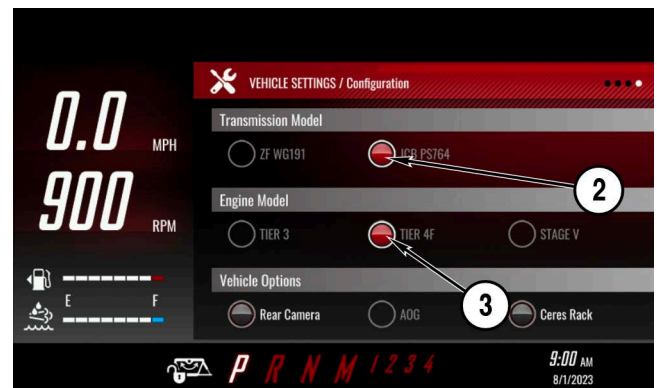

Scroll down to see all of the Vehicle Options (4). Only select the options equipped on the machine.

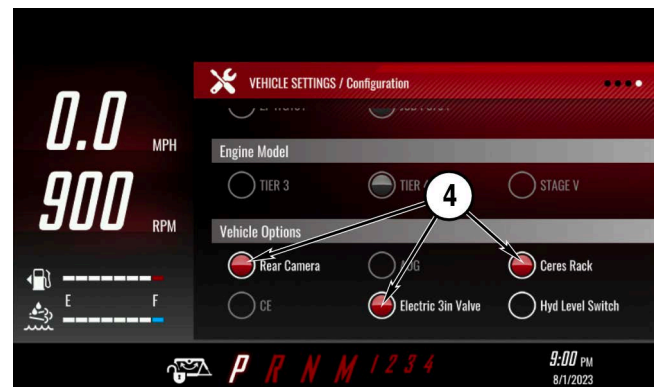

Light Switches

1. Driving Lights

- Flip the switch to turn on the hood-mounted head-lights, marker lights, and tail lights.
- Flip the switch again to turn off the lights.

2. Cab Front Work Lights

- Flip the switch to turn on the cab-mounted, front-facing work lights.
- Flip the switch again to turn off the lights.

3. Cab Rear Work Lights

- Flip the switch to turn on the cab-mounted, rear-facing work lights.
- Flip the switch again to turn off the lights.

4. Boom Lights

- Flip the switch to turn on the dual beam boom lights.
- Flip the switch again to turn off the lights.

5. Beacon Light and Hazard Lights

- Press the top of the switch to turn on the roof-mounted beacon light.
- Press again to turn off the light.
- Press the bottom of the switch to turn on the flashing hazard lights.
- Press again to turn off the lights.

6. Dome Light

- Press the button to turn the light on and off.

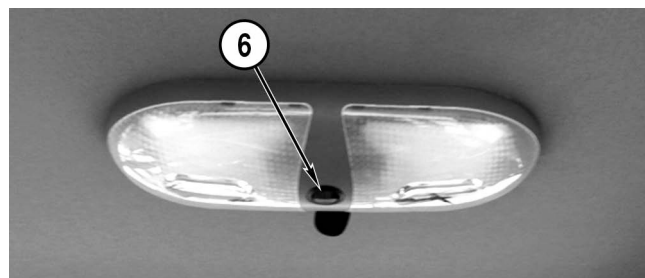
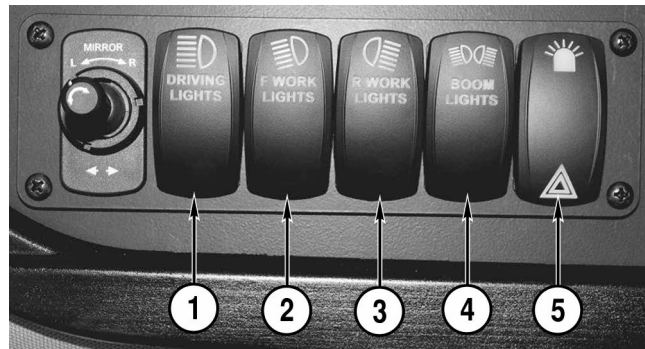

Apache Sprayer Lighting

1. Headlights

2. Cab Front Work Lights

3. Beacon Light

4. Cab Rear Work Lights

5. Dual Beam Boom Work Lights

6. Side hazard and Turn Signal Lights

7. Rear Hazard and Turn Signal Lights (Mounted to rear fenders - not shown)

8. Brake Lights (Mounted to rear fenders - not shown)

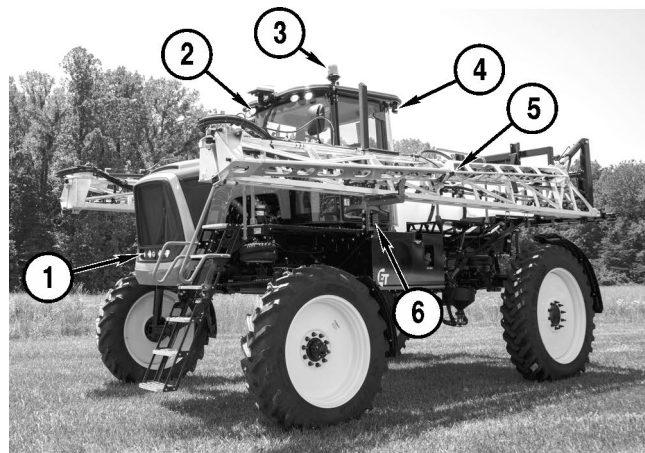

Turn Signal and Hazard Light Function:

- When the hazard lights are turned on, light sets #5, #7, and #8 will all flash.

Turn Signal Function:

- When the left turn signal is turned on, the left side of light sets #5, #7, and #8 will all flash.
- When the right turn signal is turned on, the right side of light sets #5, #7 and #8 will all flash.

If the hazard lights are already flashing when the turn signal is activated, the lights opposite the turn indicator will glow steady while the lights on the side of the turn will flash.

AM/FM Radio with Weather Band and Streaming Player

- AM/FM
- Bluetooth Streaming Audio
- NOAA Weatherband Tuner with Alerts

For detailed instructions visit the manufacturer’s website:
<http://asaelectronics.com/manuals-guides> -- search for model number JHD62.



Accessories

(Located behind the right-side arm rest on the back wall.)

1. **Lighter.**
2. **Accessory power.**

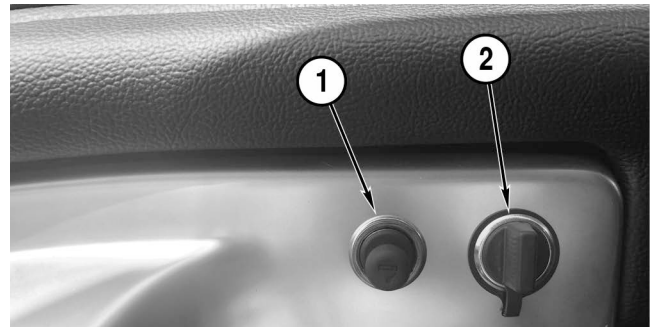

Seat Adjustment

Leather Seat

1. Slide Release Lever:

- Pull, hold and slide forward or rearward.
- Release to stop slide.

2. Fore-Aft Position of the Seat Cushion Only

- Pull up and hold to adjust, release to stop.

3. Seat Cushion Tilt:

- Pull up and hold to adjust, release to stop.

4. Ride Firmness:

- Turn the knob counter-clockwise for soft ride.
- Turn the knob clockwise for firm ride.

5. Fore-Aft Isolator:

- Turn the lever to the left to allow front-to-back movement of the seat.
- Return the lever to the right to lock-out movement.

6. Backrest:

- Lift the lever.
- Position the backrest.
- Release the lever.

7. Seat Belt

8. Height:

- Lift lever to raise the seat.
- Push the lever down to lower the seat.

9. High/Low/Off Button for Seat Cooling/Heat

- The top position is high, the center position is off, and the bottom position is low.

10. Activate Seat Heat/Cool Button:

- Select fan to activate cooling. Select seat with lines to activate heat.



Joystick and Universal Terminal Console

1. **Universal Terminal Console (option)**
2. **Joystick**
See "Apache Sprayer Direction and Speed" on page 3-24.
3. **Auto Steer Engage Button**
(If equipped)
4. **Master Spray Button**
5. **Boom Rack**
Press to move the boom rack up or down.
6. **Right Boom Tilt**
Press to tilt the right boom up or down
7. **Left Boom Tilt**
Press to tilt the left boom up or down.
8. **Transmission Upshift Trigger Button**
(back of joystick - not shown)
9. **Transmission Downshift Trigger Button**
(back of joystick - not shown)

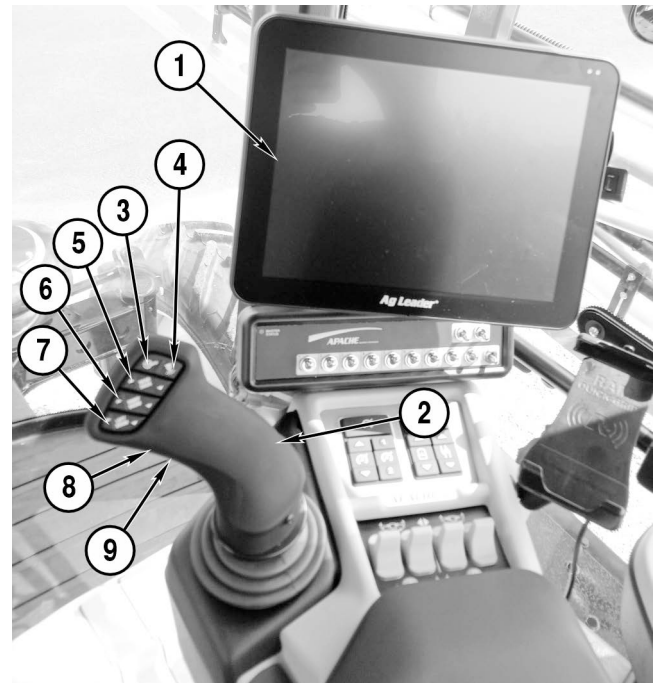

Interior Decal Location

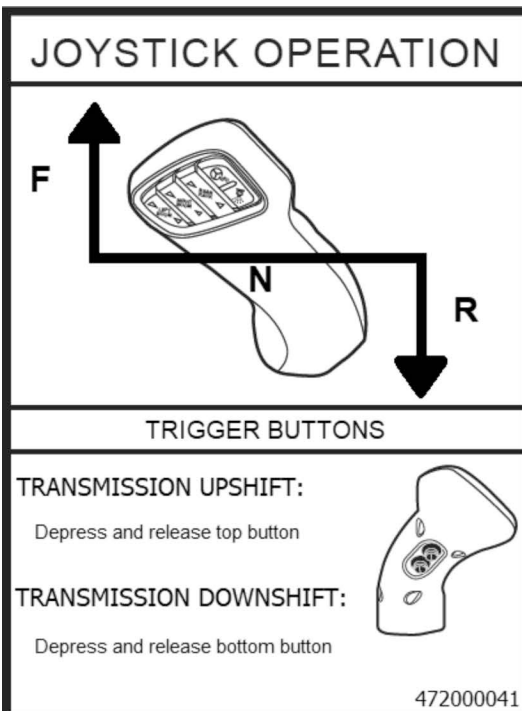

Starting and Stopping the Engine



WARNING! Impact Hazard. ALWAYS fasten your seat belt when operating the Apache Sprayer. The safety belt must be worn properly by the driver anytime the Apache Sprayer is in motion. See "Safety Belt" on page 2-4.



WARNING! Sudden Movement Hazards. ALWAYS start the engine from the operator's seat. ALWAYS set the parking brake (1) before starting the engine. ALWAYS fasten your seat belt before starting the engine.



WARNING! Fire Hazard. NEVER start the engine by shorting across the starter terminals.

Starting

1. Press and hold the Start/Stop Button (1) to crank the engine.
2. When the engine starts, release the Start/Stop button.

******Safety feature: Must depress the brakes to put into gear the first time.**



NOTICE: NEVER continuously crank the starter more than 30 seconds. Stop cranking and allow the starter to cool for 2 minutes between cranking to avoid damaging the starter.

NOTICE: If the engine stalls under load, immediately stop the Apache Sprayer and shift the transmission into NEUTRAL. Restart the engine immediately to avoid damaging the turbocharger.

- If the engine does not start after four attempts, see the Troubleshooting section in the engine manufacturer's service manual or contact your dealer.
- After the engine is started, check all gauges for normal engine operation. If the gauges indicate a problem, stop the engine and determine the cause.

Warm-up

Check the engine oil pressure gauge (1) as soon as the engine starts. To do this, access the App Screen and choose the Diagnostics

- If the oil pressure reading does not reach the minimum pressure of 15 psi [103.4 kPa], stop the engine and determine the cause.
- Normal engine oil pressure is 50 psi [344.7 kPa] when the engine oil is 240°F [116°C].

NOTE: Engine oil pressure can vary depending on conditions. See the engine manufacturer's service manual, supplied with the Apache Sprayer.

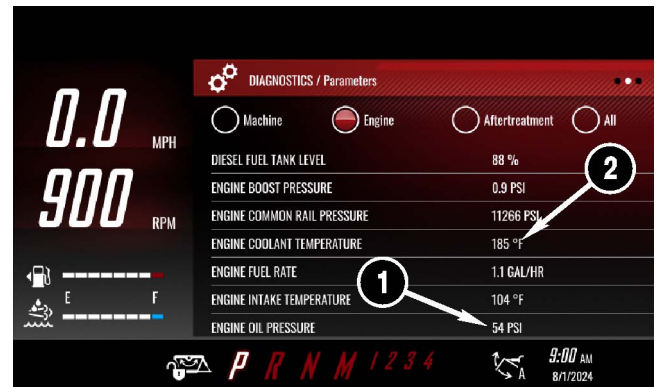

Check the engine coolant temperature (2), which is located on the same Diagnostics screen.

- Normal operating temperature is 180°F [82°C].
- If the engine coolant rises above 234°F [112°C], reduce the load on the engine.
- If the coolant temperature does not drop, stop the engine and determine the cause.

Stopping

NOTICE: After operating the engine under load, allow the engine to idle for 2 minutes before stopping to avoid damaging the turbocharger.

To stop the Apache Sprayer:

- Lower the engine rpm.
- Bring the Apache Sprayer to a complete stop.
- Shift the transmission to NEUTRAL by moving the joystick to the center position.
- Apply the parking brake (2).
- Press the engine Start/Stop button (3) to shutoff the machine.
- Be sure to disconnect the battery using the battery disconnect switch under the hood (4).

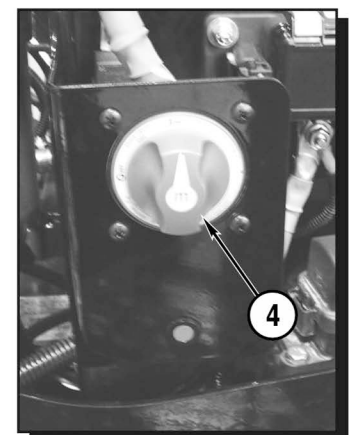
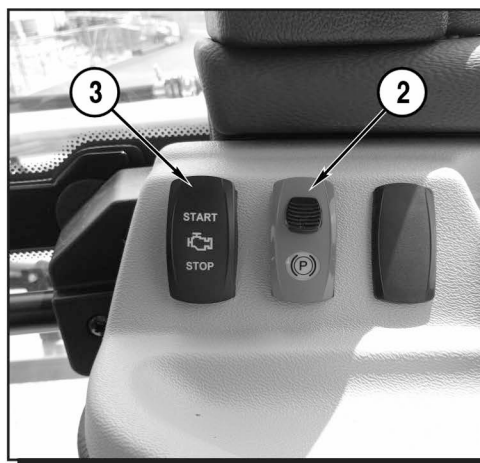
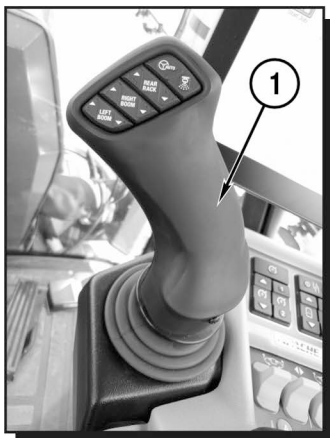

Apache Sprayer Direction and Speed



WARNING! Sudden Movement Hazards

- **NEVER** leave the operator's seat or cab when the Apache Sprayer is in gear. **ALWAYS** stop the Apache Sprayer, shift the transmission into **NEUTRAL** and then apply the parking brake before exiting the cab.
- **ALWAYS** stop the Apache Sprayer and apply the parking brake before changing direction. The Apache Sprayer must be at a complete stop before shifting the transmission into or from **FORWARD, REVERSE OR NEUTRAL**.

NOTICE: NEVER shift the transmission into **NEUTRAL** when the Apache Sprayer is moving. The transmission is only lubricated when in gear. Coasting will damage the transmission.

Neutral

At start-up, the Apache Sprayer transmission is reset to **NEUTRAL** and will be indicated at the bottom of the touch screen (1).

****Safety feature: Must depress the brakes to put into gear the first time.

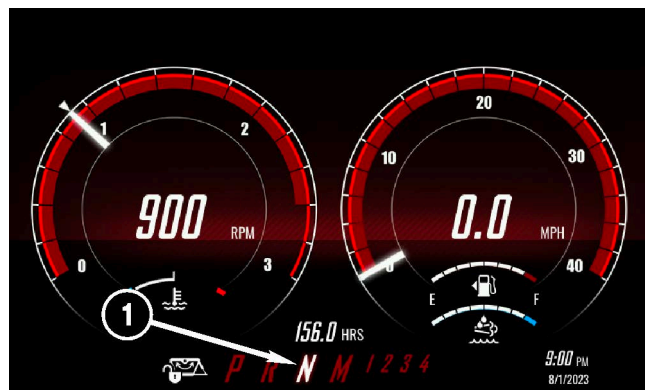

Move the joystick to the left or right to put into gear.

- Move the joystick to the left for **FORWARD** and to the right for **REVERSE**.
- Once the transmission is in gear, the gear indicator will show the current gear.

Return to **NEUTRAL** by moving the joystick to the center position.

- The transmission will immediately shift to **NEUTRAL**.

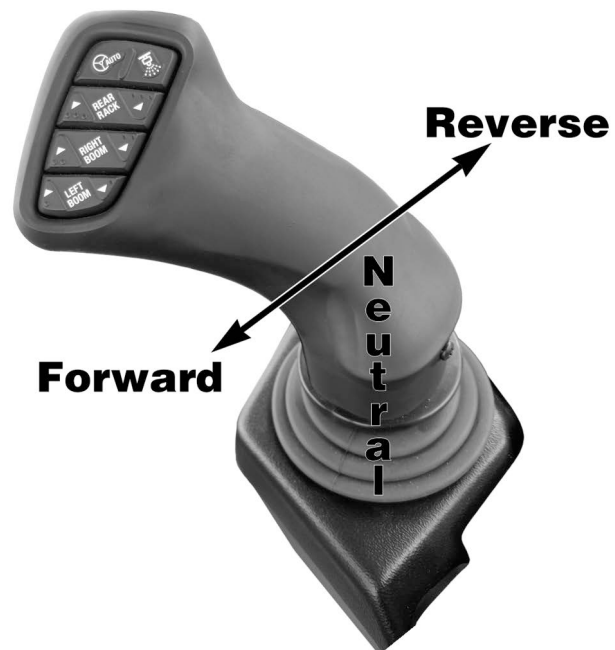

Forward

To move the Apache Sprayer forward:

Apply the foot brakes and release the parking brake.

NOTE: The transmission will not shift if the parking brake is applied.

To move forward:

- Release the park brake.
- Apply the Apache Sprayer brakes.
- Move the joystick to the left to shift into FORWARD. The machine will begin rolling forward at this time.
- Push the joystick forward to increase the engine rpm and ground speed.
- Pull the joystick back to decrease the engine rpm.

NOTE: Move the joystick to the center position to obtain NEUTRAL from a FORWARD gear.

NOTE: The Apache Sprayer will not shift into or out of NEUTRAL until the engine rpms are within an appropriate speed range.

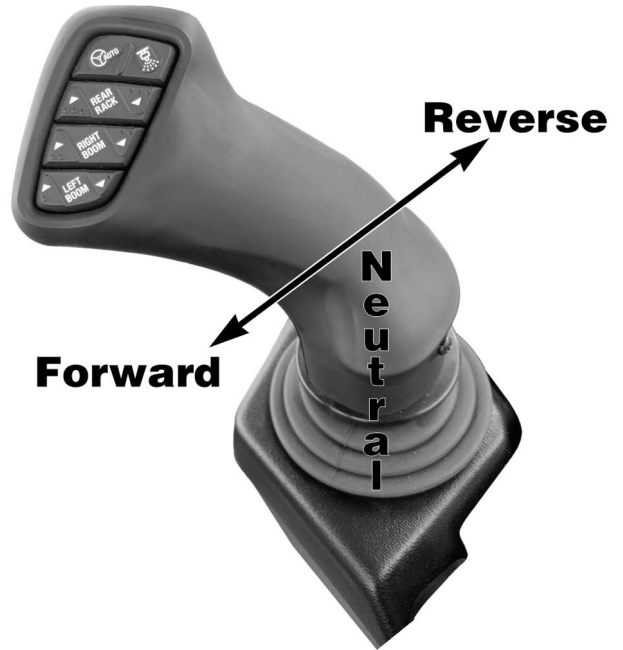

Shifting Forward Gears

The Apache Sprayer is equipped with a torque converter. This allows the Apache Sprayer to take off in any gear. Once the Apache Sprayer is moving, you may up shift or down shift without returning the transmission to the neutral position. The Apache Sprayer is equipped with four forward gears. Be aware of speed ranges for each gear. Use the Gear Speed Ranges chart for reference.

Gear Speed Ranges	
Gear	Speed
1st	0 to 5 mph [8.04 km/h]
2nd	0 to 9 mph [14.5 km/h]
3rd	0 to 16 mph [25.7 km/h]
4th	0 to 28 mph [45 km/h]

Upshifting and downshifting are achieved by pressing the trigger buttons on the backside of the joystick. Some time must be allowed for the transmission to respond.

Upshifting:

- While the Apache Sprayer is in either the FORWARD or REVERSE direction, press the top trigger button on the back of the joystick one time to shift up to the next higher gear. Repeat this motion to upshift the transmission one gear at a time.

Downshifting:

- Move the joystick slightly toward the center position to decrease engine rpm, lightly apply the Apache Sprayer brakes, then press the bottom button on the back of the joystick one time to downshift to the next lower gear. Repeat this motion to downshift the transmission one gear at a time.

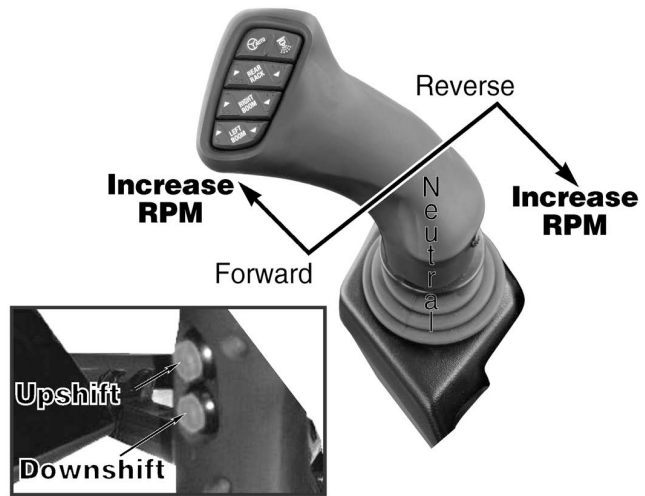

NOTE: The transmission is equipped with shift protect; the transmission will not downshift, even if the display read-out changes on the console, until the engine rpms drop down to the appropriate speed range.

NOTICE: NEVER shift the transmission into NEUTRAL while the Apache Sprayer is in motion. The transmission is only lubricated while in gear. Coasting will cause damage to the transmission.

Reverse

To move the Apache Sprayer in REVERSE:

NOTE: The transmission will not shift if the parking brake is applied.

- Apply the foot brakes.
- Release the parking brake.

To shift into REVERSE from NEUTRAL, move the joystick to the right of the center position.

- Pull the joystick back to increase the engine rpm and ground speed.
- Push the joystick forward to decrease the engine rpm.

To shift into NEUTRAL from REVERSE, move joystick up and over slowly to the center position.

NOTE: The Apache Sprayer will not shift into or out of NEUTRAL until the engine rpms are within an appropriate speed range

Exhaust Braking

Exhaust braking is a method which causes negative torque applied from the engine, which causes the drive-train to slow. The engine will initiate exhaust braking when the vehicle indicates that engine brake is enabled (1), throttle is at idle, and an engine overspeed is detected. All conditions must be met before it will be activated.

To enable exhaust braking, navigate to the first page of the Vehicle Settings screen and locate the Exhaust Braking section. Click the Enabled radial button (1) to activate.

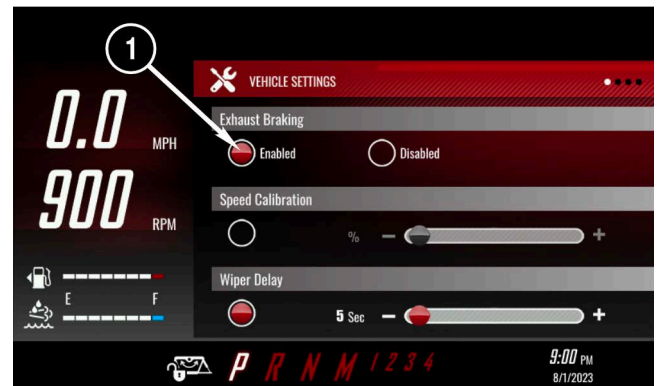

Cruise Control

The Apache AS650 offers the ability to set two cruise control points. To use the cruise control function, the machine must be in gear to operate. Using the cruise master switch, press either the Speed 1 or Speed 2 (1) to enable. To adjust the set speed, press the up/down arrow switch (2). It will adjust in one mile per hour increments. Once the speed points are set, they will remain at those positions until they have been readjusted. To achieve the cruise control setting, the joystick must be pushed fully forward. If the joystick is only halfway forward, the speed will only be half of the set speed. The cruise control will only operate between 6 and 20 mph.

Cruise control will disengage when:

- Brake is being pressed (will re-engage when the brakes are released)
- Master Cruise switch (1) is centered (off position).

To resume the cruise control: select the desired set point, one or two on the control pad.

When cruise control has been disengaged, speed and throttle will become manual, once the joystick is pulled back to match the engine rpm. The rpm/throttle position will go to the increment in which the joystick is positioned.

When the speed point icons (1) are visible, this indicates that the cruise master has been enabled. It will also indicate the set speed points for cruise one and two. There will be a white bar (2) located over the speed point icons when the cruise control is engaged. There are also two additional indicators (3) located around the speedometer.



Towing

ALWAYS use towing safety equipment and proper emergency warning lighting when towing the Apache Sprayer. If the Apache Sprayer's transmission should become disabled, it may be towed for approximately 1 mile [1.6 km] at speeds less than 3 mph [4.8 km/h]. While towing the Apache Sprayer, the engine should be running at idle and the parking brake released.

If the Apache Sprayer should become disabled and the engine will not start, remove the driveshaft between the differential and transmission. The Apache Sprayer may be towed up to 1 mile [1.6 km] at speeds less than 3 mph [4.8 km/h].

NOTICE: *The brakes depend on supply oil from the hydraulic system. If the engine is not running, you will have no brakes.*

NOTICE: *The brakes are located in the rear differential housing. If the driveshafts from the rear differential to the planetaries or drop boxes are removed, you will have no brakes.*

NOTICE: *DO NOT tow the Apache Sprayer if the:*

- Driveshaft is connected and it has no hydraulic supply to release parking brake.
- Rear differential is damaged (contact dealer for repair).

NOTICE: *DO NOT use the Apache Sprayer as a tow vehicle.*

NOTICE: *DO NOT use any part of the Apache Sprayer as a tow bar which is not designed for use as a tow bar or tow hook-up.*

Hood Tilt Latch

To raise the hood, pull the latch (1) at the top of the hood (near the cab) while pushing the hood forward.

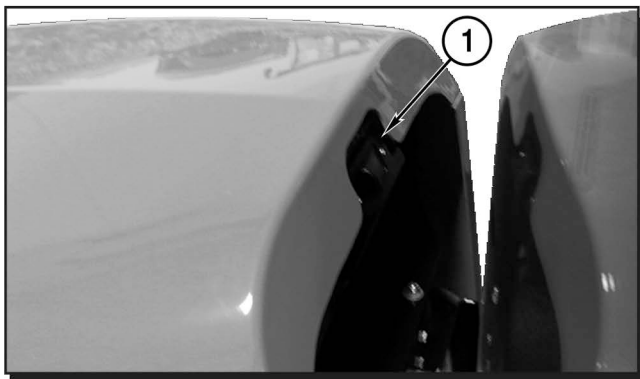

Battery

The batteries are located under the hood, between the engine and the cab.

The Apache Sprayer features a battery disconnect button, located next to the batteries. Turn counter-clockwise 1/4 of a turn to disconnect.

Turn the battery disconnect button off when working on the machine, finished with the sprayer for the day, and/or when storing.

NOTE: The negative battery cable must still be disconnected when servicing the machine.

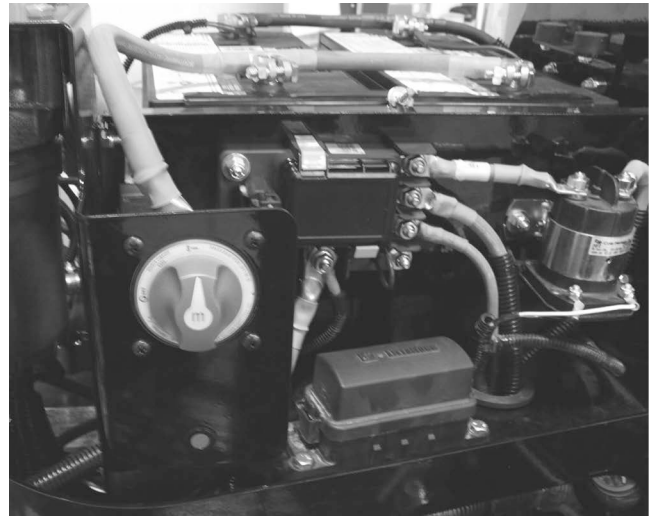

Climate Controls

1. Manual Fan Control Knob.

- Controls fan speed.

2. A/C Activation Knob.

- Turns A/C on.

3. Temperature Control.

- Select desired amount of heat/cold.

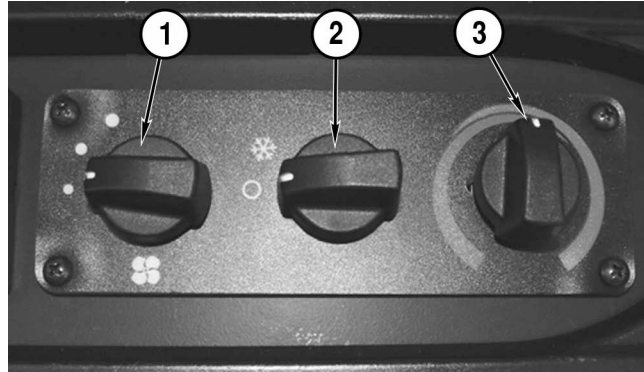

Precision Equipment

The following are factory installed precision sprayer control options:

- Raven Viper® 4+ (field computer)
- Raven RS1™ (GPS w/ autosteer)
- Raven AutoBoom™ XRT (boom height control)
- Raven AccuBoom™ (section spray control)
- Raven Boom Recirculation™ (plumbing cleaning system and waste reduction)
- John Deere® AutoTrac™ (integrated autosteer)
- CapstanAg® PinPoint® III (nozzle control system)
- Ag Leader® InCommand (field computer)
- Ag Leader® SteerCommand Z2 (autosteer)
- Ag Leader® DirectCommand L2 (section spray control)
- Ag Leader® RightSpot (nozzle control system)
- Ag Leader® BoomLoop (plumbing cleaning system and waste reduction)
- Norac UC7™ (boom height control)

Refer to the respective operators manual included with the machine before use.

NOTE: Raven-based precision equipment is designed in a joint effort with Equipment Technologies and Raven and contains items that are specific to Apache Sprayers. Please note this with your service provider when seeking service.

If your Apache Sprayer is equipped with anything other than factory installed precision equipment, please contact your dealer for assistance.

Antenna Mounting Plate

On machines equipped with GPS, a steel plate is mounted at the roof line at the front, center of the cab for magnetic base GPS antennas.



Rear Camera

If the rear camera is enabled, the full screen image will display when the sprayer is in reverse.

To manually access the camera, press the Rear Camera App icon (1).



The rear camera will display as well as the left information panel, regardless which direction the sprayer is moving. The camera will remain on the screen until a different function is chosen.

To access the Settings screen, slide the screen to the left.

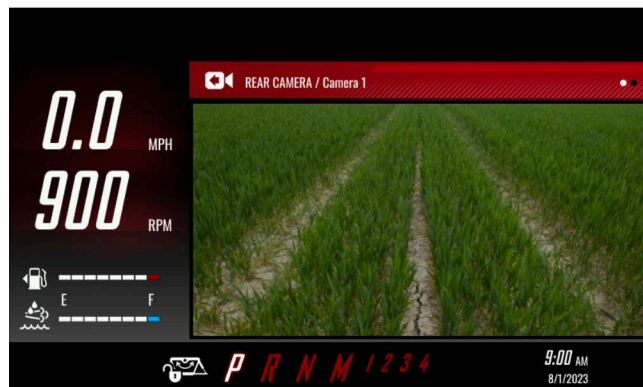
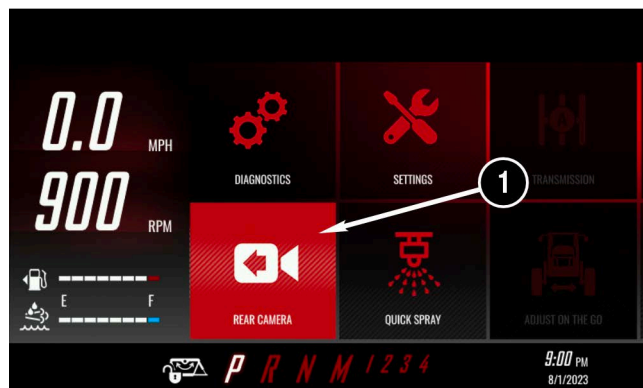

The Rear Camera Settings screen allows the operator to turn On and Off the Automatic Reverse Camera (1). Also, the image can be reversed by turning On the Mirrored Camera button (2).

If additional cameras are installed, they may be enabled in the Camera 2 and Camera 3 settings.

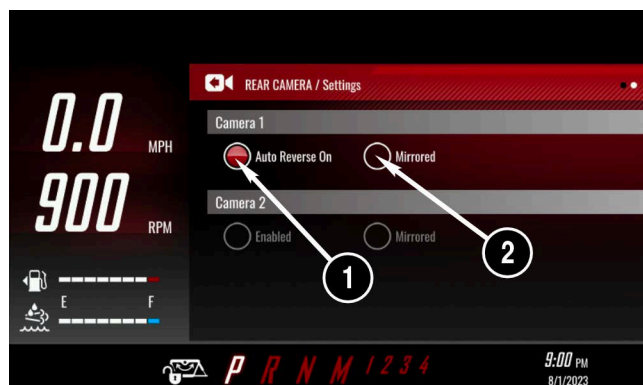

Jump-starting the Engine

Before performing any operation procedures, read the following safety messages and read the Safety Section.



WARNING! Fire Hazard. NEVER start the engine by SHORTING ACROSS the starter terminals.



WARNING! Impact Hazard. ALWAYS fasten your seat belt when operating the Apache Sprayer. The safety belt must be worn properly by the driver anytime the Apache Sprayer is in motion.

See "Safety Belt" on page 2-4.



WARNING! Sudden Movement Hazards

- ALWAYS start the engine from the operator's seat.
- ALWAYS set the parking brake before starting the engine.
- ALWAYS fasten your seat belt before starting the engine.

ET recommends jump-starting the engine through the starter terminals, using a Booster Battery.

- The Starter is located on the engine's right-hand side and can be accessed within the front, right wheel well.
- Connect one jumper cable to the positive (+) terminal on the booster battery. Connect the other end to the starter's positive terminal (+).
- Connect the second jumper cable to the negative (-) terminal on the booster battery. Connect the other end to the starter's negative terminal (-).
- Connect the battery via the battery disconnect switch.
- Set the parking brake.
- Engage the ignition.



NOTICE: NEVER continuously crank the starter more than 30 seconds. Stop cranking and allow the starter to cool for 2 minutes between cranking to avoid damaging the starter.

- If the starter motor still operates slowly, check the jumper connections to make sure they have good metal-to-metal contact.
- Once the engine is running, disconnect the negative cable from the starter, then from the booster battery. Disconnect the positive cable from the starter, then from the booster battery.
- After the engine is started, check all gauges for normal engine operation. If the gauges indicate a problem, stop the engine and determine the cause.
- If the engine fails to start after several attempts, check connections and retry or contact your dealer.

Exhaust Cleaning



Warning! During exhaust system cleaning operations, the engine may run at elevated idle and hot temperatures for an extended period of time. Exhaust gases and exhaust system components reach temperatures hot enough to burn people, or ignite or melt common materials. Keep machine away from people, animals, or structures which may be susceptible to harm or damage from hot exhaust gases or components. Avoid potential fire or explosion hazards from flammable materials and vapors near the exhaust. Keep exhaust outlet away from people and anything that can melt, burn, or explode.

Closely monitor machine and surrounding area for smoldering debris during and after exhaust filter cleaning.

Automatic Cleaning

To access the Exhaust Cleaning app, slide the main screen to the left until the Exhaust Cleaning app is visible. Touch the app icon (1) to continue to the next screen.

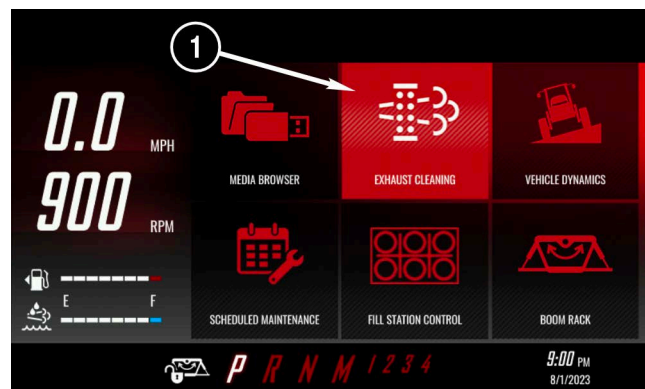

The button (2) will be filled in when in Automatic Mode. This will allow the machine to perform the exhaust cleaning when needed.

This is the recommended procedure for exhaust cleaning.



When the exhaust cleaning is in progress, the cleaning lamp (3) will be flashing, as well as the exhaust cleaning lamp. Also, both high exhaust cleaning lamps (3) will be on.

All lamps will be indicated at the top of the screen and under the Lamp Description section of the Exhaust Cleaning app.

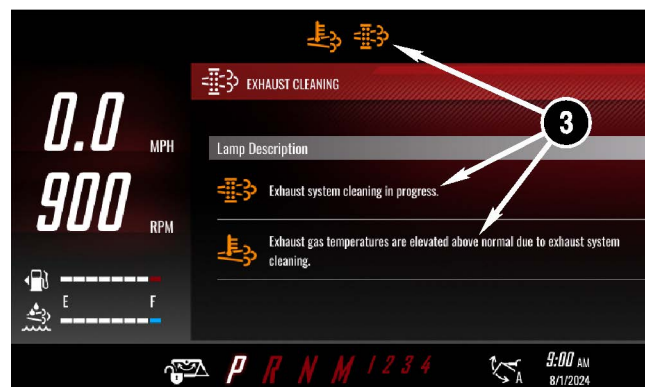

Disabled Mode

To access Disabled Mode, slide the main screen to the left until the Exhaust Cleaning app (1) is visible.

Touch the Exhaust Cleaning icon to continue to the next screen.

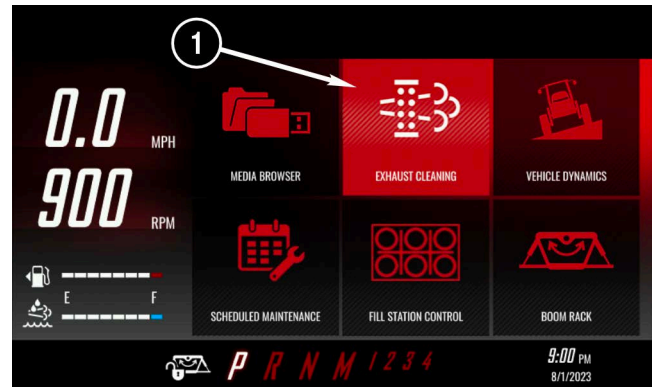

To change from Automatic mode to Disabled mode, touch the Disabled radial button (2). In this mode, the exhaust cleaning will not take place until it has been switched back to Automatic or activated manually. See "Manual Cleaning" on page 3-36.

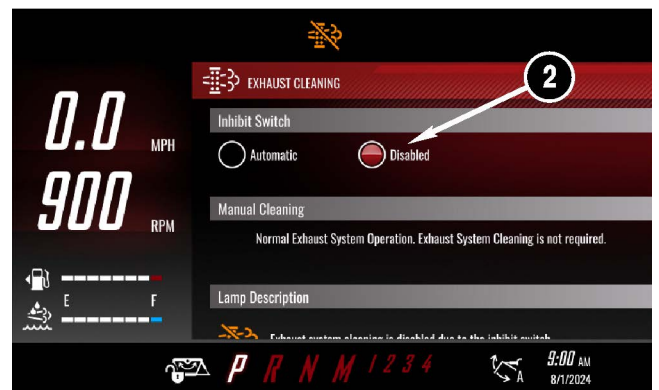

The Cleaning Inhibit Switch lamp (3) will be indicated at the top of the screen as well as under the Lamp Description section of the Exhaust Cleaning app.

It is recommended to switch to Disabled Mode if the machine will be running in confined locations such as a shop for maintenance.



Manual Cleaning

When the machine Exhaust Cleaning is disabled, the machine will determine when it is time to perform a cleaning. It will be indicated at the top of the screen with the Cleaning Required lamp (1). The manual cleaning option will then be available. Once the two criteria are met, Apply Park Brake and Idle Engine (2), the Begin button will be active to start the process.



Press the Begin button (1) to start the Exhaust Cleaning procedure. After the Begin button (1) has been pressed, the Inhibit Switch will be changed to Automatic (2). This will revert back to Disabled once the cleaning is complete.

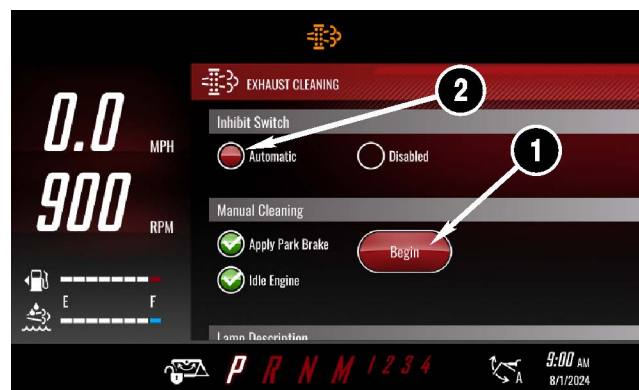

After the Begin button has been pressed, there will be a circle icon (1) that indicates that the process has begun. It will take a few seconds as the systems begin to communicate before the mechanical items begin to run through the steps of cleaning.



As the process moves to the next steps, the lamps will appear at the top of the screen as well as in the Exhaust Cleaning app screen. The Cleaning lamp (1) will begin to flash along with the solid High Exhaust Temperature lamp (1). The RPM's will also increase to 1000 (2) to assist in elevating the exhaust temperature.

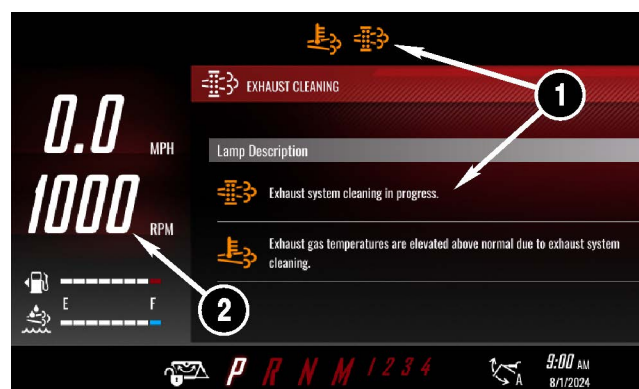

If the Park Brake is released or the Engine Idle is manually changed, the Exhaust Cleaning process will be aborted (1). Once the process has been aborted, the Inhibit Switch will revert back to Disabled (2). The process can be started again, once the criteria has been met.

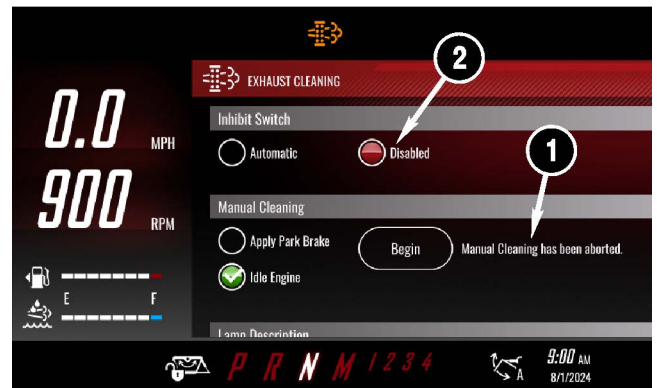

Low DEF Fluid

10% DEF fluid level:

A vehicle warning will pop up on the screen with the engine fault code and a brief explanation of the fault. Click on the OK button (1) to return to the main screen.

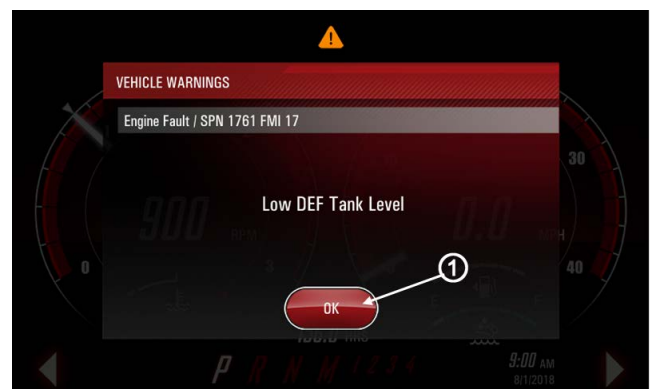

The Yellow warning lamp (1) and the Amber DEF lamp (2) will be on. Both lamps will remain in this state until DEF fluid is added.

To view a full description of the warning, press the Yellow warning lamp (1).

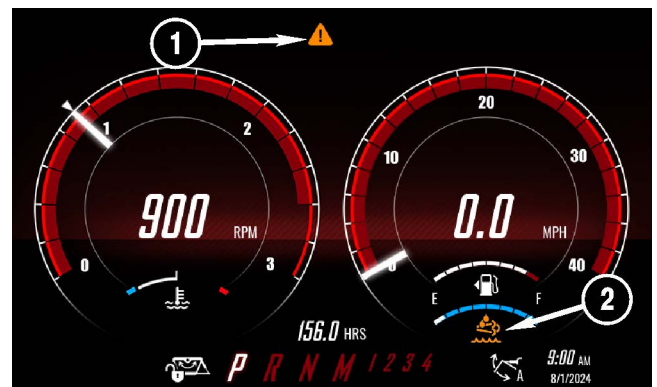

The Diagnostics/Faults page will give a full description (1) of the warning.

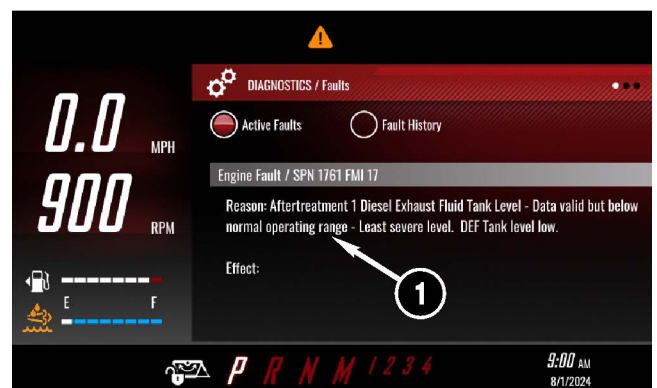

5% DEF fluid level:

A vehicle warning will pop up on the screen with the engine fault code and a brief explanation of the fault.

Click on the OK button (1) to return to the main screen.

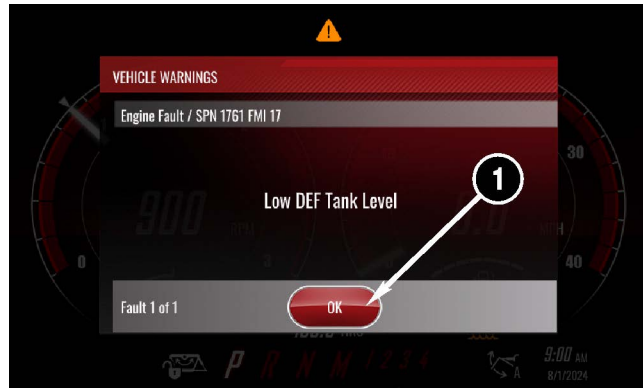

The Yellow warning lamp (1) and the flashing Amber DEF lamp (2) will be on. Both lamps will remain in this state until DEF fluid is added.

To view a full description of the warning, press the Yellow warning lamp (1).

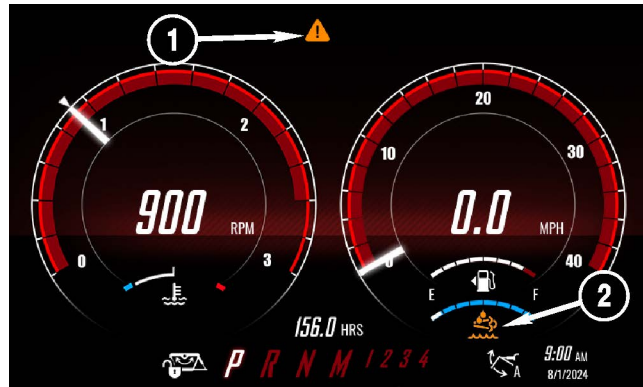

The Diagnostics/Faults page will give a full description (1) of the warning.

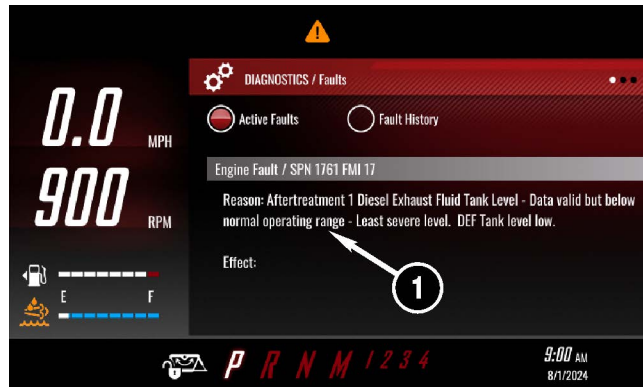

2.5% DEF fluid level:

A vehicle warning will pop up on the screen with the engine fault code and a brief explanation of the fault. Click on the OK button (1) to return to the main screen.

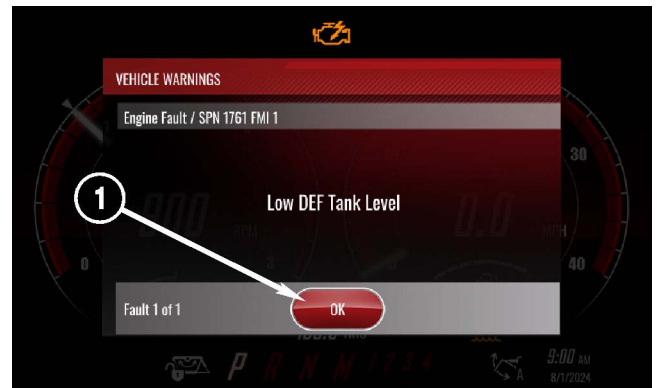

The Amber Engine Warning lamp (1) and the Flashing Amber DEF lamp (2) will be on. Both lamps will remain in this state until DEF fluid is added. **The first inducement derate will become active.**

To view a full description of the warning, press the Amber Engine Warning lamp (1).

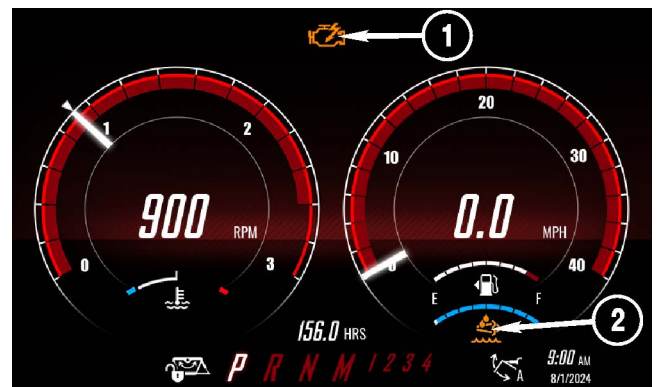

The Diagnostics/ Faults page will give a full description of the warning (1).

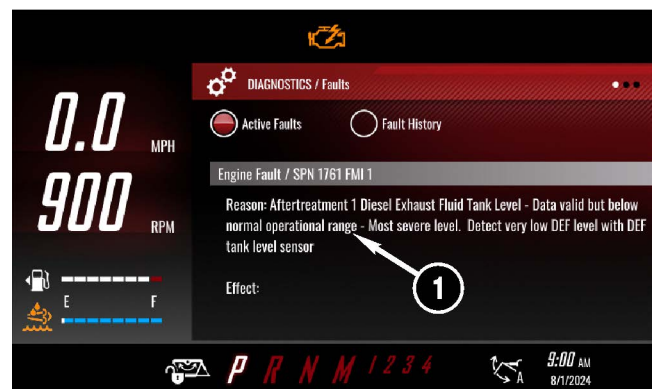

0% DEF fluid level:

Soon after the fluid is depleted, the Amber Engine lamp will change to Red Stop Engine Warning (1).

The final inducement derate will be applied (Engine torque derate, Low Idle lock).

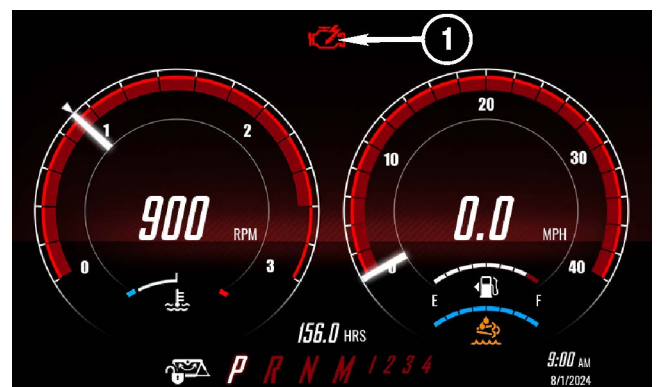

Vehicle Dynamics

To access the vehicle dynamics data, swipe to the second APP page. Touch the Vehicle Dynamics icon (1).

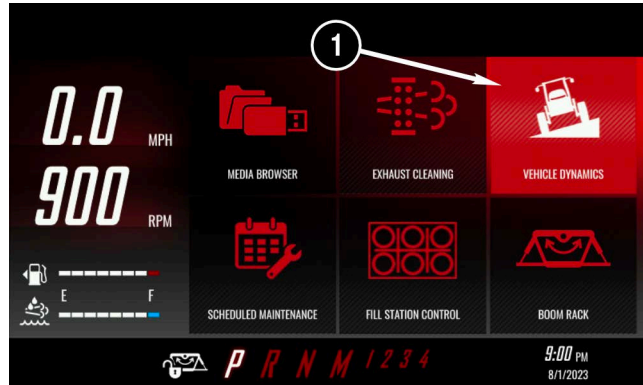

The Vehicle Dynamics screen will show the Degrees or Percentage of grade that the machine is on. To change between Degrees and Percentage, touch the screen on either value (1).

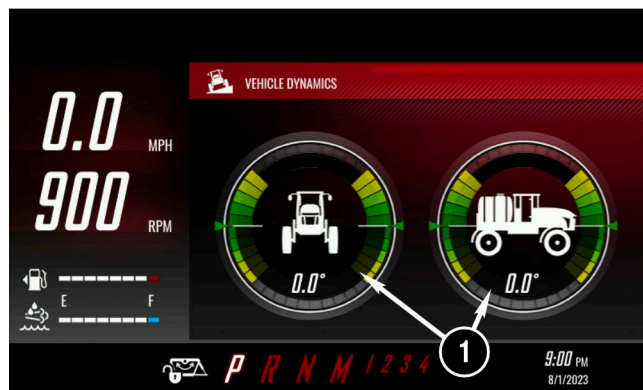

Boom Rack

This machine may be equipped with a rack locking feature as well as a rack auto leveling system.

Note: The rack should only be locked to fold, unfold, or transport the machine. The rack should not be locked while spraying. By default, the machine disengages the rack lock when the machine is traveling at or above 8 mph (13 km/h) to protect the boom system from damage.

To access boom rack features, slide the main display screen to the left until the 'BOOM RACK' app icon (1) is visible. Touch the icon to enter the app.

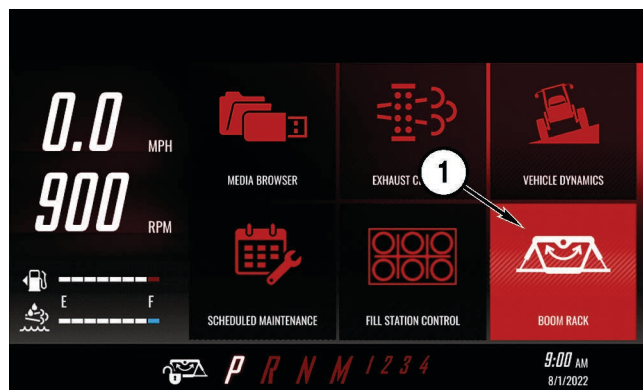

The main screen of the 'Boom Rack' app appears.

1. The lock status is displayed over the top of the rack image.
2. The angle of the rack relative to the chassis is displayed above the rack image.
3. The 'Rack Lock' button is located at top right.
4. The 'Auto Level' button is located at top left.
Note: If the rack is level, this button is grayed out.
5. The 'Rack Shift L' button is located to the left of the rack image.
6. The 'Rack Shift R' button is located to the right of the rack image.

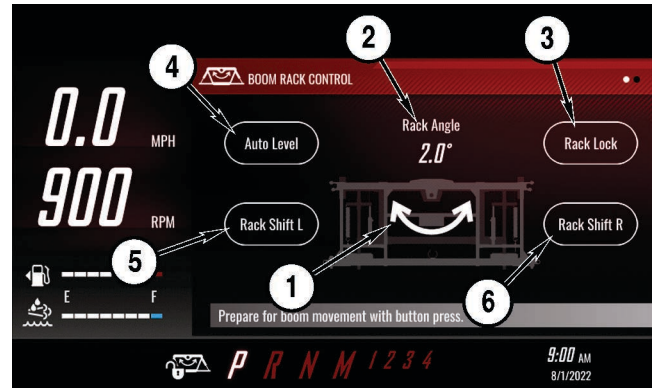

Rack Lock

To lock the rack, touch the 'Rack Lock' button (1) in the top right of the 'Boom Rack' app main screen.



When the rack is locked, an orange padlock (1) appears over the picture of the rack in the app screen as well as on the bottom row rack icon (2).



OPERATION

APACHE™

To unlock the rack, touch the 'Rack Unlock' button (1) in the top right of the 'Boom Rack' app main screen.

Note: When the sprayer reaches 8 mph (13 km/h), the rack will automatically unlock. Both the rack lock button on the app screen and the bottom row rack icon will be grayed out.

Note: If the autoboom feature is equipped, the rack will automatically unlock when the autoboom feature is engaged.

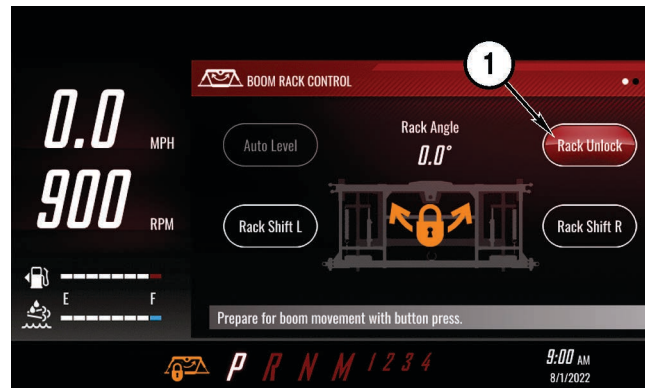

The rack can also be locked or unlocked from the main screen.

The rack lock icon (1) is located at the bottom left of the screen, to the left of the Park (P) icon. Touch the icon to lock or unlock the rack.

The icon is white and the padlock is open when the rack is unlocked.

The icon is orange and the padlock is closed when the rack is locked.

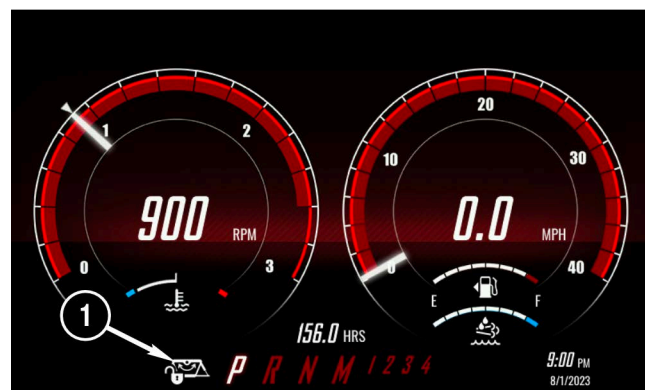

The rack can also be locked by pressing the padlock button on the keypad console (1). When the rack is locked a light will illuminate next to the padlock.

Press the padlock button (1) again to unlock the rack

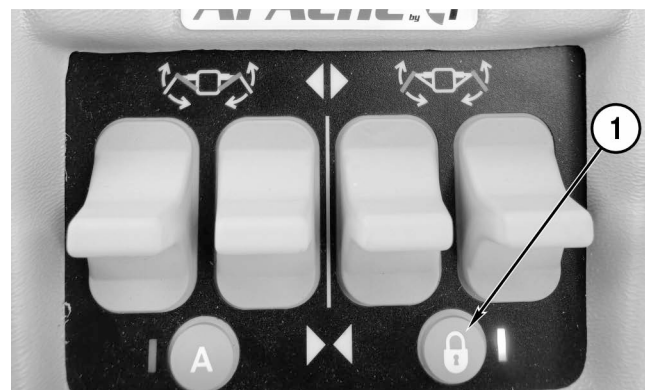

Rack Leveling (Manual)

The 'Rack Shift L' and 'Rack Shift R' buttons can be used to shift the rack in one direction or the other to obtain a level position before folding or unfolding.

If the left side of the rack needs to be raised, first lock the rack, then touch and hold the 'Rack Shift L' button (1) until the rack is level.

If the right side of the rack needs to be raised, first lock the rack, then touch and hold the 'Rack Shift R' button (2) until rack is level.

The rack can then be folded.



Rack Leveling (Auto Level)

Note: Before using the 'Auto Level' feature, ensure the booms are in an unobstructed area.

The 'Auto Level' feature is available for models equipped with an angle sensor at the center pivot of the rack.

If the rack is not level, the 'Auto Level' button (1) is enabled. Touch and hold the 'Auto Level' button until the rack and wings are in a level position.

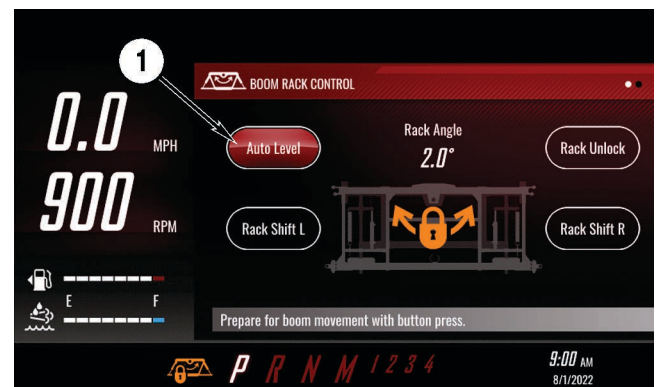

Rack Manifold Cleanout

The rack manifold and suspension cylinders are flushed from the factory, but air can enter the system over time.

If air is in the system, the manifold can be cleaned using the 'Boom Rack' app. Air in the system can be identified by a rack that continues to move when the rack lock is engaged.

Confirm the area is clear and the boom wings have adequate movement clearance.

Unlock the rack if it is locked.

Touch and hold the 'Rack Shift L' button (1) for at least 5 seconds. The rack may move some.

Release the 'Rack Shift L' button and touch and hold the 'Rack Shift R' button (2) for at least 5 seconds. The rack may move some. Release the 'Rack Shift R' button.

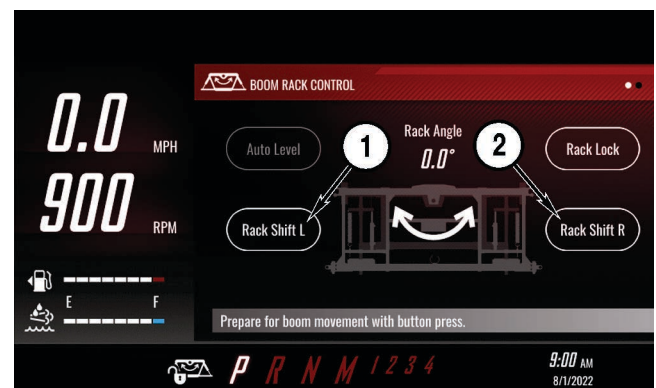

Rack Angle Calibration

To calibrate the rack angle sensor and to select machine equipment, slide the screen to the left to view page 2 of the 'Boom Rack' app.

If the machine is equipped with Raven autoboom XRT system, select the 'XRT CAN' option (1) under 'Rack Angle Sensor Type'.

If the machine is not equipped with autoboom, select the 'Analog' option (2).

If the machine is equipped with Raven autoboom XRT as well as the Raven Damping System, select the 'XRT Damper' option (3) under 'Rack Control Type'.

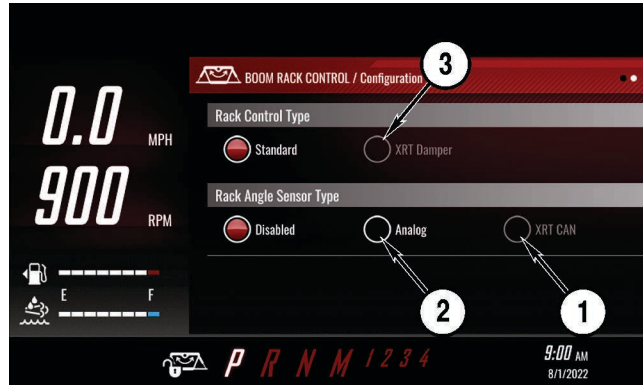

If 'Analog' sensor type (1) is selected, a calibration mode appears below the sensor type selection. The calibration must be performed before using boom rack features.

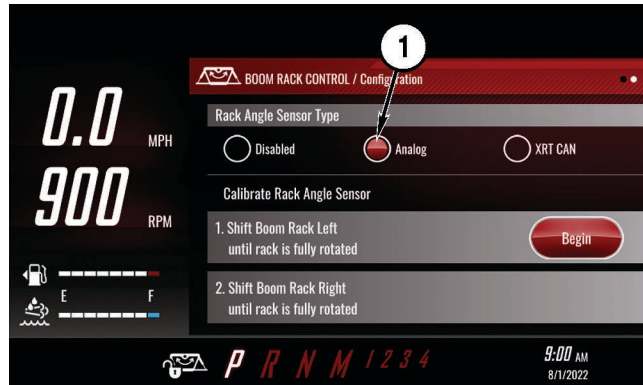

Following the calibration instructions, booms must be unfolded, parking brake applied, and booms must be in an unobstructed area.

Touch and hold the 'Rack Shift L' button (1) to obtain the first sensor output voltage. This will move the rack and wings to one extreme.

Touch the 'Done' button (2) when the rack and wings have stopped moving.

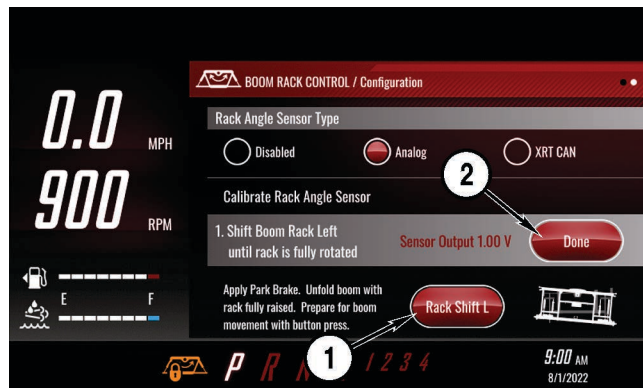

Touch the 'Begin' button (1) to start the second portion of the calibration.

Touch and hold the 'Rack Shift R' button to obtain the second sensor output voltage. This will move the rack and wings to the other extreme.

Touch the 'Done' button when the rack and wings have stopped moving.

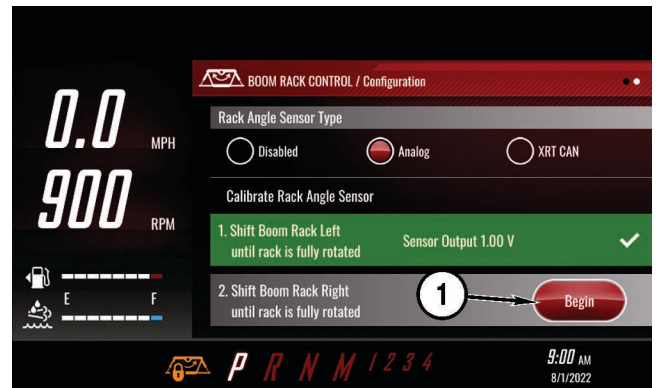

Both calibration steps are highlighted green and sensor output voltages are displayed after calibration is complete.

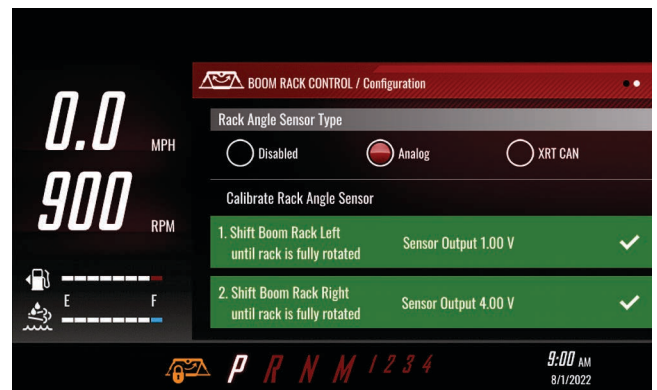

If XRT sensor type (1) is selected, the sensor will be calibrated through the Raven autoboom XRT calibration procedure. If the calibration does not give an accurate zero reading when the rack is level with the machine, the 'Rack Angle Zero Offset' (2) can be adjusted.

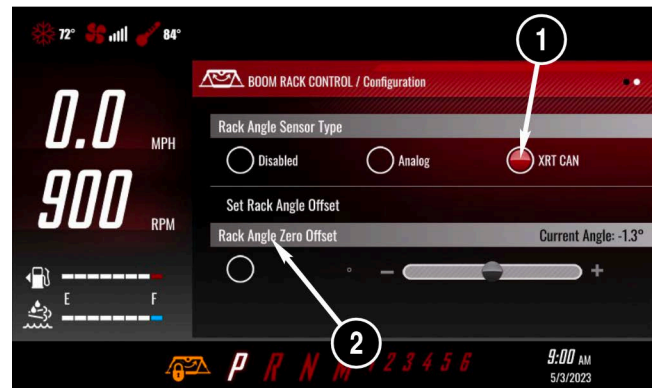

To adjust the offset, select the Rack Angle Zero Offset (2). The button below the offset menu will be red. Use the slider bar or the plus/minus icons to adjust the offset until the Current Angle (2) reading displays zero.

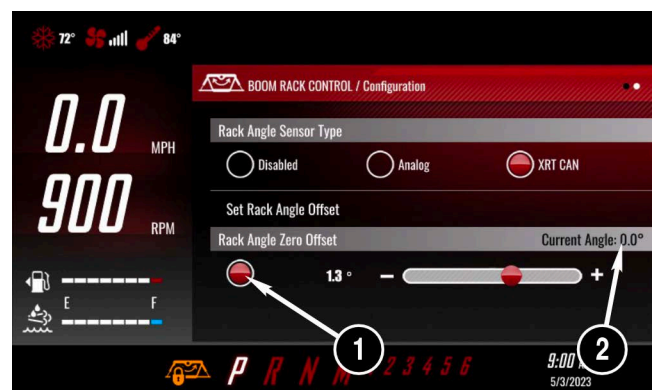

APACHE™

CHAPTER 4

WET SYSTEM OPERATION

NOTICE: Before performing any wet system operation procedures, read the Safety Section on page 2-1.

Wet System Overview

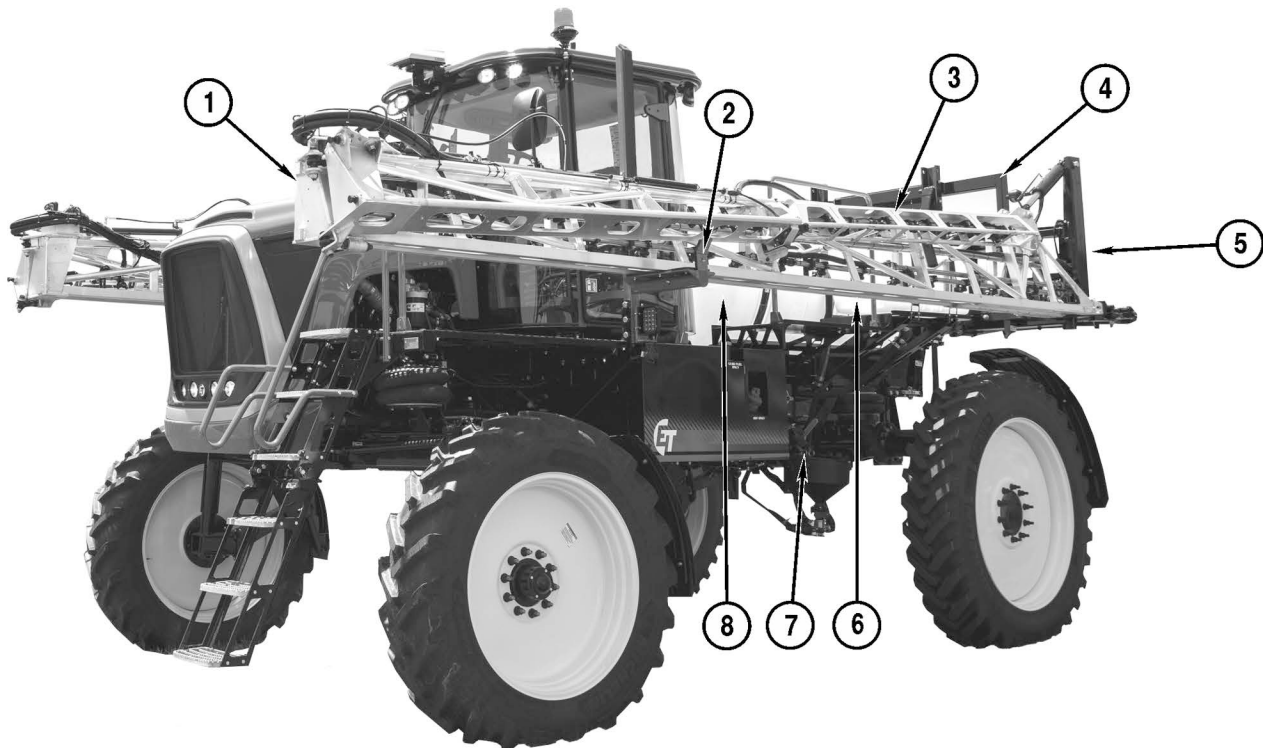

- | | |
|------------------|--------------------------------------|
| 1. Left Boom | 5. Flow Meter (not visible in image) |
| 2. Boom Cradle | 6. Rinse Tank |
| 3. Left Boom Tip | 7. Fill Station |
| 4. Boom Rack | 8. Product Tank |

Fill Station

1. **Key Pad Electric Valve**
LED lighted push button controls for product pump, Rotoflush, and agitate. See “Electric Valve Operation” on page 4-3.
2. **Product Valve (shown in OPEN position)**
This valve directs flow from the product tank to the pump or from the rinse tank to the pump.
3. **Rotoflush/Agitate Valve**
During normal spraying operation, this valve is electronically actuated and controlled by the buttons on the fill station keypad or in the cab.
4. **Product Tank Quick Fill**
5. **Air Connect**
Connect air hose to assist in cleaning booms or fill hose.
6. **Hand Rinse Valve**
This valve allows water from the rinse tank to be used for hand washing.
7. **Rinse Tank Quick Fill**

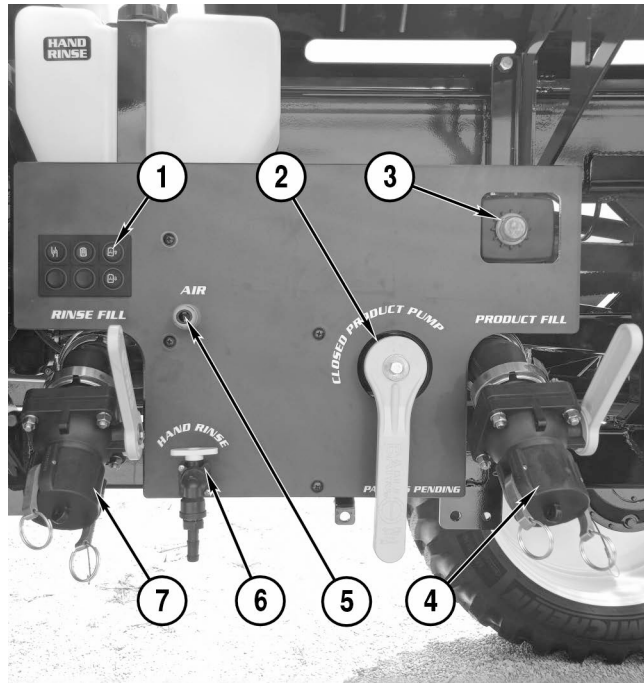

Key Pad Functions

1. **Rotoflush Button**
When pushed and the LED is green, the Rotoflush is ON. When pushed and the LED is red, the valve is CLOSED.
2. **Remote Product Pump Button**
When pushed and the LED is blue, the pump is ON. When pushed and the LED is red, the pump is OFF.
3. **Increase/Decrease Agitation Button**
There are two buttons for agitation. Pushing the top button will increase agitation, and pushing the bottom button will decrease agitation. Agitation can be increased/decreased incrementally by single button pushes, or rapidly by pushing and holding the button.

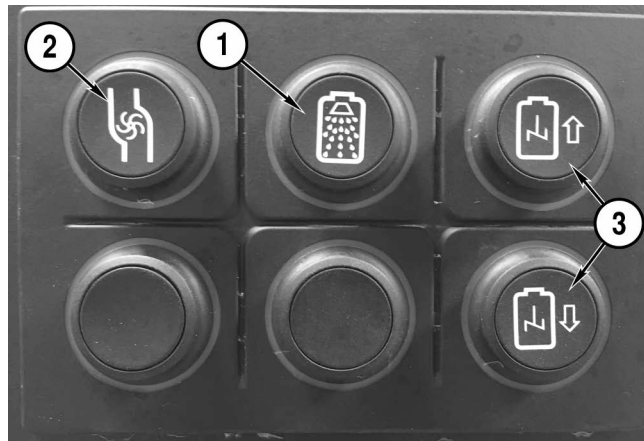

Electric Valve Operation

The electric valve is controlled by buttons on the panel just above the product fill. The buttons are encircled by LEDs that change color depending upon the operation status.

To switch between rotoflush and agitate valve positions, push the corresponding button.

- Select the rotoflush (item 1), and the LED will turn green.
- Select either agitate button (item 3) and the LED will turn blue.

When the electric valve is in motion to switch between the functions, the LED will rotate around the button.

- RED indicates an OFF or CLOSED status.
 - GREEN indicates ROTOFLUSH is selected.
 - BLUE indicates AGITATE is selected.
- (See “Button Feature Decal” on page 4-3.)

The control buttons on the fill station panel have corresponding buttons in the cab for remote operation. See “Touch Screen Controls” on page 4-4.

Button Feature Decal

The button feature decal is located on the inside of the glove box door.

The color of the word corresponds to the color of the light around the button when it is in that mode:

- RINSE: green (G)**
- SPRAY: blue (B)**
- CLOSED: red (R)**

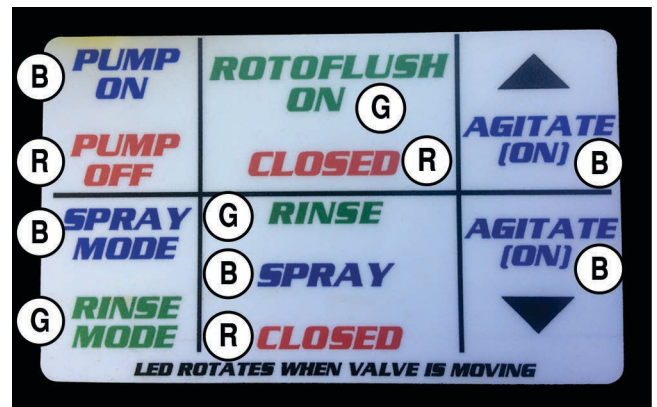

Touch Screen Controls

The touch screen has corresponding controls for the electric agitate/Rotoflush valve.

With the 3 inch option there are additional controls for the electric rinse/spray valve.



Touch Screen and Keypad Summary

The touch screen and fill station keypad can have the selections shown. Touch screen combination correspond with the keypad.

2 in Fill Agitate Pump



2 in Fill Agitate Pump OFF:

- Pump is RED.
- Agitates are BLUE.

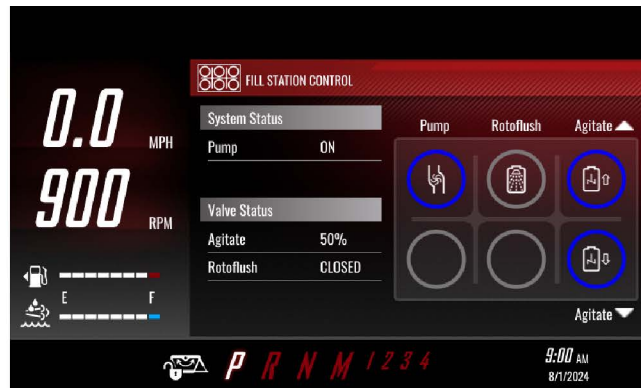

2 in Fill Agitate Pump ON:

- Pump is BLUE.
- Agitates are BLUE.

2 in Fill Rotoflush Pump



2 in Fill Rotoflush Pump OFF:

- Pump is RED.
- Rotoflush is GREEN.

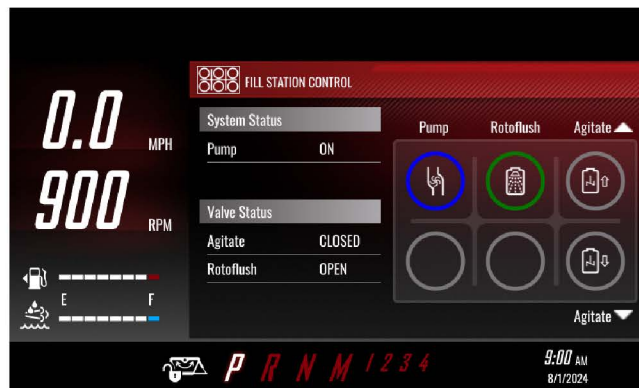

2 in Rotoflush Pump ON:

- Pump is BLUE.
- Rotoflush is GREEN.

Product Pump and Valves

1. Ace Product Pump

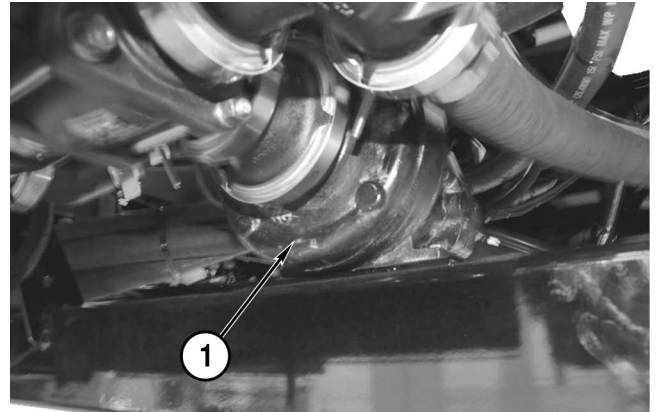

Sump Valve

1. Product Tank Sump Valve Shown in the OPEN position.

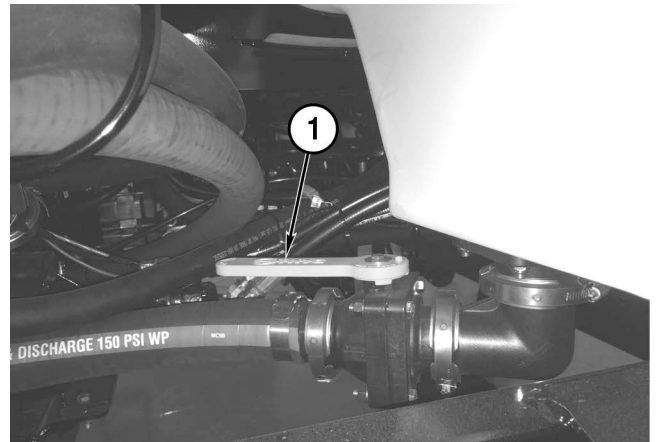

Flow Control

1. Flowmeter

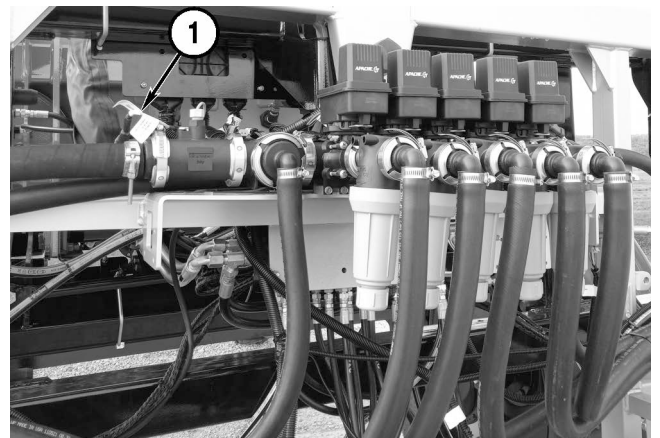

2. PWM Valve

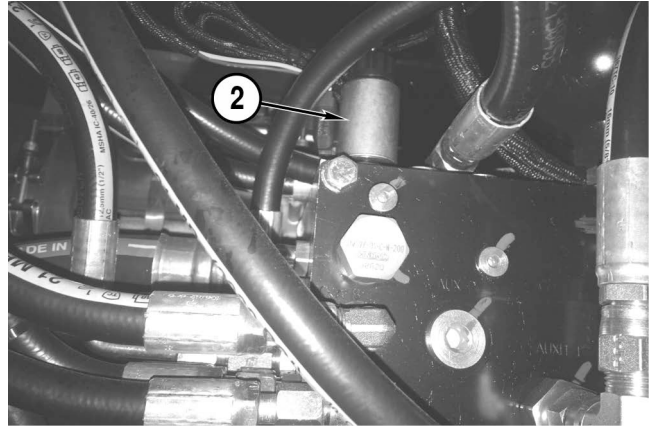

Electronic Boom Valves

The strainers (1) on the electronic boom valves (five section boom valve shown) have 50 mesh screens, that must be cleaned periodically.

NOTE: Apache sprayers equipped with individual nozzle control features will have 80 mesh screens in strainers.

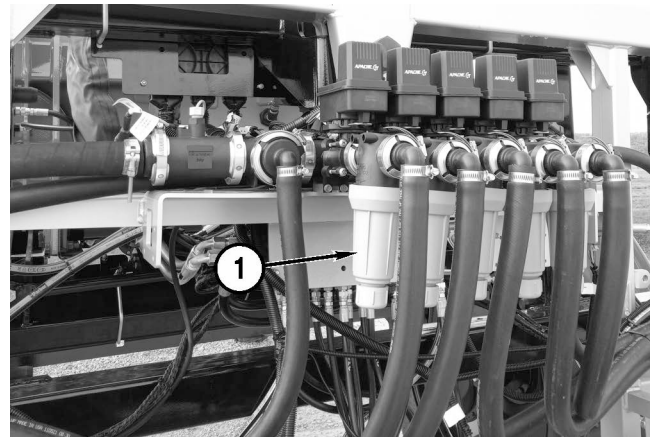

Viper® 4+ Monitor

Viper® 4+ Monitor is the Raven field computer option.

This monitor is built for Equipment Technologies by Raven. See the manufacturer's instructions, provided with the Apache Sprayer, for complete operating, calibration, and service information.



Monitor Calibration Information (for all Raven built monitors)

Speed cal (GPS for speed)1000

Meter cal.....See tag on the flowmeter, located on the rear boom rack.

Boom calThe boom cal numbers are specific for each sprayer and are dependent on the boom width, number of sections and nozzle spacing.

NOTE: All console calibration numbers should be recorded in the Apache owner's manual for future reference.

NOTE: These are factory presets. All controls must be calibrated before applying chemicals.

Side Console

1. Field Computer/Universal Terminal (option)
2. Master Spray Button
3. Boom Rack Buttons
4. Boom Tilt buttons
5. Left/Right Wing Switches
6. Left/Right Tip Switches
7. Agitate Up and Down Switch
8. Product Pump Button



Joystick

1. **Left Boom Tilt**
Press to tilt the left boom up or down. Press the top of the button to raise and press the bottom of the button to lower.
2. **Right Boom Tilt**
Press to tilt the right boom up or down. Press the top of the button to raise and press the bottom of the button to lower.
3. **Boom Center Rack Up/Down**
Press to raise or lower the boom mast. Press the top of the button to raise and press the bottom of the button to lower.
4. **Master Spray Switch**
Press to turn on or off all boom sections that are in the on position on the switchbox.



Filling Product Tank

Open the sump valve (1) on the underside of the product tank.

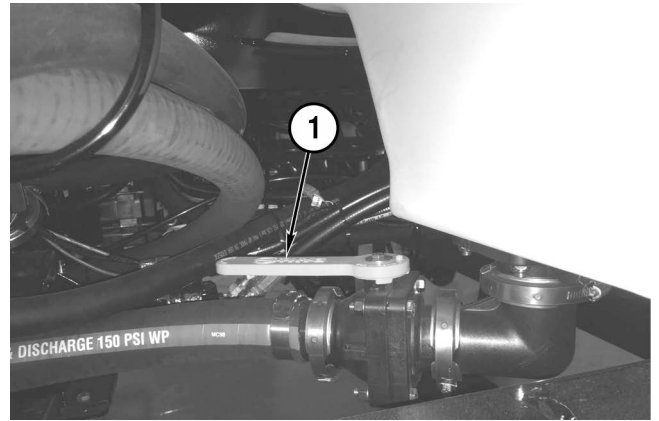

Remove the cap from the product quick fill inlet (1) and connect the hose from the nurse tank to the inlet.

Open the product fill valve (2), shown in the CLOSED position, and fill tank to desired level. There is a product tank sight gauge on the front of the tank.

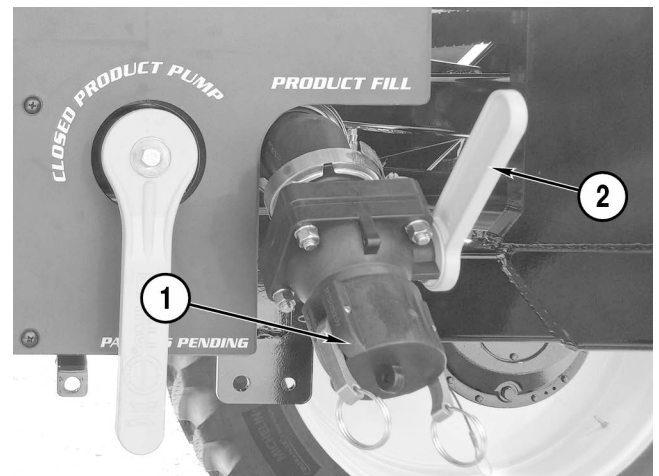

When filling is complete, close the valve on the nurse tank, then close the product fill valve.

Disconnect the hose from the inlet and install the quick fill inlet cap.

Filling Rinse Tank

Remove the cap from the rinse quick fill inlet (1) and connect the hose from the nurse tank to the inlet.

Open the rinse valve (2), shown in the CLOSED position and fill to the desired level. There is a tank level indicator tube on the back side of the tank.

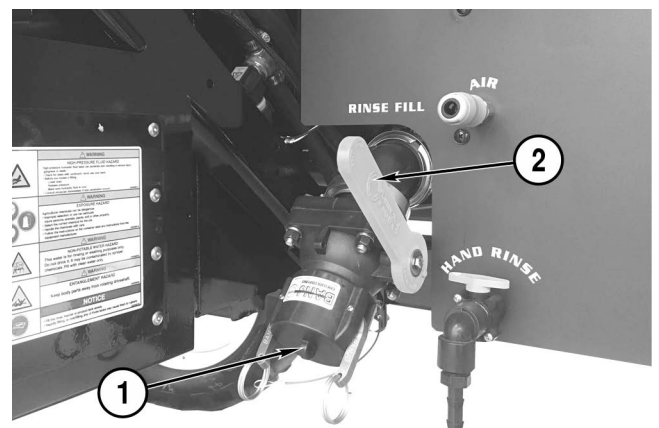

IMPORTANT: Fill the tank slowly. Rapid filling or overfilling may rupture the tank.

When filling is complete, close the valve on the nurse tank, then close the rinse fill valve.

Disconnect the hose from the inlet and install the quick fill inlet cap.

Operating Booms

Before performing any boom operations, read all the following safety messages and take all necessary precautions to avoid personal injury and equipment damage.



WARNING! Electrocutation Hazard. DO NOT fold or unfold the booms near power lines.



WARNING! Control Hazard. NEVER fold or unfold the booms while the Apache Sprayer is moving over 5 mph [8.04 km/h] or with the optional Auto Boom height control turned ON.

Tilt to Remove Boom from the Cradle

On the joystick, press the top of the left (1) and right (2) boom tilt raise/lower switches to raise the booms off of the boom cradles (3).

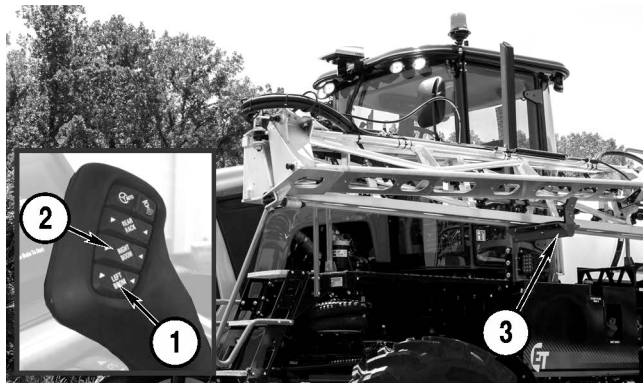

Unfold Boom Wings

NOTICE: Lock boom rack before unfolding. Rack movement could cause damage or injury.

On the console keypad, press and hold the Left and Right Wing buttons, (1) until the boom wings are fully extended.

After the boom wings are fully extended, the boom tips can be unfolded.



Unfold Boom Tips

NOTICE: The booms must be unfolded before the boom tips can be extended. The machine can be damaged if the booms are not unfolded properly.

On the console keypad, press and hold the Left and Right Tip buttons (1) until the boom tips are fully extended.



Height Adjustment

On the joystick, press the bottom of the boom rack raise/lower switch (1) to lower the boom rack (2) to the desired height.

Press the top of the switch to raise the boom rack.

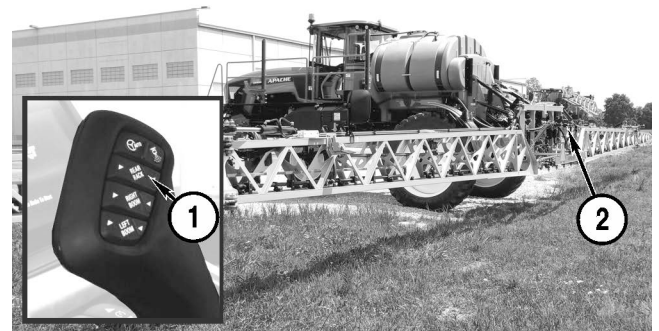

Tilt to Level Boom

On the joystick, use the Left (1) and/or Right (2) boom tilt raise/lower buttons to adjust the booms to level.

Press the top of the buttons to tilt the boom up and the bottom of the buttons to tilt the booms down.

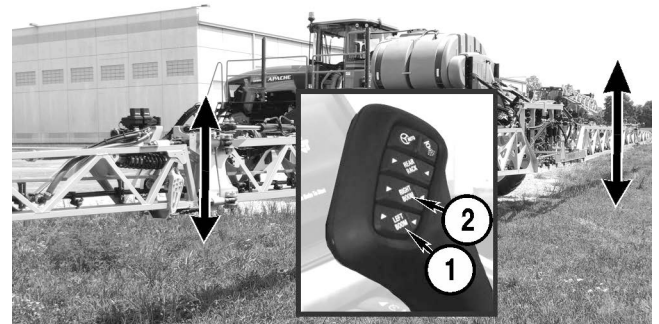

Fold Boom Tips

On the console keypad, press and hold the Left and Right Tip buttons (1) until the boom tips are fully folded.

After the boom tips are fully folded, the boom wings can be folded.



Fold Boom Wings

NOTICE: ALWAYS raise the rack and the left and right boom tips completely before folding the booms.

On the console keypad, press and hold the Left and Right Wing buttons (1) until the boom wings are fully folded.

Lock boom rack before folding. Rack movement could cause damage or injury.



Tilt to Return Boom to Cradle

On the joystick, press the bottom of the left (1) and right (2) boom tilt raise/lower buttons to tilt the booms onto the boom cradle (3).

With the booms properly stored, the Apache Sprayer is ready for transport.

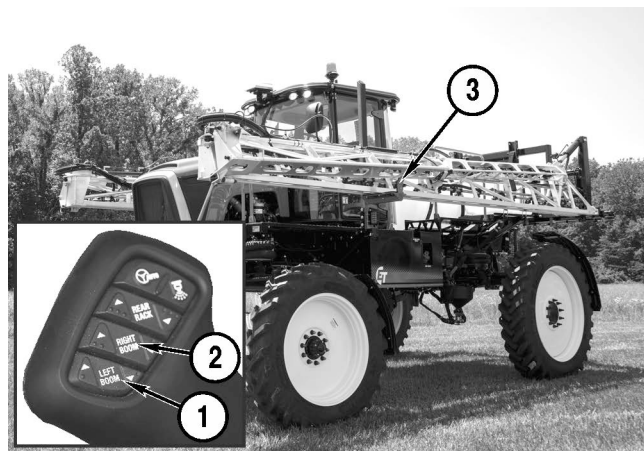

AutoFold (If Equipped)

The AutoFold function is accessed in the touch screen. The icon is located below the speedometer and to the right of the gear indicator (1).

For ET AutoFold, diagnostics and calibrations can be found in the settings menu of the display. Additional information can be found in this manual under Vehicle Settings.

For Raven AutoFold, supplemental AutoFold information is in the Raven Viper 4+ screen. Refer to the Raven manual for additional information.

The AutoFold icon appears on the touch screen once AutoFold is unlocked and calibrated.

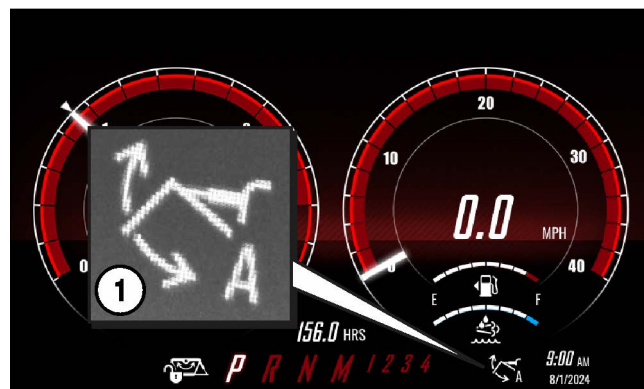

NOTE: Booms can always be operated with the standard Unfold/Fold functions on the joystick and keypad. Using these buttons will abort the AutoFold function.

NOTE: The Unfold/Fold process will “time-out” when an electrical process is taking too long. The screen will return to the start screen.

NOTE: The end user climate can impact AutoFold performance if it is considerably different from the climate of calibration. Contact dealer if you suspect this performance issue.

Unfold

1. Touch the AutoFold icon on the touch screen.
2. When the Operator Liability screen appears, read and understand the liability warnings. Touch OK to accept the liability agreement.
3. The Safety Check screen appears next. In order for AutoFold to function the following safety requirements must be met:
 - Speed is zero
 - Brakes are engaged
 - Operator is sitting in seat
 - Rack is level (ET AutoFold only)
A check mark confirms the requirement has been met.
4. Touch and release the Unfold button.
The booms will tilt and unfold automatically.

NOTICE: If any of the safety requirements are not met during unfold or if any boom button is pressed, the function will be aborted.

The unfold function can be reengaged by once again meeting the safety requirements and touching the Unfold button.

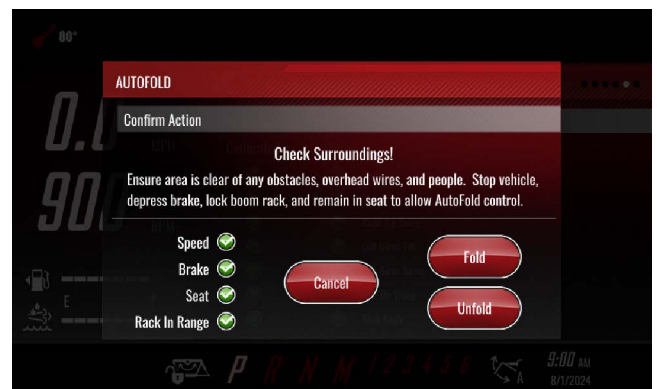
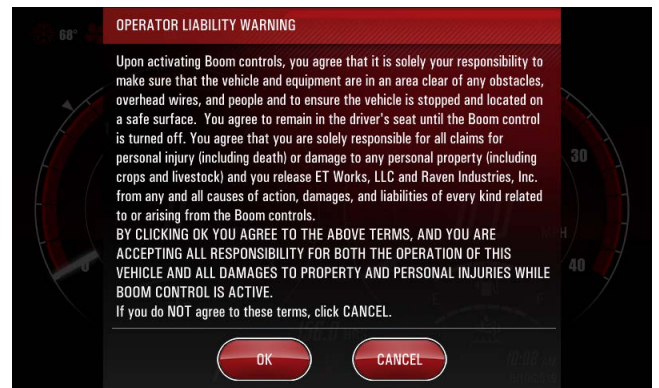

Fold

1. Touch the AutoFold icon on the touch screen.
2. The Safety Check screen appears next. In order for AutoFold to function the following safety requirements must be met:
 - Speed is zero
 - Brakes are engaged
 - Operator is sitting in seat
 - Rack is level (ET AutoFold only)
A check mark confirms the requirement has been met.
3. Touch and release the Fold button.
The booms will fold and return to cradles automatically.

NOTICE: If any of the safety requirements are not met during fold or if any boom button is pressed, the function will be aborted.

The fold function can be reengaged by once again meeting the safety requirements and touching the Fold button.

Spraying

Make sure the product, rinse, and foam marker tanks are filled. See “Operating Booms” on page 4-10. See “Filling Product Tank” on page 4-9. See “Operating Booms” on page 4-10.

Level the booms and boom tips using the tilt and unfold buttons. See “Operating Booms” on page 4-10

Set the boom height using the boom rack button. See “Height Adjustment” on page 4-11.

Open the sump valve (1) on the underside of the product tank.

NOTICE: ALWAYS read and follow all chemical labels and follow all federal and state laws when applying chemicals.

Set the product valve (1) to PRODUCT TO PUMP.

Push either agitation button (2).

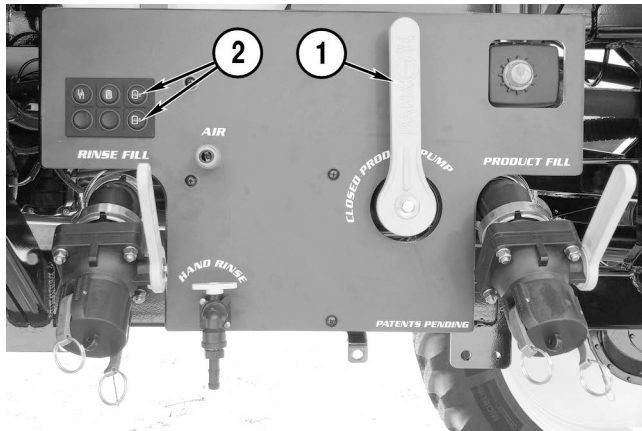
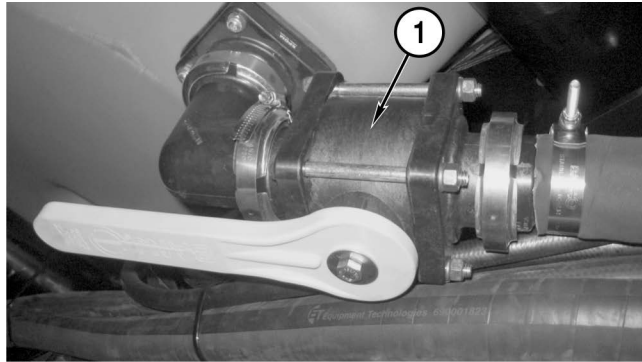

The product strainer (1) features 50 mesh screens, which should be checked and cleaned after every 50 hours of operation or as needed.

NOTE: Depending on the chemicals being applied, it may be necessary to substitute the 50 mesh screen with a more coarse strainer. See the chemical manufacturer’s instructions for complete details.

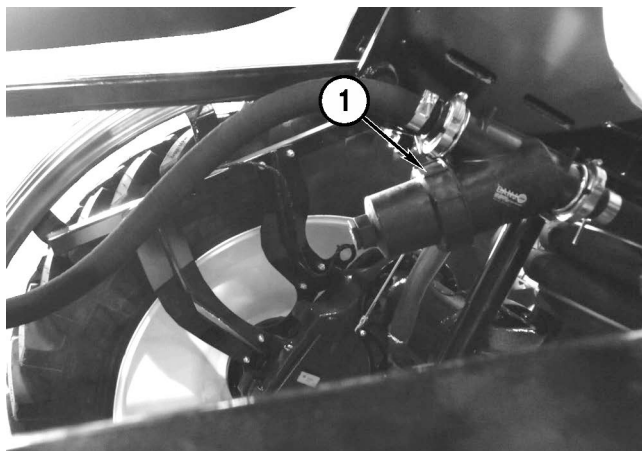

Power up the Viper® 4+ and check the settings.

Select a saved flow rate or enter the desired rate. See the respective controller's manual supplied with the Apache Sprayer for complete operating instructions.



Set the product pump button (1) to the ON position.

Set the desired boom section to the ON position.

IMPORTANT: DO NOT run the product pump dry. Damage to the pump seals will result. DO NOT intentionally dead-head the pump with high pressures. Damage to the pump seals will result. Product pump dead-head pressure with agitation closed should be 120 psi with the hydraulic oil at operating temperature.



Select an appropriate gear for the desired Apache Sprayer speed during spraying.

See “Shifting Forward Gears” on page 3-25. Under typical operating conditions, second or third gear is recommended.

Use the master spray on/off button on the joystick (1) to start and stop spraying.

Use the Viper 4 to control boom sections to start and stop product flow to individual boom sections if necessary. The console controller will automatically adjust the product flow for the remaining sections.

Use the Viper 4 to control the two optional fence row sections.



Quick Spray Mode (Compatible with Raven Spray Control Module only)

Quick Spray Mode is a simple spraying function that does not use the field computer.

NOTE: Quick Spray will only work if the field computer is OFF or is set to Manual mode.

From the main start screen, swipe left once.

1. Select Quick Spray on the touch screen to go to the parameters screen.
2. The plus (+) and (-) buttons allow the operator to increase or decrease the pump **PWM** by 0.5% increments. Touching and holding the button will allow the value to change quickly.
3. **Boom Pressure**, (psi) as measured by the product controller.
4. **Application Rate**, (gallons/acre) as calculated by the product controller.
5. **Sparge Pressure**, (psi) as measured by the product controller. This can be manipulated by the agitate buttons on the pilot system.
6. **Manual Section Control**, the nine boom sections can be controlled by the corresponding nine triangles when the field computer display is OFF or in Manual mode. Each triangle can be pressed to toggle that section valve on/off. Make sure the Master Spray on the joystick is pushed on. The valve status is indicated by color.

OFF = Gray

ON = Blue (both Master Spray and section valve)

NOTE: If field computer display is ON or in Automatic mode, the triangle icons **cannot** be used to toggle the valves. Color still indicates status of the valve being on or off.

NOTE: The fence row nozzle cannot be controlled with Quick Spray.

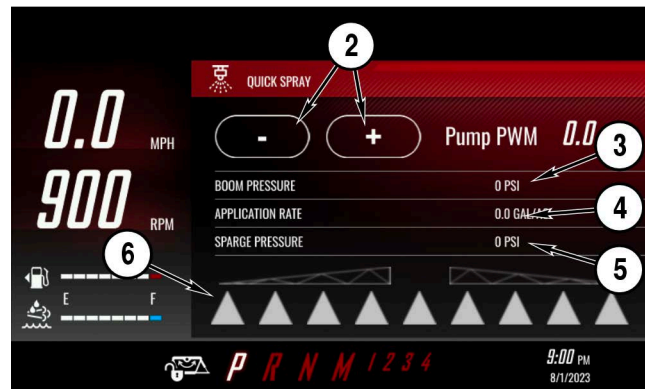
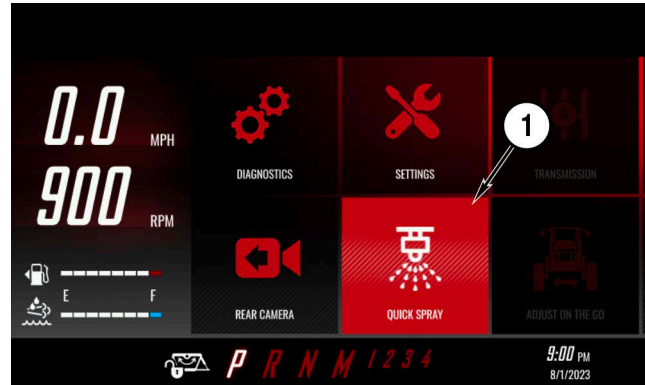

Optional Fence Row Nozzle

The Apache sprayer can be equipped with optional left, and/or right fence row nozzles. If equipped, the fence row nozzles (1) and actuator solenoids (2) are plumbed into the first boom section on the left and the last boom section on the right (left side shown). Therefore, the respective section must be on for the fence row nozzle to operate.

To operate the left fence row nozzle, boom section 1 and boom section L must both be switched on.

To operate the right fence row nozzle, the highest configured boom section and boom section R must both be switched on.

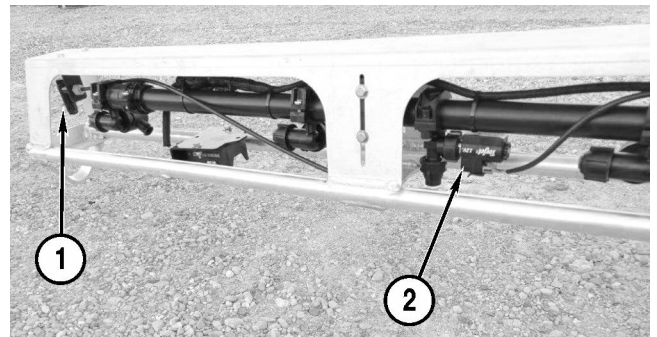

Flushing Product Tank

NOTICE: Read and follow chemical labels for flushing, disposal, and protective clothing requirement instructions.

NOTICE: DO NOT run the product pump dry. Damage to the pump seals will result. DO NOT intentionally dead-head the pump with high pressures. Damage to the pump seals will result.

Fill the rinse tank with clean, fresh, water. See “Operating Booms” on page 4-10.

Turn the product valve to RINSE TO PUMP (1).

Push the Rotoflush button (2) to ON, LED is GREEN.

Start the engine.

Push the product pump button (3) to the ON position, LED is BLUE, and increase engine speed to approximately 1200 rpm.

NOTICE: The rinse tank will empty quickly. Monitor the process closely to reduce the possibility of running the product pump dry.

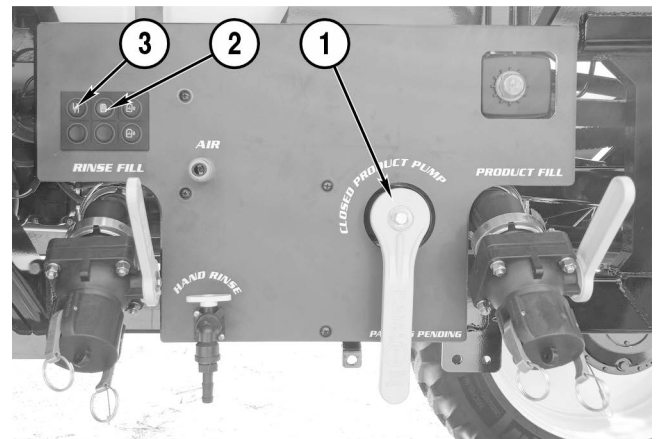

After the tank is rinsed:

- Return the engine to IDLE.
- Push the product pump button (1) to OFF, LED is RED.
- Turn the product lever (2) to PRODUCT TO PUMP.
- Push the roto-flush button (3) to OFF, LED is RED.
- Drain tank safely through the Product Tank Fill Valve.

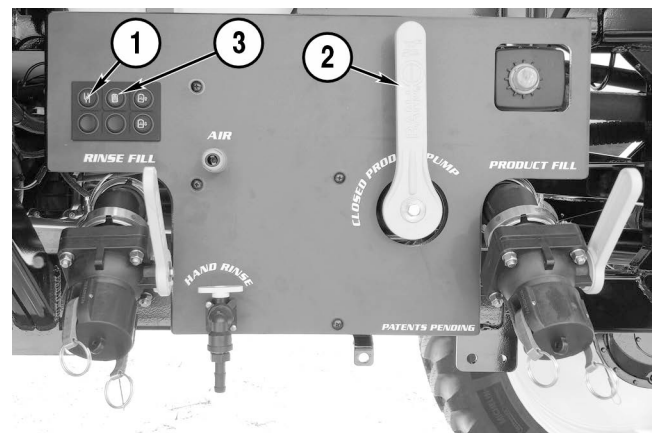

Flushing Booms

NOTICE: Read and follow chemical labels for proper usage, flushing, disposal and protective clothing requirement instructions. ALWAYS dispose of chemicals and contaminated rinse water in a safe location in accordance with chemical label recommendations and local laws.

NOTICE: Some chemicals may require multiple tank flushings.

NOTICE: DO NOT run the product pump dry. Damage to the pump seals will result. DO NOT intentionally dead-head the pump with high pressures. Damage to the pump seals will result.

To flush the booms:

- Unfold the booms.
- Turn the product valve (1) to RINSE TO PUMP.
- Remove Hypro Express Endcaps.
- Increase engine speed to 1200 rpm.
- Switch to Manual Spray in the field Computer.
- Push the Product Pump button (2) to ON, LED is BLUE.
- Press the Master Spray Button to flush.

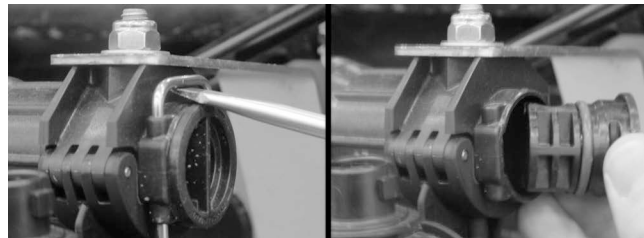
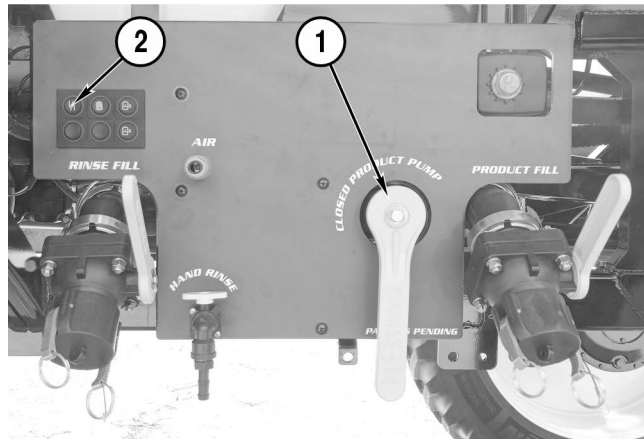

NOTE: If the Apache Sprayer is equipped with an optional chemical eductor, flush the eductor at the same time as the booms.

After the booms are flushed:

- Turn OFF Master Spray Button
- Return the engine speed to IDLE.
- Push the product pump button (2) to OFF, LED is RED.
- Set the product valve (1) to PRODUCT TO PUMP.
- Replace the Hypro Express Endcaps
- Fold the booms and turn off the engine.

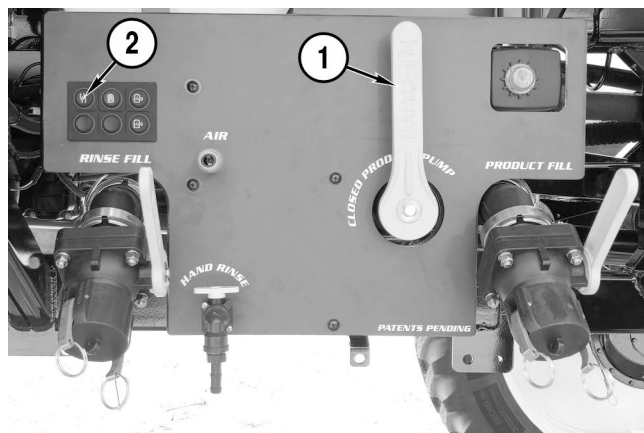

Cleanload Chemical Eductor

The eductor assembly is automatically lowered and raised with the use of the park brake button. When the park brake is activated, the eductor is lowered. When the park brake is deactivated, the eductor is raised.

Startup

1. All eductor valves must be closed prior to starting. Close the inlet ball valve (1) and the hopper ball valve (2).
2. Open the lid to check for foreign objects which may hinder performance or contaminate the system.
3. Close and lock the lid by turning the cover clockwise.
4. Divert pump flow to the eductor inlet line by pulling the valve (3) to the open position.

NOTICE: A pressure of 30 psi [2.06 bar] minimum and 150 psi [10.3 bar] maximum must be used. Higher pressures increase eduction rate and available wand suction.

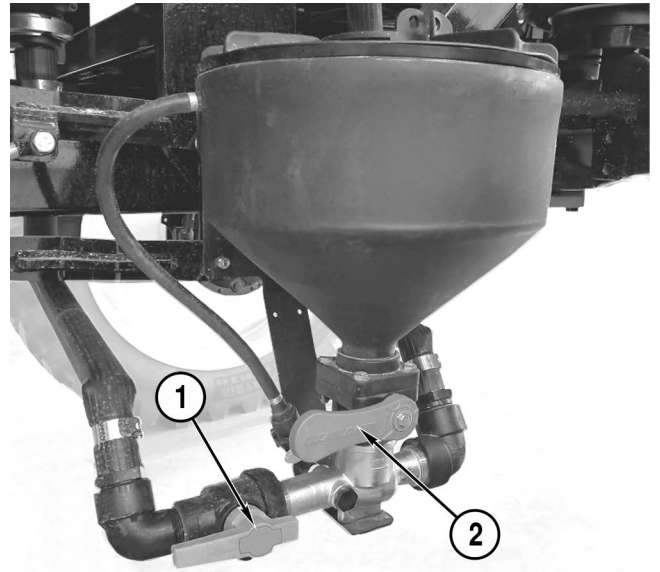

5. Turn the yellow handle of the inlet ball valve (1) to the open position.
6. Open the hopper ball valve (2), located on the bottom of hopper, by rotating the handle into a vertical position.
7. Unlock and open the lid slowly by turning the cover counterclockwise.
8. Load the eductor. Loading instructions differ for eductors equipped with an optional suction lance. Use the procedure that is appropriate for your application.

Loading Liquid or Powdered Chemical into Hopper

NOTICE: DO NOT at any point put your face directly over the hopper.

NOTICE: Avoid splashing liquids or powdered chemicals outside of the hopper.

1. Pour required amount of chemical into the hopper.
2. Rinse empty chemical containers if applicable. Place container opening over the container rinse valve and press down. This will activate the rinse valve and rinse the container.
3. Rinse the Cleanload hopper.
4. Close and lock the lid by turning the cover clockwise.
5. Open the eductor valve (3) for 20 seconds, then close the valve.
6. Open the lid and inspect for chemical residue. Repeat steps 3 to 5 as necessary.
7. Close the hopper ball valve (2) by rotating the handle into a vertical position. Turn the inlet valve (1) (yellow handle) off.

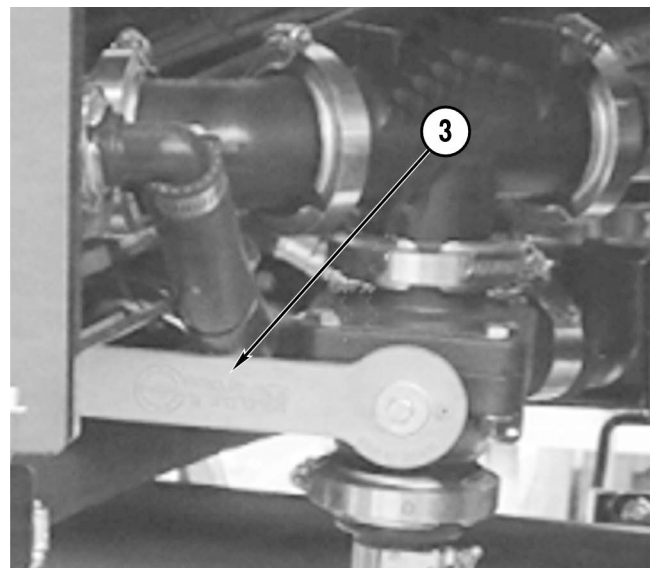

NOTE: The eductor hoses are flexible and may be kinked while in the up position. This is normal and will not cause any damage to the hoses or equipment. Make sure that the inlet valve (3) behind the fill station has been shutoff before raising the eductor.

Boom Recirculation (Optional Equipment)

If equipped, the sprayer will have boom recirculation plumbing installed allowing for continuous flow of product throughout the boom plumbing.

Operation

When the recirculation system is active, the spray system is not spraying, nozzle control valves (NCVs) are off, and the electric return valve (1) is fully open. The main pump circulates the spray liquid from the main tank through the existing supply plumbing to the section valves.

The section valves turn on and off to circulate fluid for each section of the spray system. This keeps the liquid circulating, allowing the system to purge any air, break up chemical deposits, and agitate any separated chemicals through the system without the need to spray out of the nozzles.

Product returns through the manual throttling valve (4) and electric return valve (1) until spraying resumes.

The manual throttling valve is used to dampen the pressure spike effects of the electric return valve closing when spraying resumes. The individual recirculation hand valves should be used to separate sections when not using nozzle control valves (NCVs) and to isolate boom plumbing sections if maintenance is required or damage has occurred.

NOTE: It is recommended to rinse the system with the boom unfolded to prevent circulating with pinched supply hoses.

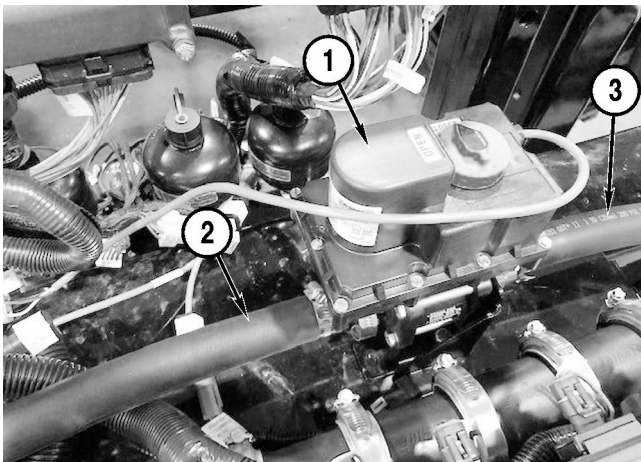

1. Electric Return Valve
2. Hose to Product Tank
3. Hose from Boom Plumbing

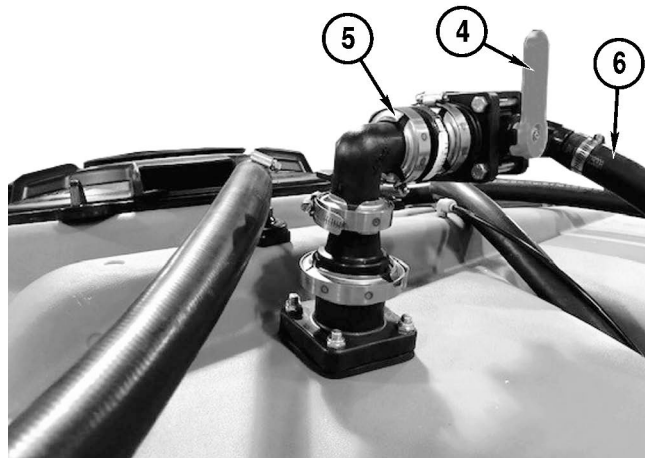

4. Manual Throttling Valve
5. Check Valve
6. Return Hose.

General Boom Recirculation Diagram

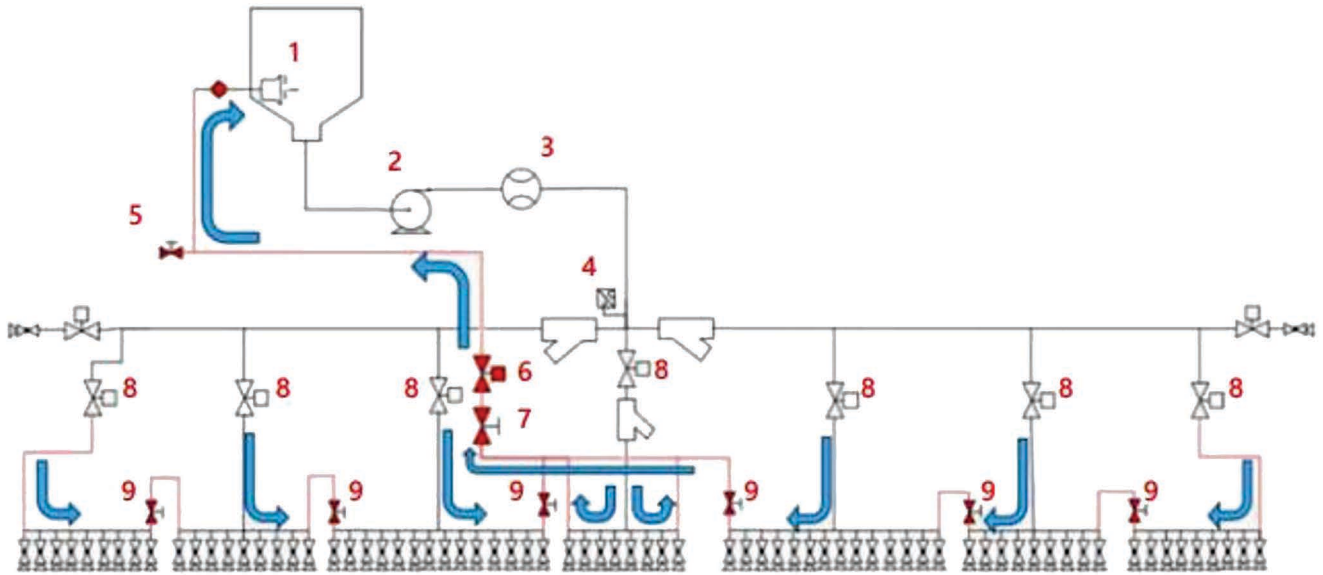

- | | |
|-----------------------------|-------------------------------|
| 1. Main Tank | 6. Electric Return Valve |
| 2. Main Pump | 7. Throttling Valve |
| 3. Main Flow Meter | 8. Section Valves |
| 4. Boom Pressure Transducer | 9. Recirculation Hand Valves. |
| 5. Drain Valve | |

Required Conditions for Recirculation

The following conditions are required to initiate the boom recirculation feature:

- Confirm the Boom Recirculation feature is enabled.
- Ensure the tank fill feature is not enabled.
- Toggle the product pump on.
- Ensure all boom sections are toggled on.
- Ensure the active spray width is zero.
- Recirculation hand valves between sections must be open.
- Either enable the Auto Recirculate feature or manually initiate recirculation on the universal terminal (UT).

Auto-Recirculation

The auto recirculate option allows the system to automatically start the recirculation sequence when the active section application width is zero (all sections turned off). If the auto recirculate feature is not enabled, the operator must activate recirculation manually using a button on the universal terminal (UT).

NOTE: Whether set for manual or automatic recirculation, recirculation will automatically turn off when spraying resumes.

Setup (Raven Boom Recirculation Specific)

To turn on main product recirculation:

1. Open the universal terminal (UT) menu and select the RCM-Sprayer menu button.
2. Select the Tools menu soft key along the right side of the display.
3. Select the Rates Setup tab along the top of the display.
4. Select the User Settings tab and select the Next button in the lower, right corner twice to display the Boom Recirculation check box option.
5. Enable the Boom Recirculation feature.

Setup Enable Main Product Recirculation

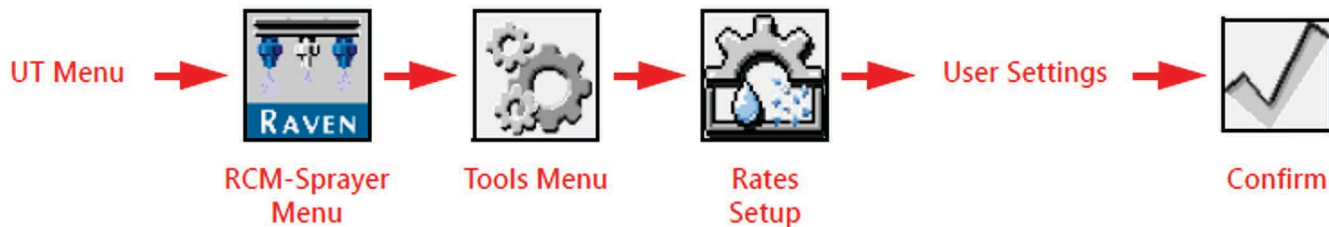

NOTE: The system will display a prompt for the operator to confirm that the plumbing of the system will support boom recirculation features. Once confirmed, the Boom Recirculation soft key will be displayed on the home page.

6. Enable the Auto Recirculate feature to allow the system to automatically initiate the recirculation system anytime the system is not spraying.

NOTE: Recirculation will always stop automatically when normal spraying is initiated, when tank fill operations are started, when the main product is turned off, or when a direct injection product is turned on. The operator may also manually stop recirculation by selecting the Recirculation soft key on the home page. Pressing this button disables the Auto Recirculation feature and returns the system to Manual Recirculation Mode.

7. The Boom Recirculation soft key will be displayed on the universal terminal (UT) home page.



Adjust Recirculation Times

To adjust the time allowed for recirculating each section:

1. Open the universal terminal (UT) menu and select the RCM-Sprayer menu button.
2. Select the Tools menu soft key along the right side of the display.
3. Select the Equipment Setup tab along the top of the display.
4. Use the next button to access the Section Auto-Operation Times page.

5. This page allows the operator to adjust the section recirculation times for the specific application system or current chemical suspension.

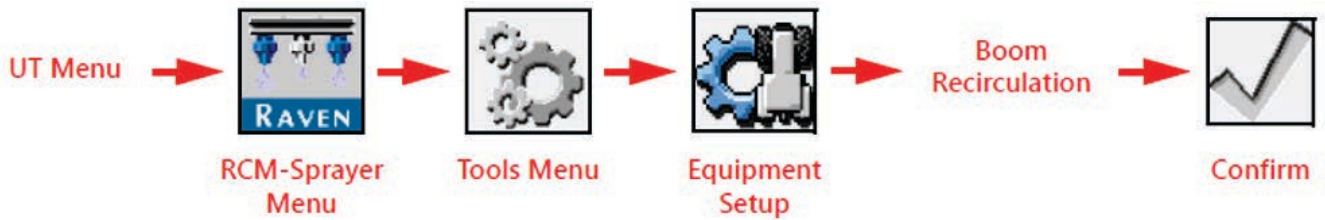

What To Expect While Recirculation Is Active

NOTE: When operating in Auto Recirculation Mode, it is recommended to adjust the Standby PWM% value so that recirculation pressure is close to the application pressure used during application.

When recirculation is active:

- Nozzle Control Valves (NCVs) will remain off.
- The main product pump runs at the “Standby PWM%” value.
- Section valves will cycle “On” sequentially in pairs from the outermost to innermost sections for the user defined recirculation time.
- The system will continue to monitor the main flow meter to ensure product is circulating. If the product recirculation is less than the low limit of the flow meter, the system will display an alert, but recirculation will continue.
- The boom pressure transducer is monitored to ensure the system pressure stays within the minimum and maximum allowable pressures. The main product pump will shut down if the boom pressure exceeds the minimum (2 PSI) or maximum (150 PSI) pressure.
- Section valves will continue to cycle sequentially unless spraying or shutdown conditions are met.
- The drain valve will be used to drain out any product in the recirculation line when rinsing the boom.

See Raven operation manuals for more information.

Setup (CapstanAg PinPoint III Boom Recirculation Specific)

To enable boom recirculation:

Tap Wrench > Pressure > Pump Setup > 2nd Page

Option 13: Recirculation

- OFF - Boom Recirculation will be inactive
- MANUAL - Manually turn on recirculation. Recirculation will turn off automatically when sections turn on
- AUTO - Recirculation automatically turns on when all sections are off
- AUTO DELAY 30s - Automatically turns on after all sections have been off for 30 seconds

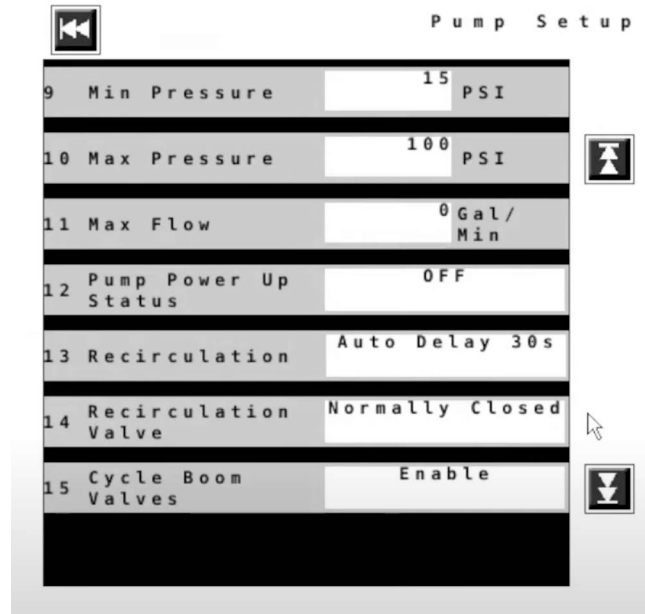

Option 14: Recirculation Valve - Ensure this is set to "Normally Closed".

See CapstanAg Operation manual for more information.

Setup (AgLeader Rightspot Boom Recirculation Specific)

Boom Recirculation Checkbox

To enable Boom Recirculation on the RightSpot Toolbox, check the box.

NOTE: The sprayer must be equipped with boom recirculation plumbing.

Recirculation Start Delay

Set the amount of time to delay recirculation after the system has entered standby mode. When the system enters standby mode, the Start Delay Criteria begins. Once that time has been reached, the boom recirculation will begin.

Section Valves Duration

Enter the amount of time each valve is open during the boom recirculation process.

NOTE: The sprayer must be equipped with boom recirculation plumbing.

To avoid application delays and erratic rates, the user should disable boom recirculation before starting to apply.

See the AgLeader Operation manual for more information.

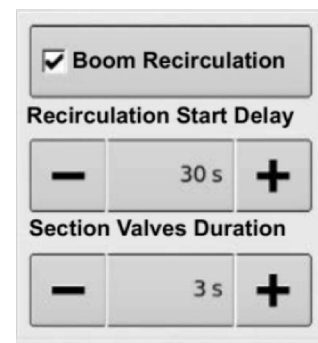

APACHE™

CHAPTER 5 LUBRICATION AND MAINTENANCE

The Scheduled Maintenance Icon will illuminate when maintenance is required.

Before performing any maintenance procedures, read the Safety Section on page 2-1.

Maintenance Precautions

- Parts found defective during inspection or any part whose specifications are not adequate must be replaced.
- ALWAYS tighten components to the specified torque. Loose parts can cause equipment damage or cause it to operate improperly.
- Only use Apache-approved replacement parts. Other replacement parts may affect warranty coverage.
- NEVER attempt to modify the Apache Sprayer design or safety features.
- If a warning alarm or indicator activates during engine operation, stop the Apache Sprayer and engine immediately and contact your Apache dealer. Determine the cause and repair the problem before continuing operation. To ensure your safety, the safety of others, and the safe operation and maintenance of the sprayer, read, follow, and practice the following:



WARNING! Exposure Hazards

- **ALWAYS wear appropriate eye protection to prevent the risk of eye injury. Wear safety glasses to prevent eye contact with debris, chemicals and fluids.**
- **ALWAYS wear ear plugs when working around loud noises to prevent hearing loss.**
- **ALWAYS wear the appropriate gloves to protect your hands, especially when handling extremely hot or cold equipment and fluids.**



WARNING! Entanglement Hazards

- **ALWAYS attach a “Person working on vehicle. DO NOT Start or Operate” tag near the key switch while performing maintenance on the equipment.**
- **ALWAYS stop the engine before beginning service.**
- **NEVER operate the engine without the guards in place.**
- **ALWAYS remove any tools or shop rags used during maintenance from the area before operation.**
- **NEVER engage the transmission or driven equipment by hand from underneath the Apache Sprayer when the engine is running.**



WARNING! Piercing Hazards

- **Avoid skin contact with high-pressure diesel fuel spray caused by a fuel system leak such as a broken fuel injection line. High-pressure fuel can penetrate your skin and result in serious injury. If you are exposed to high-pressure fuel spray, obtain prompt medical treatment.**
- **NEVER check for a hydraulic leak with your hands. ALWAYS use a piece of wood or cardboard.**

**WARNING! Flying Object Hazard.**

- **ALWAYS** wear eye protection when servicing the engine or when using compressed air or high-pressure water. Dust, flying debris, compressed air, pressurized water or steam may injure your eyes.

**WARNING! Crush Hazards**

- **ALWAYS** make sure the Apache Sprayer is on flat, solid ground before getting under the Apache Sprayer.
- **ALWAYS** block front and rear axle wheels before getting under the Apache Sprayer.
- If using a hydraulic jack or jack stands, ensure they are of the proper capacity and used in a proper manner under the frame of the Apache Sprayer.
- Use a hoist or use assistance when lifting components that weigh 50 lb [23 kg] or more. Make sure all lifting devices such as chains, hooks or slings are in good condition, of the correct capacity, positioned correctly and have current, valid inspection labels.
- **ALWAYS** use lifting equipment with sufficient capacity to lift the Apache Sprayer or equipment.
- If transport is needed for repair, acquire assistance when using a hoist and when loading and unloading.

**WARNING! Fire/Explosion Hazards**

- While the engine is running or the battery is charging, hydrogen gas is being produced and can be easily ignited. Keep the area around the battery well-ventilated and keep sparks, open flame and any other form of ignition out of the area.
- **ALWAYS** turn off the battery switch or disconnect the negative (-) battery cable before servicing the equipment

**WARNING! Explosion Hazard.**

- Batteries contain sulfuric acid. **NEVER** allow battery fluid to come in contact with clothing, skin or eyes. Severe burns could result. If battery fluid contacts the eyes and/ or skin, immediately flush the affected areas with a large amount of clean water and obtain prompt medical treatment.

**WARNING! Exposure Hazard.**

- **ALWAYS** wear safety goggles and protective clothing when servicing the battery.

**WARNING! High-Pressure Compressed Air - Exposure and Impact Hazards**

- Pneumatic components store compressed air and can separate violently during disassembly or removal. Before servicing any part of the pneumatic (air) system, slowly release all compressed air from the system.
- **NEVER** exceed the recommended working air pressure.
- **NEVER** connect or disconnect a hose or line containing air pressure.
- **ALWAYS** wear safety glasses when working with compressed air systems. **NEVER** look into the area of escaping air when draining air tanks or disconnecting lines. Dirt or moisture may be expelled, causing eye injury.

**WARNING! Shop Equipment Hazards**

- **ALWAYS check before starting the engine that any tools or shop rags used during maintenance have been removed from the area.**
- **ALWAYS use tools appropriate for the task at hand and use the correct size tool for loosening or tightening machine parts.**
- **ALWAYS use the proper tools and equipment for servicing the Apache Sprayer. Ensure the tools are rated and approved for use with this Apache Sprayer.**
- **If an Apache Sprayer is to be operated with test equipment connected, precautions must be taken to ensure that all equipment and related components are securely attached to prevent movement and interference.**
- **Before performing any maintenance procedure, have all the correct tools you need to perform the required tasks.**
- **Ensure that the work area is adequately illuminated. ALWAYS install wire cages on portable safety lamps.**

Environmental Precautions

The safety messages that follow have NOTICE level hazards.

- Thoroughly clean any spilled fluids from the equipment and/or ground after service is completed. Dispose of used fluids and filters as required by law.
- ALWAYS be environmentally responsible. Follow the guidelines of the EPA or other governmental agencies for the proper disposal of hazardous materials such as engine oil, diesel fuel and engine coolant. Consult the local authorities or reclamation facility.
- NEVER dispose of hazardous materials by dumping them into a sewer, on the ground, or into ground water or waterways.

Non-Apache Equipment Maintenance

Some components and systems of Apache Sprayers are manufactured by companies other than Apache and have specific safety, inspection, adjustment and maintenance procedures outlined by their manufacturer.

NOTICE: ALWAYS perform maintenance procedures for all OEM equipment in addition to procedures for the Apache Sprayer.

Some non-Apache equipment operator's and maintenance manuals are included with the Apache Sprayer. These include, but are not limited to, the Engine Owner's Manual, Sprayer Monitor System Manual, Chemical Educator Manual, Product Pump Instructions and other optional equipment manuals.

NOTICE: ALWAYS perform and reference the original equipment manufacturers' service information when performing service or maintenance procedures on equipment manufactured by companies other than Apache. Before servicing original equipment manufacturer (OEM) systems or components, properly identify the OEM model and serial number to ensure correct service and replacement part information is referenced.

Cleaning Guidelines

The following guidelines are recommended when cleaning mechanical and electrical parts of the cab.



WARNING! Fire Hazard

- *Cleaning solvents can cause death or serious injury.*
- *Cleaning solvents are extremely flammable and toxic if inhaled.*
- *DO NOT use near sparks or flame and avoid inhaling.*
- *Use in a well-ventilated area and follow the manufacturers' warnings on use and handling.*



WARNING! Exposure Hazard.

- *Wear safety glasses, gloves, and other proper protective clothing or gear when handling part cleaners or other hazardous cleaning agents.*

The safety messages that follow have *NOTICE* level hazards.

- Use caution when using power washers to avoid damaging rubber, plastic or electrical components.

Mechanical Parts

- Clean mechanical parts with a noncombustible cleaning agent.
- Clean mating surfaces thoroughly after removing a part to which an O-ring or gasket is attached. If you replace a part, ALWAYS use a new O-ring or gasket.

Electrical Parts

- NEVER spray water or cleaners directly on electrical parts.
- Electrical parts are susceptible to water damage and insulations leaks. Current leakage can develop if electrical parts become wet or the insulation is damaged.

Body and Cab Exterior

- The use of a low-pressure water supply system and mild automotive-type soap is recommended to wash and rinse the Apache Sprayer.
- DO NOT use abrasive cleaning materials on the Apache Sprayer, as brushes, chemicals and cleaners may damage the finish or components.
- DO NOT remove ice or snow from painted surfaces with a scraper or blade.
- DO NOT allow diesel fuel, oils, lubricants or antifreeze to come in contact with painted surfaces.
- When cleaning chrome, stainless-steel or aluminum parts, use clean water and a soft cloth.
- Avoid scratching or damaging polished metal finishes; DO NOT use abrasive cleaners.
- NEVER use pressurized water or cleaners to clean the cab interior.
- NEVER use corrosive cleaning solutions or any type of abrasives. Part or equipment damage caused by use of corrosive cleaners or abrasives is not covered under Apache warranty.
- Periodically clean the interior dash, gauge panels, floor and seat with a mild cleanser or water-dampened cloth.
- Periodically clean all interior glass with a water-dampened cloth or approved glass cleaning materials.

Apache Sprayer Service Interval Chart

Perform and repeat the prescribed maintenance at each interval. ▲ = Conditional Service ● = Regular Service ○ = Required 100 Hour Service NOTE: DO NOT overlook the "After First 100 Hours" interval.	Before Initial Use	After First 10 Hours	As Required	Daily	Every 40 Hours	After First 100 Hours	Every 100 Hours	Every 250 Hours or Yearly	Every 500 Hours or Yearly	Every Year	Every 1000 Hours or Yearly	Every 2000 Hours or Yearly	Every 4500 Hours or 3 Years
Grease Boom	○			●									
Grease Boom Fold Cylinders	○			●									
Adjust Poly Tank Straps	○	○			●								
Torque Lug Nuts	○	○			●								
Grease Driveline Components	○						●						
Adjust Boom	○	○	○										
Clean Primary Engine Air Filter			○					●					
Change Primary Engine Air Filter								●					
Change Engine Safety Air Filter			○							●			
Adjust Toe-In			○							●			
Winterize Wet System										●			
Flush Wet System (including product pump)			○	●									
Check Tire Pressure				●									
Check Oil Engine Level				●									
Drain Water from Primary Fuel Filter				●									
Check Coolant Level, Cooling Package, and Hoses				●									
Check Transmission Fluid Level				●									
Check Hydraulic Fluid Level				●									
Grease King-pins					●								
Check Differential Fluid Level					●								
Check Differential for Leaks					●								
Check Final Drive Fluid Level					●								
Check Final Drives for Leaks					●								
Torque Rear Axle Lower Torque Arm Mount Bolts						▲	●						
Change Differential Fluid						▲		●					
Change Hydraulic Fluid Filter (Immediately if indicated by console screen)						▲		●					
Change Primary Fuel Filter						▲			●				
Change Secondary Fuel Filter						▲			●				
Change Engine Oil and Filter						▲			●				
Change Transmission Fluid and Filter						▲			●				
Change Final Drive Fluid (drop box)						▲			●				
Change Cab Filter (charcoal filter)									●				
Inspect and Repack Wheel Hub Bearings									●				
Change Hydraulic Fluid										●			
Change DEF Tank Strainer										●			
Change Crankcase Ventilation Filter											●		
Change DEF Supply Module Filter													●

Before Initial Use

The following services must be performed before initial use of the Apache Sprayer and repeated at the interval prescribed in the Apache Sprayer Service Interval Chart. See “Apache Sprayer Service Interval Chart” on page 5-5.

- Torque Lug Nuts. See “Torque Lug Nuts” on page 5-16.
- Grease Boom. See “Grease Boom” on page 5-10.
- Grease Driveline. See “Grease Driveline Components” on page 5-18.
- Adjust Poly Tank Straps. See “Adjust Poly Tank Straps” on page 5-16.
- Adjust Boom. See “Adjust Boom” on page 5-6.

After First 10 Hours

The following services must be performed after the first 10 hours of operation and repeated at the interval prescribed in the Apache Sprayer Service Interval Chart. See “Apache Sprayer Service Interval Chart” on page 5-5.

- Torque Lug Nuts. See “Torque Lug Nuts” on page 5-16.
- Adjust Poly Tank Straps. See “Adjust Poly Tank Straps” on page 5-16.

Adjust Boom

NOTICE: All boom adjustments should be performed with the boom fully unfolded and lowered.

Boom Lead Adjustment

1. Unfold the boom wings and boom tips, then lower the back rack.
2. Loosen the 3 bleed screws (1) for the boom fold and cushion circuits.

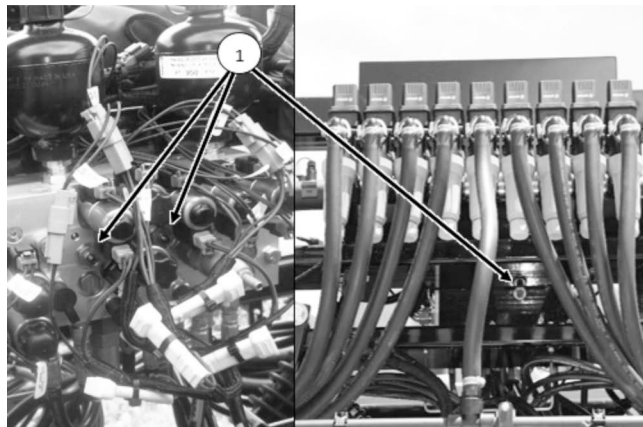

3. Loosen the jam nut (1) on the fold cylinder cushion rod.
4. Rotate the fold cylinder cushion rod (2) to adjust the boom lead. Decreasing the number of visible threads on the fold cylinder clevis will reduce the boom lead. Increasing the number of visible threads on the fold cylinder clevis will increase the boom lead.
5. After adjusting the boom lead so that the tips are even with the back rack, tighten the jam nuts (1).

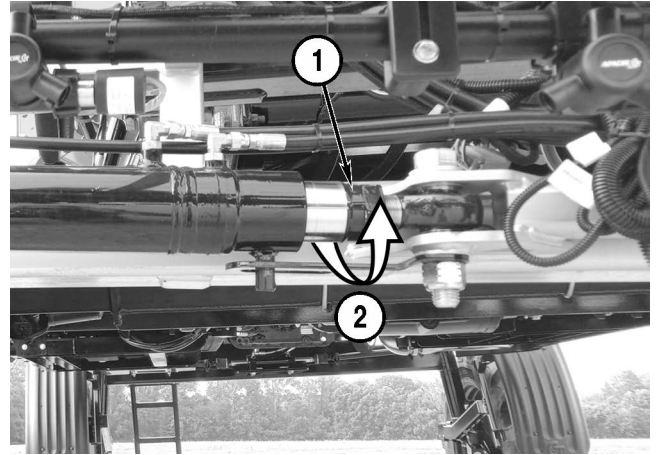

6. Tighten the three bleed screws (1) and their jam nuts.

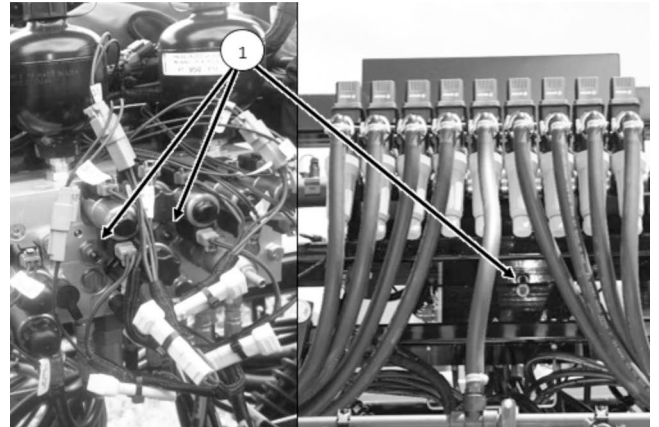

7. To check the boom lead adjustments, raise the back rack and fold the booms all the way in. Then repeat the unfold process and recheck the boom lead. Readjust if needed.



Boom Stabilizer

There are two boom stabilizers mounted on the boom rack. The left-side stabilizers (1) are shown.

The gap between the nylon wear pads and the steel frame should be 0.039 to 0.079 in. [1 to 2 mm] with the booms unfolded.

To adjust the gap:

1. Loosen both lock nuts (2) on the stabilizer and equally adjust the jam nuts (3) until the gap is correct.
2. Tighten the lock nuts (2).
3. Repeat the steps for the other stabilizers, as required.

NOTE: For best performance, the jam nuts must be adjusted so the stabilizer halves are parallel and provide the 0.039 to 0.079 in. [1 to 2 mm] gap.

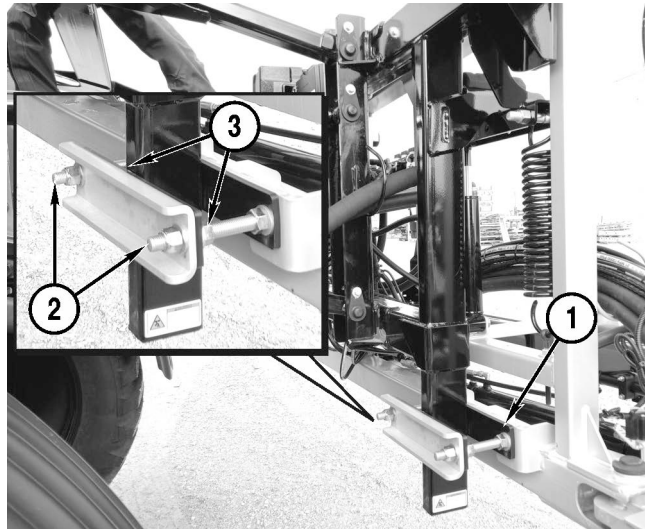

As Required

The following services will be required at various intervals depending on Apache Sprayer use and environmental conditions. Repeat these services as prescribed by the Apache Sprayer Service Interval Chart. See “Apache Sprayer Service Interval Chart” on page 5-5.

- Adjust Boom. See “Adjust Boom” on page 5-6.
- Adjust Toe-In. See “Adjust Toe-In” on page 5-28.
- Clean the Primary Engine Air Filter. See “Clean or Change Engine Primary Air Filter” on page 5-20.
- Change Engine Safety Air Filter. See “Change Engine Safety Air Filter” on page 5-29.

NOTICE: When operating in severe conditions, the primary air filter should be cleaned after every 40 hours of use or if indicated by the console display. Filter usage should not exceed 250 hours.

- Flush Wet System. See “Flushing Booms” on page 4-18.

Daily

The following services must be performed daily, before operation of the Apache Sprayer.

NOTICE: NEVER clean the inner engine air filter (engine safety air filter). When it is dirty, ALWAYS replace it with a new one.

Grease Boom

(Optional Equipment)

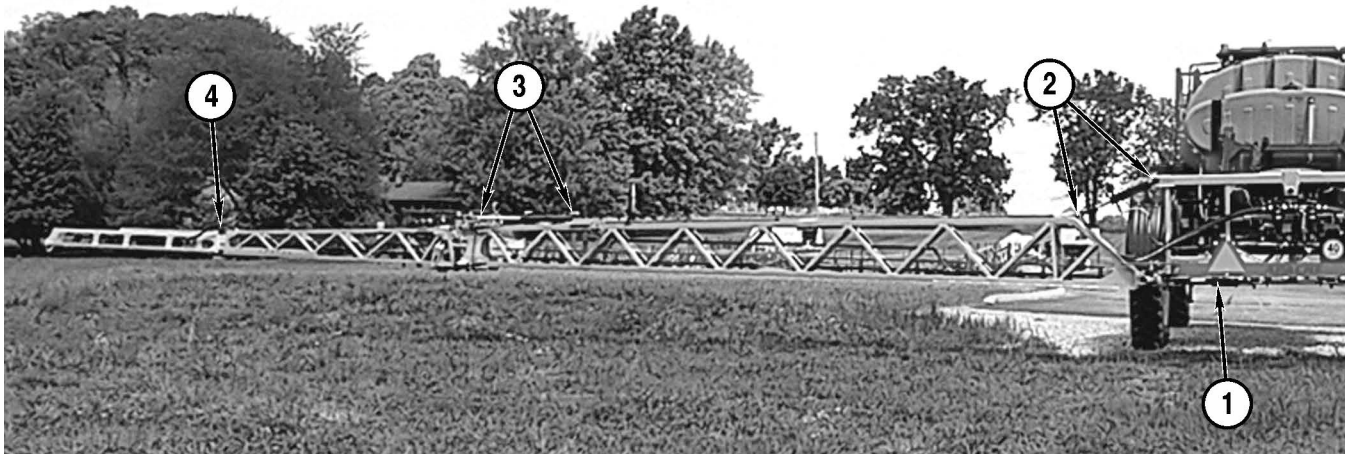

The boom is equipped with four sets of grease fittings. Apply an ample amount of lithium grease through each of the grease fittings.

- | | |
|---|---|
| <ol style="list-style-type: none"> 1. Boom Fold Cylinder <ul style="list-style-type: none"> • 2 fittings 2. Tilt Cylinder <ul style="list-style-type: none"> • 2 fittings | <ol style="list-style-type: none"> 3. Boom Tip Fold <ul style="list-style-type: none"> • 7 fittings [aluminum] • 8 fittings [steel] 4. Boom Breakaway <ul style="list-style-type: none"> • 1 fitting |
|---|---|

Boom Fold Cylinder

There are two grease fittings (1) on each boom fold cylinder. The left side is shown.

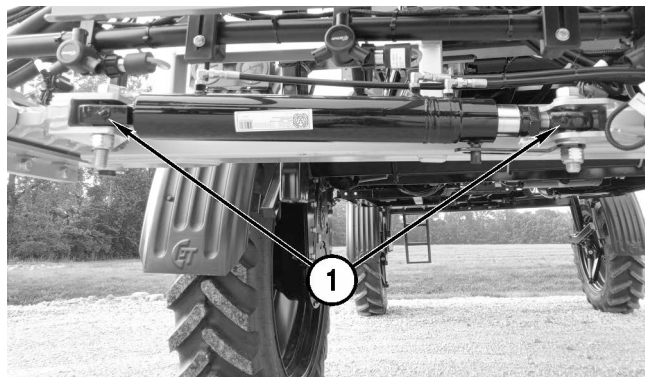

Tilt Cylinder

There are two grease fittings (1) on each tilt cylinder. The left side is shown.

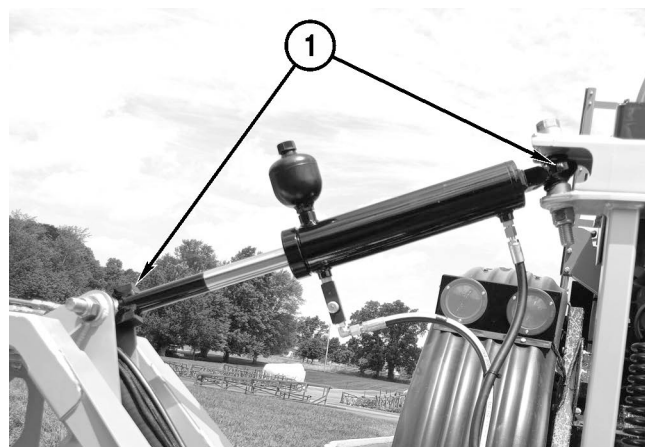

Boom Tip Fold

There are seven aluminum (upper image) or eight steel grease fittings (lower image) in the boom tip fold area of each boom. The left side is shown.

NOTE: The booms must be placed in the open position to access some fittings and in the folded position to access the remaining fittings.

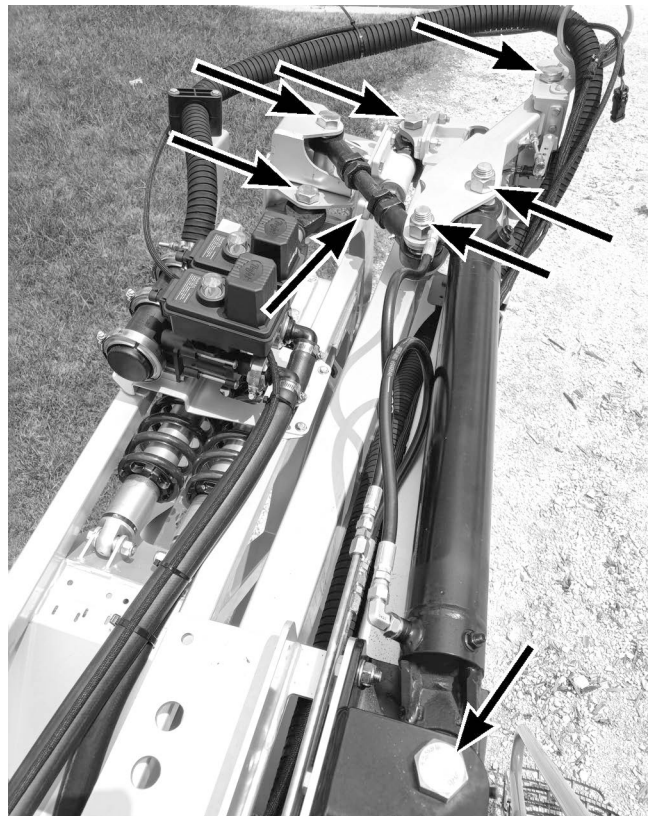
**Boom Breakaway**

There is one grease fitting (1) on each boom breakaway. The left side is shown.

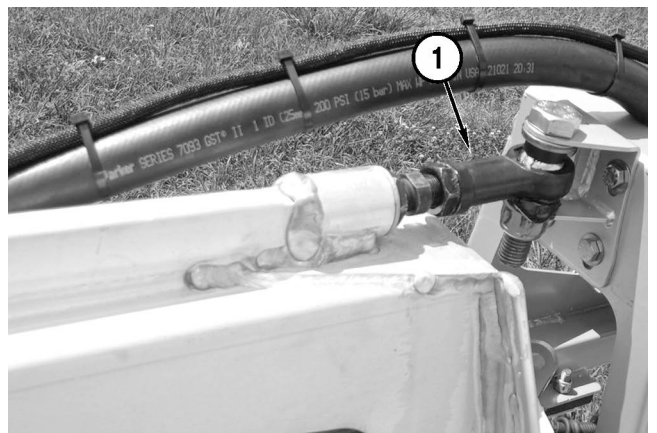

Flush Wet System

Drain and flush the product tank and wet system after use and when changing chemicals. See “Flushing Product Tank” on page 4-17. See “Flushing Booms” on page 4-18.

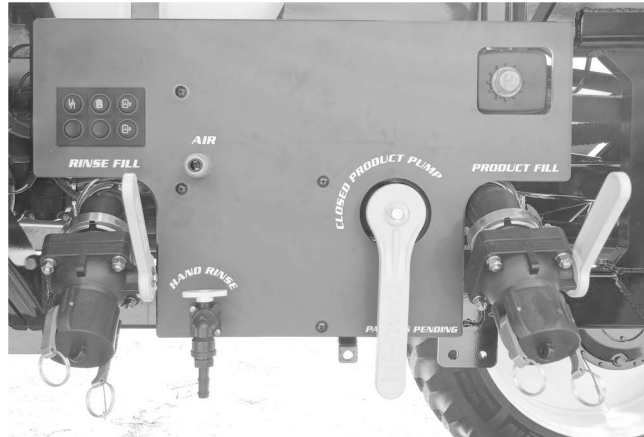

Check Tire Pressure

Perform the following:

- Check the tires for damage. Replace tires that have cuts or bubbles.
- Check the tires for proper inflation pressure. Inflate tires according to the tire manufacturer's recommendations. See “Apache AS650 Fluids, Filters and Capacities” on page 1-2.
- Check the rims for cracks and other damage. Replace damaged rims.



Check Engine Oil Level

NOTICE: If the engine has been running, shut off and wait 10 minutes before checking oil level.

The dipstick (1) is located in the engine compartment, on the left side of the engine.

While parked on level ground, remove the dipstick and check the oil level.

The oil level should be within the hatched area on the dipstick.

If the oil level is below the ADD mark, add high quality Lucas 15W-40 Magnum motor oil at the oil fill location (2) on top of the engine.

Add oil as needed to bring the level to the hatched area on the dipstick.

Replace the dipstick.

Additional lubricating oil system information is available in the engine manufacturer's manual provided with the Apache Sprayer.

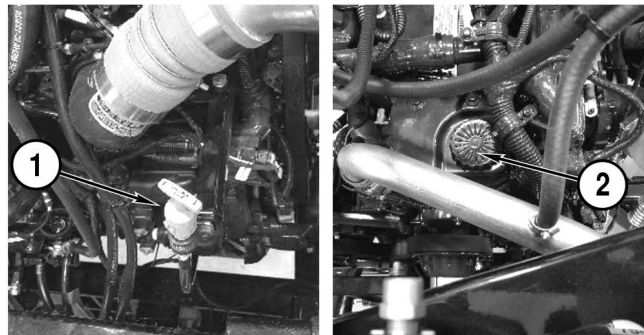

Check Cooling System



WARNING! Fire Hazard. Coolant may be flammable under certain conditions. NEVER allow coolant to come into contact with hot surfaces.



WARNING! Exposure Hazard. Wear eye protection and rubber gloves when handling engine coolant. Avoid skin contact with coolant. If contact with the eyes or skin should occur, flush eyes and wash immediately with clean water.



WARNING! Burn Hazard. NEVER remove the radiator cap if the engine is hot. Steam and hot engine coolant will spray out and seriously burn you. Allow the engine to cool down before you attempt to remove the cap.

Remove the radiator cap and check the coolant level. Remove the radiator cap slowly to relieve internal pressure. The coolant should be level with the bottom of the fill neck.

Add coolant as necessary. DO NOT overfill the cooling system, as this may cause the coolant to spray from the system during operation.

NOTICE: See the engine manufacturer's manual for coolant requirements and additional cooling system information. Coolant specifications must meet or exceed ASTM D3306 / D6210 or RP-329.

Install the radiator cap.



WARNING! Burn Hazard.

ALWAYS tighten the radiator cap securely after checking the coolant. Steam can spray out during engine operation if the cap is loose.

Inspect the cooling system components for damage and debris.

- Check tubes, hoses and other components for damage and leaks.
- Replace damaged components as necessary.
- Clean debris from around or between cooling package components.

Check Transmission Oil Level

NOTICE: While parked on level ground, check the transmission fluid level with the oil at operating temperature and the engine off.

The transmission fluid dipstick is located in the engine compartment, on the left side of the engine, and toward the cab.

NOTE: The transmission fluid should be at operating temperature and the engine should be off.

Turn the dipstick handle counterclockwise to loosen.

Remove the dipstick and check the transmission fluid level.

The fluid level should be between the two dots on the dipstick.

NOTICE: DO NOT overfill the transmission fluid. Overfilling can damage the transmission or cause the transmission to malfunction or overheat.

NOTICE: Use only Lucas Universal Hydraulic Fluid or equivalent.

If the fluid level is below the lower dot on the dipstick, use a funnel to add fluid through the dipstick tube.

Add Lucas Universal Hydraulic Fluid, or equivalent, to bring the level between the dots on the dipstick.

Replace the dipstick and turn the handle clockwise to tighten.

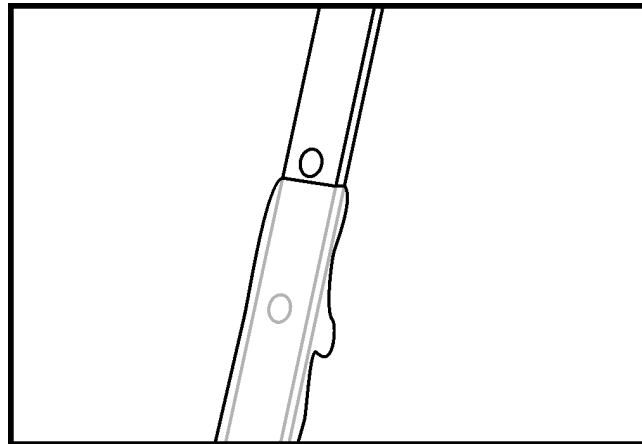
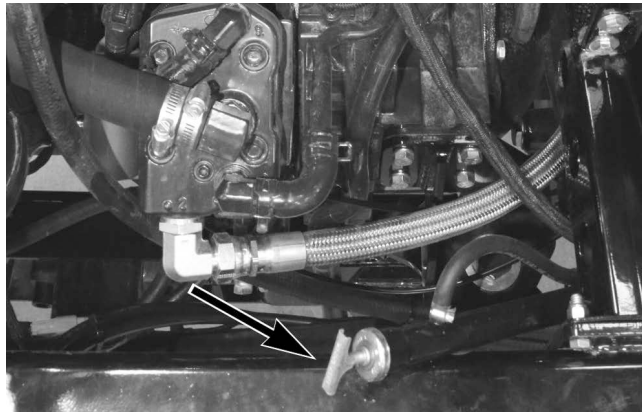

Check Hydraulic Fluid Level

NOTICE: The machine must be on level ground with the booms folded and in the transport position for an accurate hydraulic fluid level reading.

The hydraulic fluid reservoir is located on the right side of the Apache Sprayer and a sight glass (1) indicates the hydraulic fluid level.

NOTICE: Use only Lucas Universal Hydraulic Fluid, or equivalent, for the Apache Sprayer hydraulic system.

If no fluid is visible in the sight glass, remove the fill cap and add Lucas Universal Hydraulic Fluid, or equivalent, until fluid is visible in the bottom of the sight glass.

NOTICE: Oil should be topped off after the oil in reservoir is at operating temperature to avoid overfill. DO NOT fill more than 3/4 up on the sight glass.

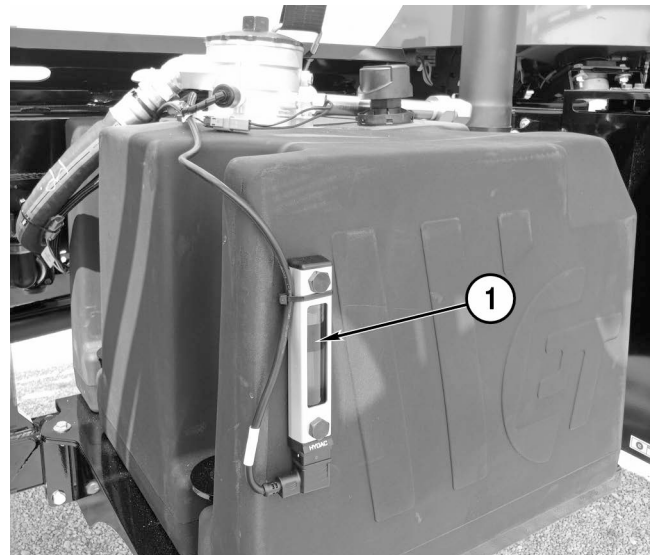

Drain Primary Fuel Filter

Drain the water from the primary fuel filter by opening the valve (1).

Close the valve after draining.

Use the priming pump (2) to prime the filter.

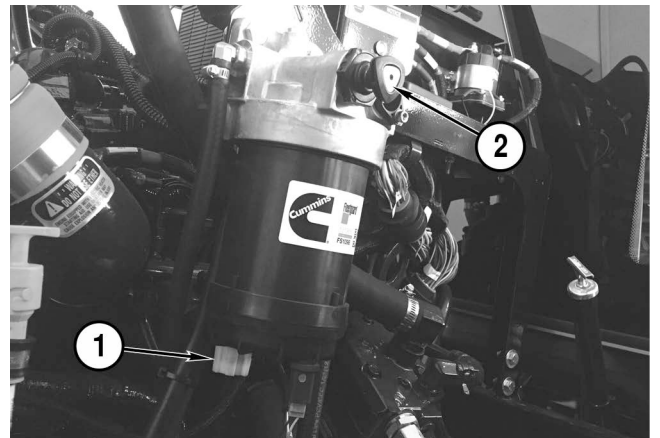

Every 40 Hours

The following services must be performed after every 40 hours of operation of the Apache Sprayer.

Adjust Poly Tank Straps

Check the poly tank straps while the tank is at least 50% full. If the straps feel or appear loose, tighten them evenly from side to side without deforming the tank, the bolts or the tank cradle.



Torque Lug Nuts

Torque wheel lug nuts to:

- 420 lb-ft [569 N•m]



Grease King-pins

Each axle arm has two king-pin grease fittings (1), one inter-flex bearing grease fitting (2), and one hub grease fitting (3). The right wheel is shown.

Apply lithium grease through the two king-pin grease fittings (1).

NOTE: The inter-flex (2) and hub (3) bearing are sealed chambers and once greased require very little grease to maintain.

Apply lithium grease through the inter-flex bearing grease fitting (2).

Apply lithium grease through the hub bearing grease fitting (3).

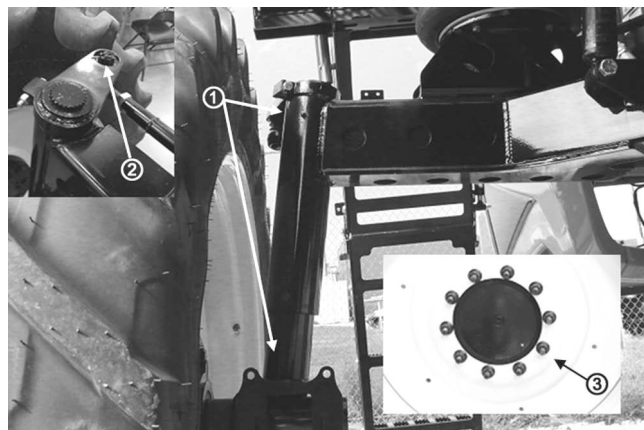

Check Differential Fluid Level

The differential is located under the Apache Sprayer, on the rear axle. The fill/level plug is directly above the drain plug on the rear of the differential.

With the machine parked on level ground, remove the differential fill/level plug (1) and check the fluid level. The fluid should be level with the bottom of the fill/level hole.

Install the plug and tighten.

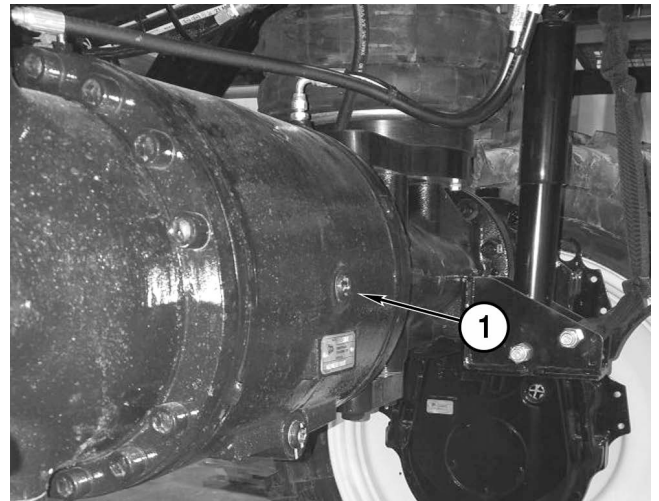

Check Rear Differential for Leaks

Inspect the differential for leaks at the U-joint, near the drop boxes, and between inner and outer housings. Repair the leaks before operating the Apache Sprayer.

Check Final Drive Fluid Level

Drop Box

The drop box level plug (1) is located on the drop box at each rear wheel. The left drop box is shown.

Remove the drop box level plug (1). The fluid level should be at the bottom of the level hole. If the fluid level is good, install and tighten the level plug (1).

NOTICE: Use only Lucas 80/90 Gear Oil or equivalent for the drop box fluid.

If the fluid level is low, remove the drop box fill plug (2) and add fluid until it is level with the bottom of the level hole (1).

NOTE: Drop Box Fluid Capacity: Approximately 21 quarts [20 liters]

Install and tighten the fill plug (2) and the level plug (1).

Repeat the steps for the other drop box.

Check Drop Box for Leaks

Inspect the drop box for leaks around the housing and around the three plugs.

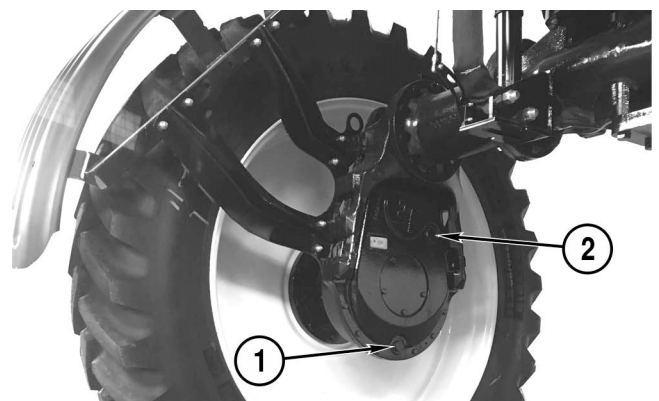

After First 100 Hours

The following services must be performed after the first 100 hours of operation and repeated as prescribed by the Apache Sprayer Service Interval Chart.

- Change Primary Fuel Filter. See “Change Primary Fuel Filter” on page 5-23.
- Change Secondary Fuel Filter. See “Change Secondary Fuel Filter” on page 5-23.
- Change Differential Fluid. See “Change Differential Fluid” on page 5-21.
- Change Hydraulic Fluid Filter. See “Change Hydraulic Fluid Filter” on page 5-21.
- Change Engine Oil and Filter. See “Change Engine Oil and Filter” on page 5-24.
- Change Transmission Oil and Filter. See “Change Transmission Oil and Filter and Clean Strainer” on page 5-25.
- Check torque on rear axle torque arm mount plate bolts. See “Check Torque on Rear Axle Lower Torque Arm Mounting Plate Bolts” on page 5-19.
- Change Final Drive Fluid. See “Change Final Drive Fluid” on page 5-26.

Every 100 Hours

The following services must be performed after every 100 hours of operation of the Apache Sprayer.

Grease Driveline Components

The Apache Sprayer has a total of four driveline grease fittings. One at the output of the transmission u-joint. One at the input of the differential and two at the slip joint area.

Apply an ample amount of Lucas lithium grease or equivalent through each of the fittings.

One slip joint grease fitting (1) is located under the Apache Sprayer, between the transmission and the rear axle.

A U-joint fitting is located at the transmission output U-joint (not shown) and another fitting (2) is located on the U-joint connected to the slip joint.

A U-joint fitting (1) is located at the differential input.

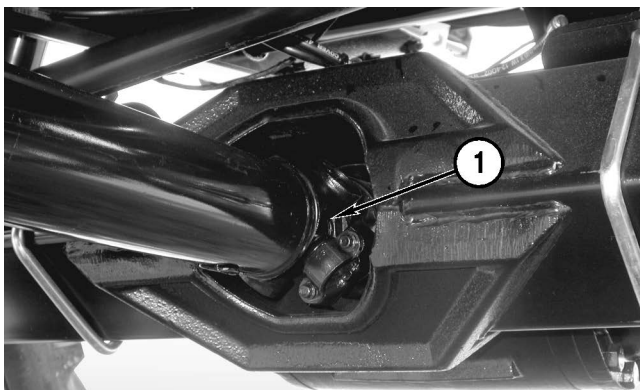
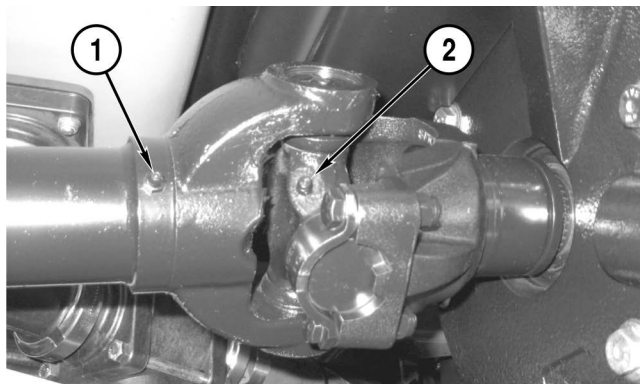

Check Torque on Rear Axle Lower Torque Arm Mounting Plate Bolts

Locate the two lower torque arm mounting plates on the bottom of the rear axle. There are 4 bolts on each plate (1).

Torque each bolt to 220 ft-lbs.

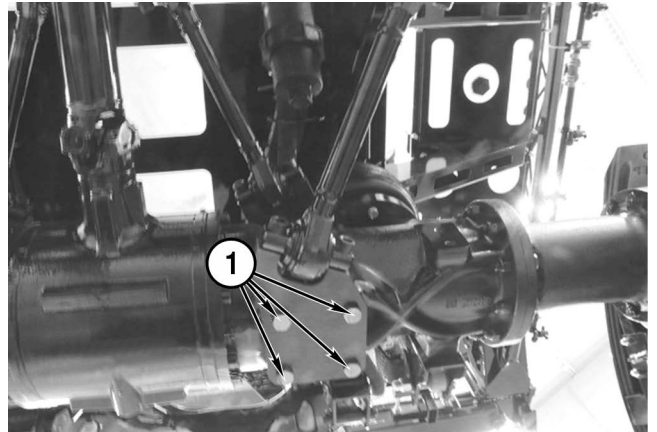

Every 250 Hours or Yearly

NOTE: Some services at this interval were performed at the “After First 100 Hours” interval. If the service was performed as prescribed, measurement of 500 hours should begin at the 100 hour mark.

The following services must be performed after every 250 hours of operation or yearly.

Clean or Change Engine Primary Air Filter

NOTICE: When operating in severe conditions, the primary air filter should be cleaned if indicated by the console display.

NOTICE: If a “Change Air Filter” fault is indicated on the touch screen display, stop immediately and remove and clean or replace the primary air filter as needed.

The primary air filter is mounted in the engine compartment, above the engine and toward the cab.

Clean the outside of the air cleaner assembly.

Release the four latches (1) and remove the cover (2) from the air cleaner assembly.

NOTICE: NEVER clean the inner engine air filter (engine safety air filter). When it is dirty, ALWAYS replace it with a new one.

Use the pull tabs (2) to remove the engine safety air filter.

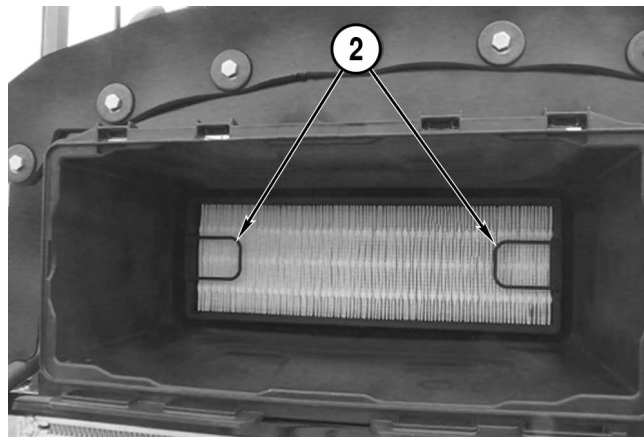
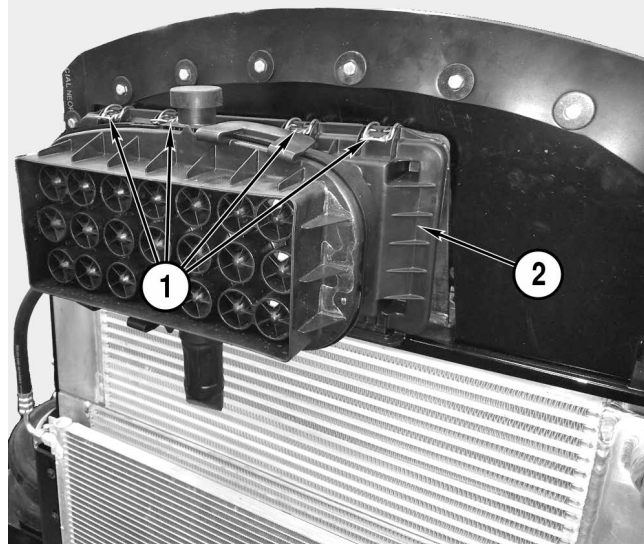

Use a rocking motion to release the primary air filter (1) from the assembly.

Clean the filter using compressed air. Blow the filter from the inside-out.

If installing a new primary engine air filter:

- Primary Engine Air Filter Part Number: 201300140.

Install the filter, the air cleaner cover, and engage the cover latches.

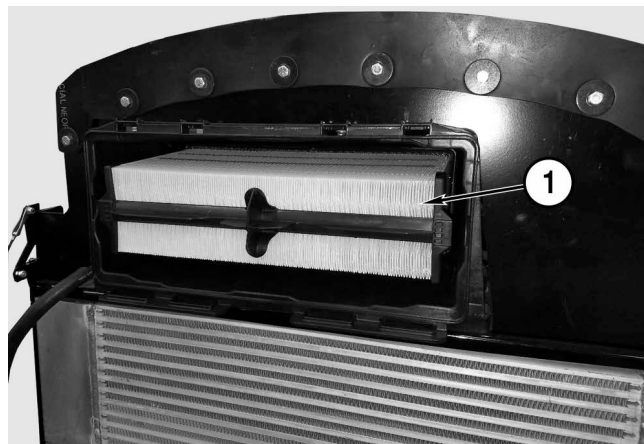

Change Differential Fluid

The differential is located under the Apache Sprayer, on the rear axle. The fill/level plug (1) is directly above the drain plug on the rear of the differential.

Remove the differential drain plug and drain the fluid into a suitable container. Dispose of the fluid properly.

Install the drain plug and tighten.

NOTICE: Use only Lucas Universal Hydraulic Fluid, or equivalent, for the differential fluid.

Remove the differential fill/level plug (1). Add fluid until it is level with the bottom of the fill/level hole.

- Differential Fluid Capacity:
 - 90" Axle: 3.5 gallons [13.2 liters]
 - 108"/114" Axle: 4.3 gallons [16.3 liters]
 - 120" Axle: 5.5 gallons [20.8 liters]

Install the fill/level plug (1) and tighten.



Change Hydraulic Fluid Filter

The hydraulic fluid filter is located between the cab and product tank on the right side of the Apache Sprayer.

Remove the cover (1) from the filter housing.

Remove the filter from the assembly.

Discard the filter into an appropriate container.

Install an o-ring on the filter housing and lubricate it with clean Lucas Universal Hydraulic Fluid or equivalent.

Install the filter into the filter housing.

Install and tighten the filter housing cover.

Use the sight glass to check the fluid level. See "Check Hydraulic Fluid Level" on page 5-15.

NOTICE: Use only Lucas Universal Hydraulic Fluid, or equivalent, for the Apache Sprayer hydraulic system.

NOTE: Fill the reservoir slowly to reduce the possibility of spilling.

Fill the hydraulic fluid reservoir with Lucas universal Hydraulic Fluid or equivalent. The reservoir capacity is approximately 23 gallons [87 liters].

REMINDER: Fluid level should be checked with hydraulic oil at operating temperature to avoid overfilling.



Use the sight glass (1) to check the fluid level. See “Check Hydraulic Fluid Level” on page 5-15.

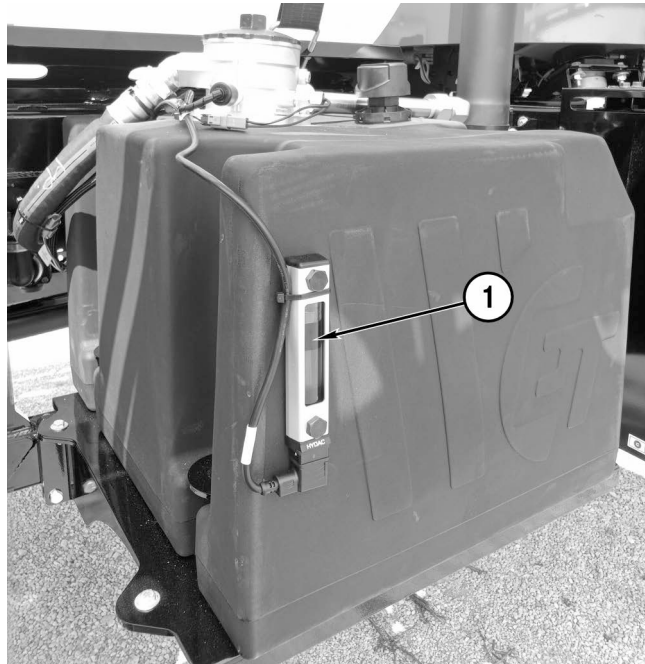

Every 500 Hours or Yearly

Change Primary Fuel Filter

The fuel filter (1) is located in the engine compartment on the left side of the engine.



WARNING! Fire Hazard. Wipe up fuel spills immediately. Fuel will spill from the filter and fuel lines when loosened or removed. Use a suitable container to collect the fuel and dispose of properly.

Turn the filter counterclockwise to remove. Dispose of the filter properly.

NOTICE: ALWAYS replace the fuel filter with a new fuel filter.

- Primary Fuel Filter Part Number: 211000000

Fill the new filter with diesel fuel before installing.

Tighten the filter, by hand, 3/4 to 1-1/4 turns after the seal contacts the filter housing.

NOTE: It is not necessary to bleed the fuel system after replacing fuel filters.

Additional fuel system information is available in the engine manufacturer's manual provided with the Apache Sprayer.

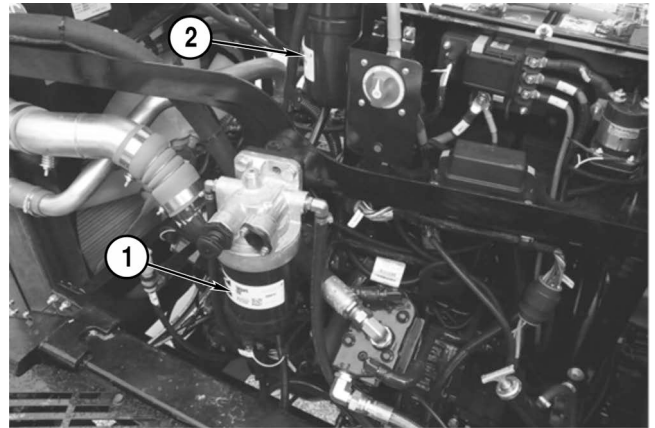

Change Secondary Fuel Filter

The secondary fuel filter (2) is located in the engine compartment on the left side of the engine.

Turn the filter counterclockwise to remove.

Dispose of the filter properly.

NOTICE: ALWAYS replace the secondary fuel filter with a new separator filter.

- Secondary Fuel Filter Part Number: 261000003.

Fill the new filter with diesel fuel before installing.

NOTICE: DO NOT over-tighten the filter. Damage to the seal can result.

Tighten the filter, by hand, 3/4 to 1-1/4 turns after the seal contacts the filter housing.

NOTE: It is not necessary to bleed the fuel system after replacing fuel filters.

Additional fuel system information is available in the engine manufacturer's manual provided with the Apache Sprayer.

Change Engine Oil and Filter



WARNING! Burn Hazard. If you must drain the engine oil while it is still hot, stay clear of the hot engine oil to avoid being burned. ALWAYS wear eye protection.

Operate the engine for approximately five minutes to warm the engine oil. Shut off the engine.

The engine oil drain plug is located on the bottom of the oil pan. Remove the engine oil drain plug and drain the oil into a suitable container. Properly dispose of the used engine oil.

Install the drain plug and tighten to the torque value below:

- 1.Plug with Copper Washer: 52 lb-ft [71 N•m]
- 2.Plug with O-ring: 37 lb-ft [50 N•m]

The engine oil filter is located on the right side of the engine.

Turn the engine oil filter counterclockwise to remove. Dispose of the filter properly.

NOTICE: DO NOT over-tighten the filter. Damage to the seal can result.

Lubricate the seal on the engine oil filter.

- Engine Oil Filter Part Number: 201450241.

Install and tighten the filter, by hand, 3/4 to 1-1/4 turns after the seal contacts the filter housing.

NOTICE: DO NOT overfill the engine oil. Crankcase oil capacity can vary. ALWAYS use the dipstick to determine if the engine oil is to the appropriate level.

Fill the engine with high quality Lucas 15W-40 Magnum motor oil or equivalent at the oil fill location (2) on the left side of the engine.

- Engine Oil Capacity:
Approximately 16 quarts [15 liters].

Add oil as needed to bring the level to the hatched area on the dipstick.

Install the dipstick (1).

Operate the engine and check for leaks.

Shut off the engine and wait 10 minutes. Check the engine oil level and add oil as needed to bring the level to the hatched area on the dipstick.

Additional lubricating oil system information is available in the engine manufacturer's manual provided with the Apache Sprayer.

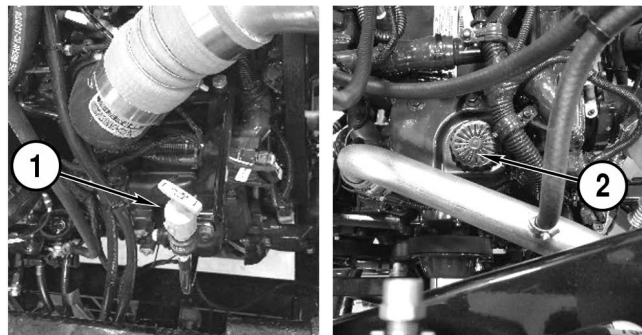
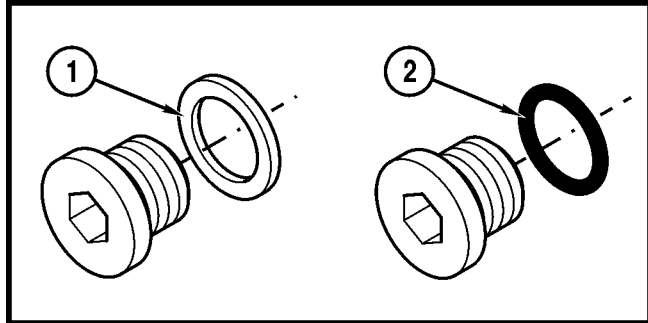

Change Transmission Oil and Filter and Clean Strainer

The transmission drain plug is located under the machine on the front side of the transmission.

Remove the drain plug (1) and drain the transmission fluid into a suitable container. Dispose of the fluid properly.

Install the drain plug (1).

Remove the strainer cover plate (2) and clean the strainer with diesel fuel. Replace the strainer if it is damaged in any way.

Install the strainer and cover plate (2).

- Transmission Fluid Strainer
Part Number: 300000095

The transmission filter is located on the right side of the transmission, next to the park brake canister.

Turn the filter counterclockwise to remove. Dispose of the filter properly.

NOTICE: DO NOT over-tighten the filter. Damage to the seal can result.

Lubricate the seal on the transmission fluid filter.

Transmission Fluid Filter Part Number: 300000101

Install and tighten the filter, by hand, 3/4 to 1-1/4 turns after the seal contacts the filter housing.

NOTICE: DO NOT overfill the transmission fluid. Overfilling can damage the transmission or cause the transmission to malfunction.

NOTICE: Use only Lucas Universal Hydraulic Fluid or equivalent.

Use a funnel to fill the transmission fluid at the transmission dipstick tube on the left side of the engine.

- Transmission Fluid Capacity: Approximately 16 quarts [15 liters].

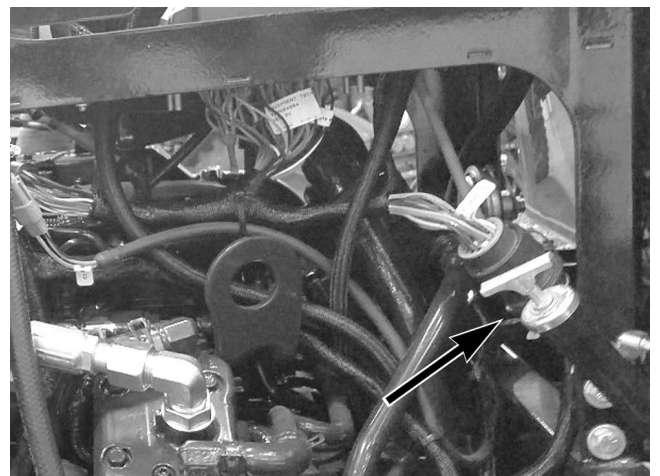
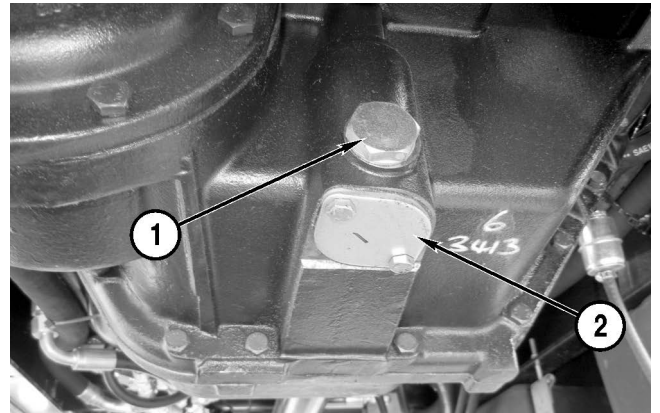

Check the transmission fluid level with the transmission fluid at normal operating temperature, transmission in NEUTRAL position, and the engine off.

The fluid level should be between the two dots on the dipstick.

Install the dipstick and turn the handle clockwise to tighten.

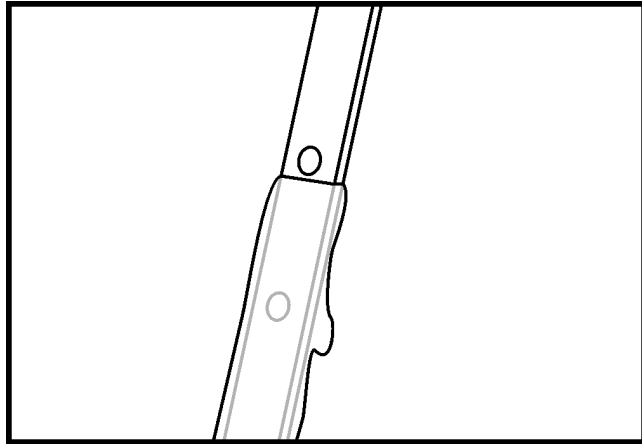

Inspect and Repack Wheel

Contact your dealer to inspect and repack the wheel (1).

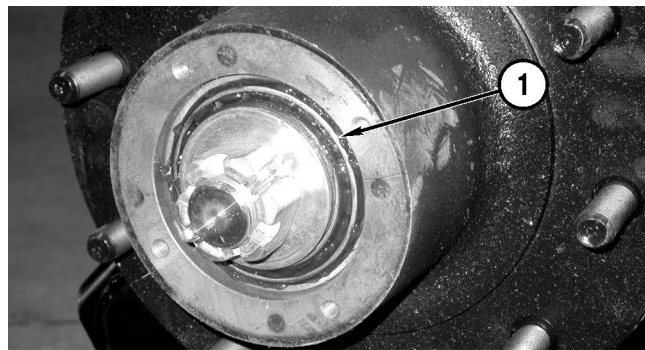

Change Final Drive Fluid

The Apache Sprayer is equipped with a drop box.

Drop Box

The drop box drain, level and fill plugs are located on the drop box at each rear wheel. The left drop box is shown.

Remove the drain plug (1) and the fill/level plug (2). Drain the fluid into a suitable container. Dispose of the fluid properly.

Install the drain plug (1).

NOTICE: Use only Lucas 80/90 Gear Oil or equivalent for the drop box fluid.

Add fluid until it is level with the bottom of the level hole (2).

- Drop Box Fluid Capacity:
Approximately 21 quarts [20 liters]

Install and tighten the fill/level plug (2).

Repeat the steps for the other drop box.

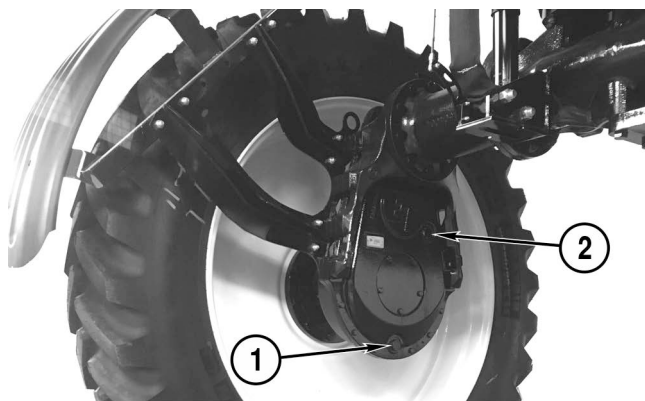

Change Cab Charcoal Filter

NOTICE: DO NOT attempt to clean the old cab air filter. ALWAYS replace with a new filter.

The charcoal air filter is located under the cab, connected to the A/C box.

Remove the knob screw (1) by turning to the left to loosen.

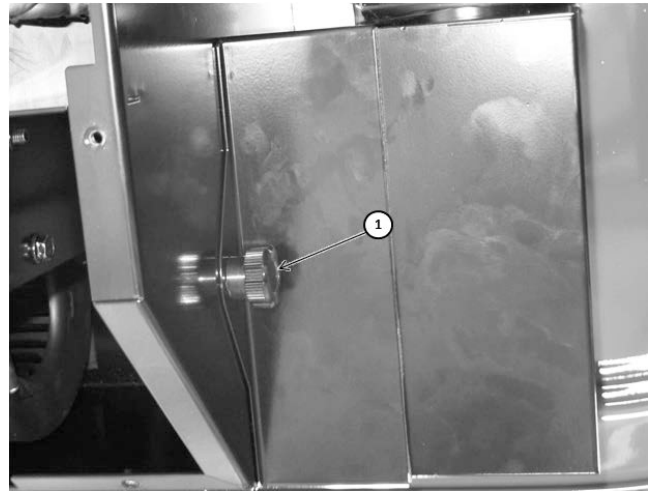

Remove and discard the filter (1) by sliding it out.

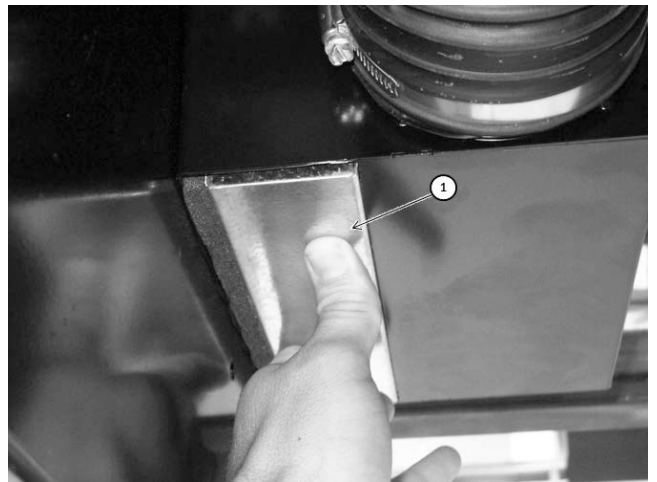

Insert the new filter into the frame with the air-flow arrow pointing toward the A/C box.

- Charcoal Air Filter
Part Number: 490003651

Close the cover and install the knob screw by turning to the right to tighten.



Every Year

The following services must be performed every year.

Adjust Toe-In

Measure Toe-In

Safely lift the front of the Apache Sprayer so the front tires are slightly off of the ground.

Turn the steering wheel so the front wheels are pointing straight.

Measure and note the distance between the left and right tires at the front (1) of the tires and at the rear (2) of the tires.

The distance at the front (1) of the tires should be 0.25 in. [6.35 mm] less than at the rear (2) of the tires for 90-inch axles and 0.375 [9.63 mm] in less than the rear for 120-inch axles. Adjust accordingly.

If the toe-in is not approximately 0.25 in. [6.35 mm], the toe-in must be adjusted.

Adjust Toe-in

Loosen the jam nut (1) at each end of the tie rods.

Turn the tie rod clockwise (as viewed from the left side) to increase toe-in.

Turn the tie rod counterclockwise (as viewed from the left side) to decrease toe-in.

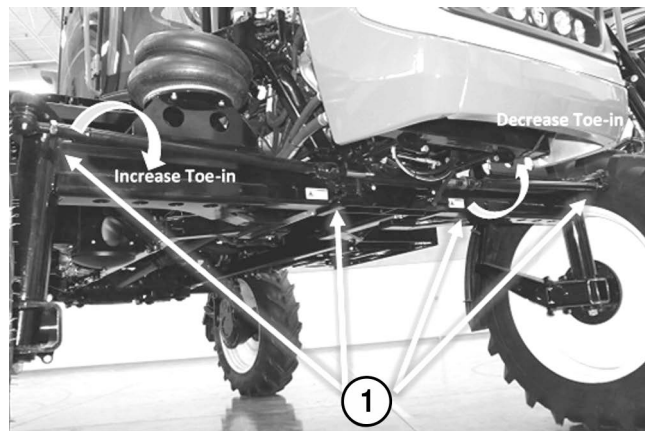
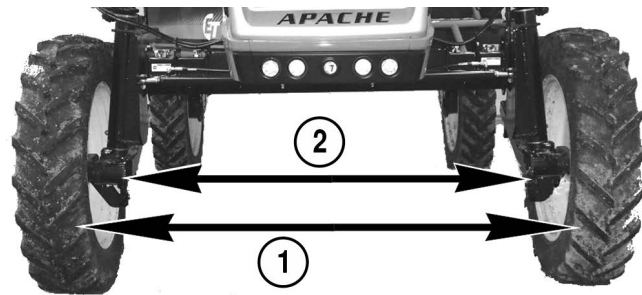

Change Engine Safety Air Filter

NOTICE: DO NOT attempt to clean the engine safety air filter. ALWAYS replace with a new filter.

The engine safety air filter (1) is mounted in the engine compartment, above the engine and toward the cab. It is in the same housing as the primary engine air filter.

Release the four latches (2) remove the cover from the air cleaner assembly and remove the primary air filter and set it aside.

NOTICE: DO NOT leave the intake opening uncovered. If not replacing the filter immediately, cover the opening to prevent dirt and debris entering the intake system.

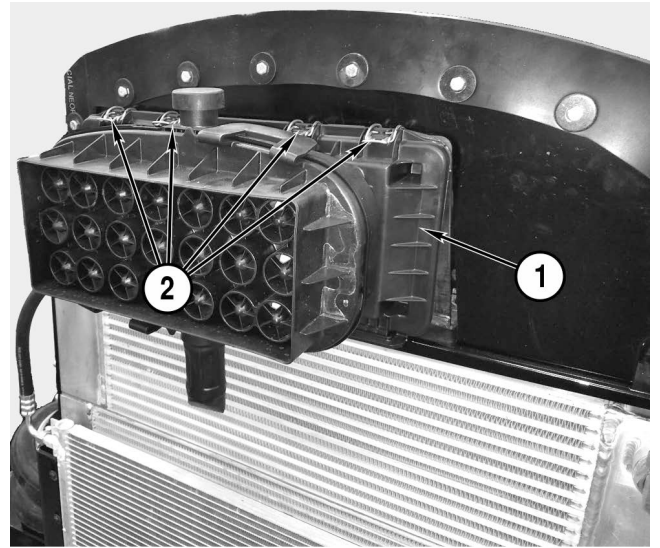

Use the pull tabs (2) to remove the engine safety air filter (1) and discard the old filter.

Install the new engine safety air filter.

- Engine Safety Air Filter
Part Number: 201300141

Install the primary filter, air cleaner cover, and engage the four latches.

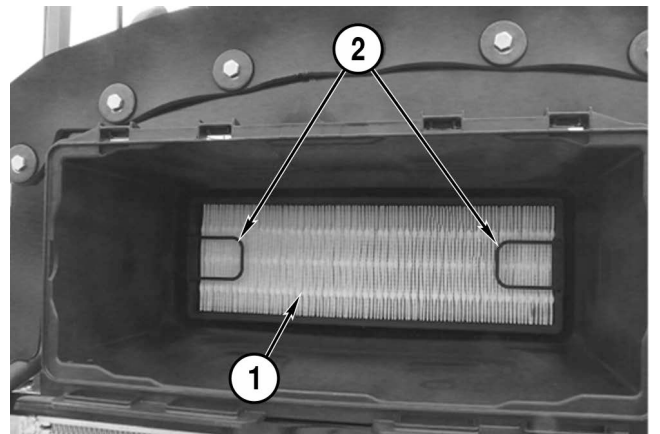

Winterize Wet System

The product tank and wet system must be flushed before winterizing. See “Flushing Product Tank” on page 4-17.

Open the product tank fill valve, rinse tank valve, and roto-flush valve to drain any remaining water in the tanks and roto-flush line.

Remove the end caps and set all boom sections to the ON position.

Turn agitation off by pushing the agitation/roto-flush button (1) to OFF, LED is RED.

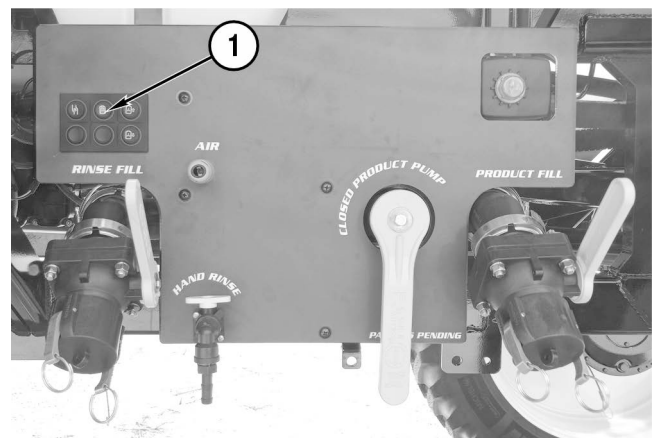

Connect a compressed air line to the main fill valve (1). Apply compressed air at 40 psi [2.7 bar] to blow out the wet system and booms.

Cycle the boom sections (2) off and on several times to purge water from around the valves.

Disconnect the air line and close the product fill valve.

NOTICE: Drain the rinse tank, hand rinse tank, and any other tanks equipped to prevent damage during storage.

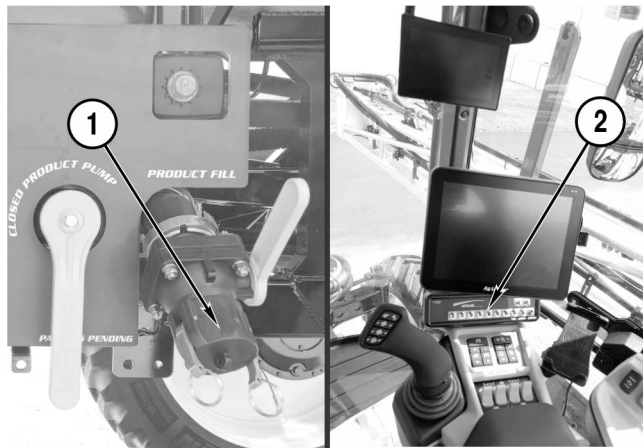

Remove all boom section strainers (1) and the product strainer.

Reinstall the strainer bowls.

Store the strainers in a warm, dry location.

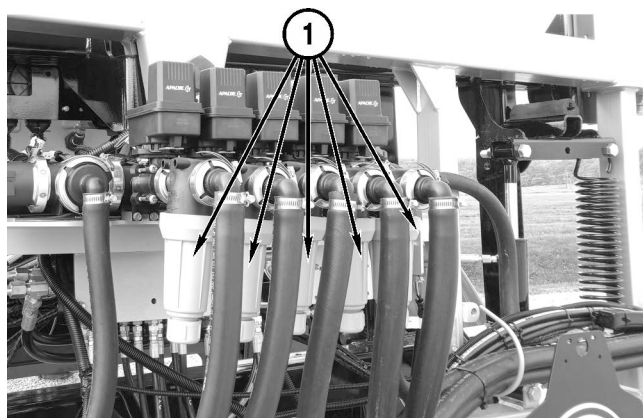

Pour approximately 20 gallons [76 liters] of RV anti-freeze into the product tank.

NOTICE: Boom lengths over 60 ft will require more than 20 gallons [76 liters] of antifreeze.

Pour 1 gallon [4 liters] of RV antifreeze into the rinse tank.

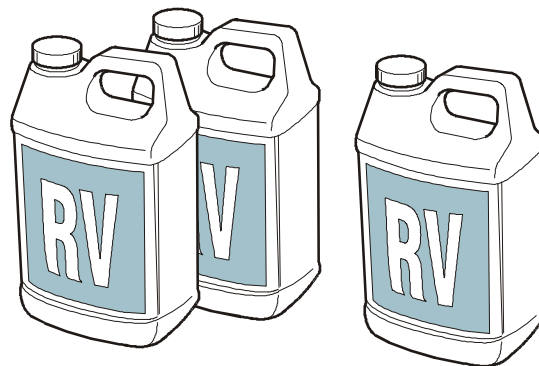

Repeatedly open and close the sump valve (1) and rinse tank/product valve (2), to allow the antifreeze to surround the ball valves.

Close the rinse tank valve (2) and open the sump valve (1).

Except for one nozzle at the end of each boom section, turn off all the nozzle bodies.

Open all manual valves halfway and then close to allow any trapped water to escape.

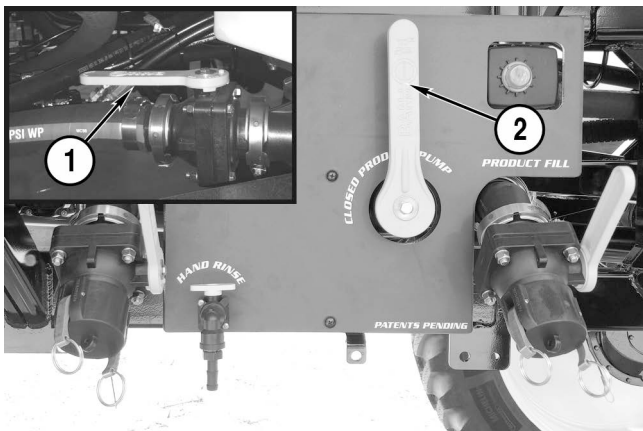

NOTICE: DO NOT run the product pump dry. Damage to the pump seals will result. DO NOT intentionally dead-head the pump with high pressures. Damage to the pump seals will result.

Start the engine.

Unfold and lower the booms as far as possible.

Set all boom sections to the OFF position and press the agitation increase button (1).

Set the product pump button (2) to the ON position.

Press the agitation decrease button (2) to turn agitation off.

One at a time, set the boom sections to the ON position until antifreeze flows from the open nozzle in each boom section.

Turn the boom sections to OFF.

Set the product pump switch (3) to the OFF position.

NOTE: Excess antifreeze may be left in the sprayer.



Every 1000 Hours or Yearly

The following services must be performed after every 1000 hours of operation or yearly.

Change Hydraulic Fluid

The hydraulic fluid drain plug (1) is located on the hydraulic fluid reservoir, between the cab and the product tank.

Remove the hydraulic fluid drain plug (1) from the bottom of the reservoir and drain the fluid into a suitable container with a capacity of approximately 23 gallons [87 liters]. Dispose of the fluid properly.

Install the drain plug (1).



NOTICE: Use only Lucas Universal Hydraulic Fluid or equivalent for the Apache Sprayer hydraulic system.

Remove the hydraulic fluid reservoir cap and fill with Lucas Universal Hydraulic Fluid or equivalent.

- Hydraulic Fluid Reservoir Capacity:
Approximately 23 gallons [87 liters].

Use the sight glass (1) to check the fluid level. See “Check Hydraulic Fluid Level” on page 5-15.

NOTE: The sight glass also shows hydraulic fluid temperature.

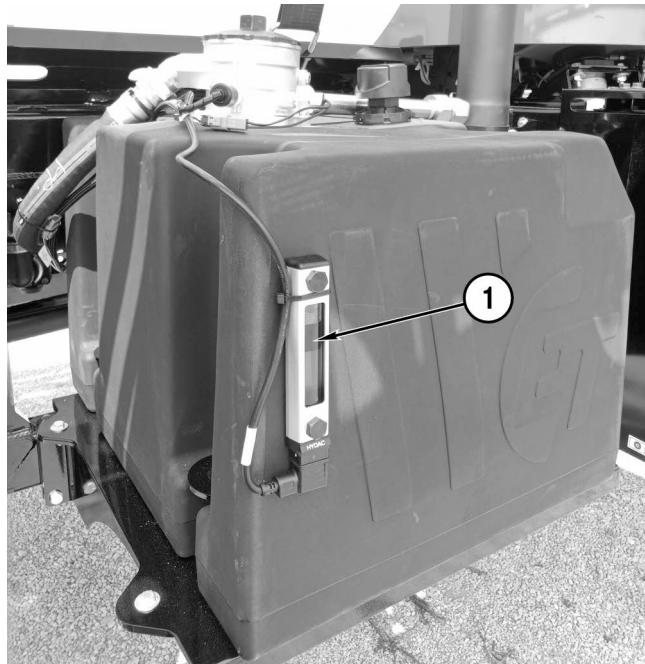

Change DEF Suction Strainer

The DEF suction strainer is located in the DEF tank on the left side of the machine.

To reduce the possibility of injury from hot coolant spray, turn the engine off and, with locking pliers, pinch the DEF heater hoses closed. The heater hoses are a larger diameter hose and connect to the larger fittings on the unit.

Note hose location for assembly.

Disconnect all the hoses and drain the fluids into a suitable container. Dispose the fluids properly.

Remove the two screws (1) and retaining ring (2) that hold the DEF level/temperature unit (3) in place.

Lift the unit out of the tank and remove the suction screen retaining screw (1) from the foot of the suction tube. Remove the screen and replace it with a new one.

- DEF Suction Strainer
Part Number: 241000008

Place the DEF level/temperature unit back into the tank and orient the hose barb as they were originally.

Install the retaining ring and mounting screws. Tighten the screws to 20 to 30 in. lb. [2.26 to 3.38 N•m]

Connect the hoses and release to clamps on the heater hoses.

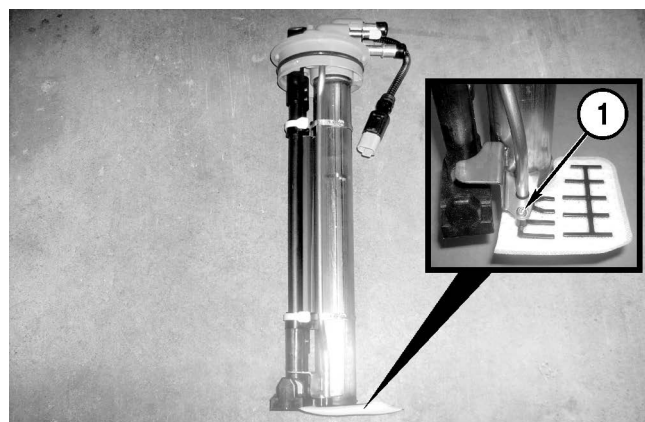
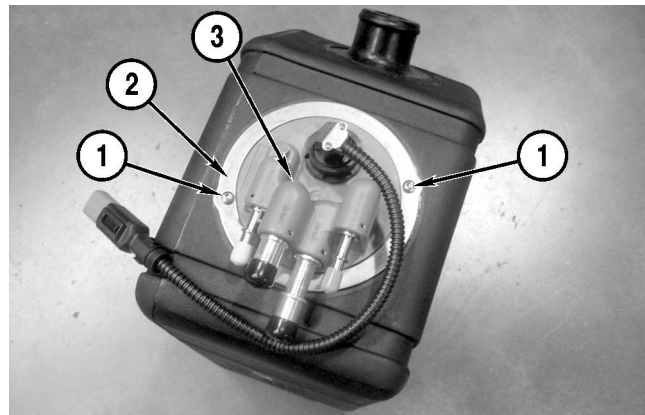

Every 2000 Hours

The following services must be performed after every 2000 hours of operation of the Apache Sprayer.

Change Crankcase Ventilation Filter

Disconnect the crankcase ventilation hose.

Grasp either the top inlet cover (1) or the bottom drain cover (2) and turn counterclockwise to remove the filter element from the crankcase ventilation breather housing.

The new filter can be installed with either end up.

Install the breather housing cover by rotating clockwise.

Tighten hand-tight.

- Crankcase Ventilation Filter
Part Number: 210504007

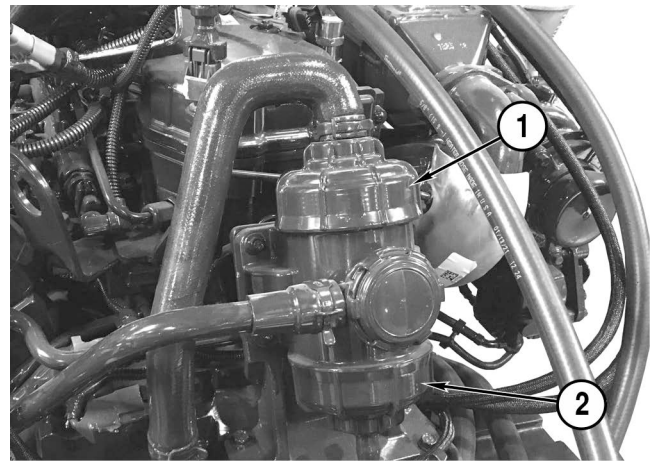

Every 4500 Hours or 3 Years

The following services must be performed after every 4500 hours or 3 years of operation.

Change DEF Supply Module Filter

Remove the DEF filter cap (1) and filter from the supply module.

Install the new filter and replace the cap.

- DEF Supply Module Filter
Part Number: 241000009

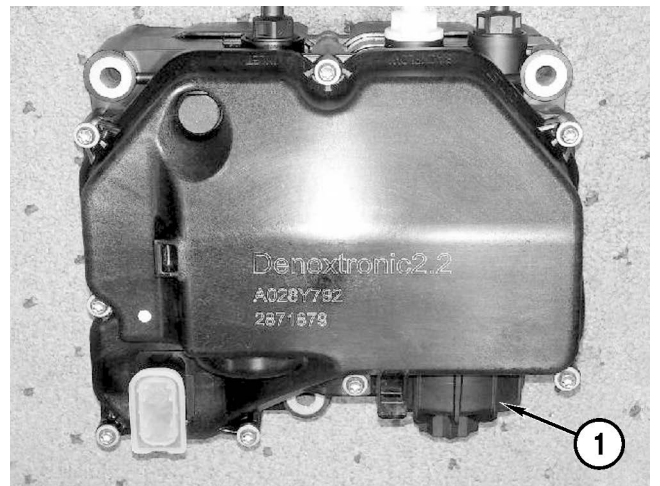

APACHE™

CHAPTER 6

TORQUE VALUE CHARTS

Fittings

ALWAYS tighten fittings to the values below unless a different torque value is specified.

Make sure fitting threads are clean and threads are engaged properly.

All torque values are adopted from SAE J514 and SAE J1453.

Size Chart

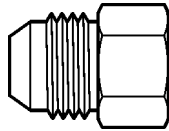
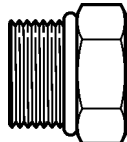
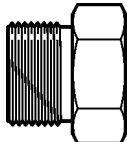
SAE Dash Size			
	SAE (JIC) 37° Flare Thread	O-ring Style Straight Thread	Face Seal
	Size	Size	Size
2	5/16-24	5/16-24	----
3	3/8-24	3/8-24	----
4	7/16-20	7/16-20	9/16-18
5	1/2-20	1/2-20	----
6	9/16-18	9/16-18	11/16-16
8	3/4-16	3/4-16	13/16-16
10	7/8-14	7/8-14	1-14
12	1 1/16-12	1 1/16-12	1 3/16-12
14	1 3/16-12	1 3/16-12	----
16	1 5/16-12	1 5/16-12	1 7/16-12
20	1 5/8-12	1 5/8-12	1 11/16-12
24	1 7/8-12	1 7/8-12	2-12
32	2 1/2-12	2 1/2-12	----



Torque Value Chart

SAE Dash Size	TORQUE					
	SAE 37° Flare		O-ring Straight Thread		Face Seal	
	lb-ft	N•m	lb-ft	N•m	lb-ft	N•m
2	4	5	4	5	----	----
3	8	11	9	12	----	----
4	12	16	16	22	18	25
5	15	20	22	30	---	---
6	18	25	35	48	27	37
8	37	50	60	82	40	54
10	48	65	105	143	63	86
12	74	100	140	190	92	125
14	88	120	184	250	----	----
16	100	135	221	300	122	165
20	133	180	258	350	147	200
24	166	225	317	430	166	225
32	236	320	----	----	----	----





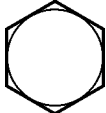

Bolts

ALWAYS tighten bolts to the values below unless a different torque value is specified. Fasteners must ALWAYS be replaced with the same grade. Make sure bolt threads are clean and threads are engaged properly. All torque values are derived from Machinery’s Handbook, Mechanical Engineering Design, SAE J1701 and SAE J1701M.

SAE Series Torque Value Chart

										
A = Bolt Diameter		SAE Grade 2 (No Markings)			SAE Grade 5 (3 Radial Dashes)			SAE Grade 8 (6 Radial Dashes)		
A Diam. (In) and thread pitch	Wrench Size	FASTENER COATING								
		SAE Grade 2 Torque lb-ft [N•m]			SAE Grade 5 Torque lb-ft [N•m]			SAE Grade 8 Torque lb-ft [N•m]		
		Dry	Zinc Plated	Lubri- cated	Dry	Zinc Plated	Lubri- cated	Dry	Zinc Plated	Lubricated
1/4-20	7/16"	6 [8]	5 [7]	4 [5]	8 [11]	7 [9]	6 [8]	12 [17]	11 [15]	9 [12]
1/4-28	7/16"	6 [8]	5 [7]	4 [5]	10 [13]	9 [12]	7 [9]	14 [18]	12 [17]	10 [13]
5/16-18	1/2"	11 [15]	10 [13]	8 [11]	17 [23]	15 [20]	13 [18]	25 [34]	22 [30]	18 [24]
5/16-24	1/2"	12 [17]	11 [15]	9 [12]	19 [26]	17 [23]	14 [19]	27 [37]	24 [32]	20 [27]
3/8-16	9/16"	20 [27]	18 [24]	15 [20]	31 [42]	28 [38]	23 [31]	44 [60]	39 [53]	38 [52]
3/8-24	9/16"	23 [31]	20 [27]	17 [23]	35 [47]	31 [42]	26 [35]	49 [67]	44 [60]	37 [50]
7/16-14	5/8"	32 [43]	29 [39]	24 [32]	49 [66]	44 [60]	37 [50]	70 [95]	63 [85]	61 [83]
7/16-20	5/8"	36 [48]	32 [43]	27 [37]	55 [75]	50 [68]	41 [56]	78 [106]	70 [95]	58 [79]
1/2-13	3/4"	49 [66]	44 [60]	37 [50]	75 [102]	68 [92]	57 [77]	106 [144]	96 [130]	93 [126]
1/2-20	3/4"	55 [75]	49 [66]	41 [56]	85 [115]	76 [103]	64 [87]	120 [163]	108 [146]	105 [142]
9/16-12	13/16"	70 [95]	63 [85]	55 [75]	110 [149]	100 [136]	80 [108]	150 [203]	130 [176]	110 [149]
9/16-19	13/16"	78 [106]	70 [95]	60 [81]	121 [164]	110 [149]	90 [122]	171 [232]	157 [213]	130 [176]
5/8-11	15/16"	97 [131]	87 [118]	73 [99]	150 [203]	135 [183]	113 [153]	212 [287]	191 [259]	159 [216]
5/8-18	15/16"	110 [149]	99 [134]	82 [111]	170 [230]	153 [207]	127 [172]	240 [325]	216 [293]	180 [244]
3/4-10	1 1/8"	172 [233]	155 [210]	129 [175]	267 [362]	240 [325]	200 [271]	376 [510]	339 [460]	282 [382]
3/4-16	1 1/8"	192 [261]	173 [235]	144 [195]	297 [403]	267 [362]	223 [302]	420 [570]	378 [513]	315 [427]
7/8-9	1 5/16"	167 [226]	150 [203]	125 [169]	429 [582]	386 [523]	322 [437]	606 [822]	545 [739]	455 [627]
7/8-14	1 5/16"	184 [250]	165 [224]	138 [187]	474 [642]	426 [578]	355 [481]	669 [907]	602 [816]	677 [918]
1/8	1 1/2"	250 [339]	225 [305]	187 [254]	644 [873]	579 [785]	483 [665]	909 [1232]	818 [1109]	681 [923]
1-12	1 1/2"	274 [371]	246 [334]	205 [278]	722 [979]	634 [860]	528 [716]	1020 [1383]	895 [1213]	746 [1011]

Metric Series Torque Value Chart

 Diameter and Thread Pitch (Millimeters)	Wrench Size	 Metric Grade 8.8		 Metric Grade 10.9		 Metric Grade 8.8		 Metric Grade 10.9		 Diameter and Thread Pitch (Millimeters)
		Course Thread				Fine Thread				
		Metric 8.8		Metric 10.9		Metric 8.8		Metric 10.9		
		N•m	lb-ft	N•m	lb-ft	N•m	lb-ft	N•m	lb-ft	
6 x 1.0	10	8	6	11	8	8	6	11	8	6 x 1.0
8 x 1.25	13	20	15	27	20	21	16	29	22	8 x 1.0
10 x 1.5	16	39	29	54	40	41	30	57	42	10 x 1.25
12 x 1.75	18	68	50	94	70	75	55	103	76	12 x 1.25
14 x 2.0	21	109	80	151	111	118	87	163	120	14 x 1.5
16 x 2.0	24	169	125	234	173	181	133	250	184	16 x 1.5
18 x 2.5	27	234	172	323	239	263	194	363	268	18 x 1.5
20 x 2.5	30	330	244	457	337	367	270	507	374	20 x 1.5
22 x 2.5	34	451	332	623	460	495	365	684	505	22 x 1.5
24 x 3.0	36	571	421	790	583	623	459	861	635	24 x 2.0
30 x 3.0	46	1175	867	1626	1199	1258	928	1740	1283	30 x 2.0

APACHE™

CHAPTER 7

TROUBLESHOOTING

Apache Sprayer Troubleshooting Symptoms and Solutions

If your issue was not resolved by using the troubleshooting guide, contact your dealer for more help.

SYMPTOM	SOLUTION
Parking brake will not engage.	Check electrical coil on hydraulic junction block, under cab, for power. Check hose connections to brake canister on transmission.
Apache Sprayer will not move forward or backward.	Parking brake is engaged. Check electrical connections on parking brake and transmission.
Constant alarm sounds when Apache Sprayer moves forward or backward.	Check transmission fluid level. Check wire connection at sending unit. Check transmission temperature sensor.
Apache Sprayer will not move forward.	Check driveshaft. Check transmission fluid level. Check electrical connections on transmission.
Apache Sprayer will not move backward.	Check driveshaft. Check transmission fluid level. Check electrical connections on transmission.
Engine will not start.	Confirm battery disconnect button is "ON". Check diesel fuel level. Check neutral safety relay.
Apache Sprayer steering does not work.	Check hydraulic fluid level. Check for hydraulic fluid leaks. Check steering column coupling on steering motor.
Transmission will not shift gears.	Check transmission fluid level.
Apache Sprayer brakes do not work.	Check brake hoses for leaks. Check push rods on master cylinder.

SYMPTOM	SOLUTION
No power to console in cab.	Check electrical connections in right rear corner of cab, near fuse box.
Road and service lights do not work.	<p>Confirm light buttons are “ON”.</p> <p>Check electrical connections to the light pad, cabin power distribution module, and the firewall distribution module.</p> <p>Check for power at light bulbs.</p> <p>Check appropriate fuses.</p>
Turn signals and/or flashers do not work.	<p>Confirm lever/switch in “ON” position.</p> <p>Check electrical connections at light housings.</p> <p>Check for power at light housings.</p>
Booms will not fold or unfold.	<p>Confirm engine is running.</p> <p>Check hydraulic fluid level.</p> <p>Confirm booms are greased properly.</p> <p>Check for hydraulic fluid leaks.</p> <p>Check electrical connections in cab and at boom manifold.</p>
Booms will not tilt up or down.	<p>Confirm engine is running.</p> <p>Check hydraulic fluid level.</p> <p>Check for hydraulic fluid leaks.</p> <p>Check electrical connections in cab and at boom manifold.</p>
Apache Sprayer will not spray.	<p>Confirm engine is running.</p> <p>Confirm product in product tank.</p> <p>Confirm ball valves from tank to product pump are open.</p> <p>Confirm product pump is turned on.</p> <p>Check ground speed on console controller display.</p> <p>Confirm boom valves are opening. If they are not, check appropriate fuses and back rack electrical connections.</p>
Product boom valves will not turn on.	<p>Unplug electric connection at valve for 20 seconds.</p> <p>Check electrical connections in cab.</p> <p>Check fuse block in cab.</p>
Product boom valves will not turn off.	<p>Check boom valves for operation.</p> <p>Check electrical connections at boom valves.</p> <p>Check electrical connections in cab.</p> <p>Check power module in cab.</p>

SYMPTOM	SOLUTION
Seat will not raise or lower.	Check power module in cab. Check wire connections at right side of seat. Check for air leaks.
Raven monitor does not turn on.	Check power module in cab. Check electrical connections at the monitor.
Front suspension air bags will not inflate.	Check electric leveling valve wires for frays or disconnected wires. Check air hoses for leaks or damage.
Rear suspension air bags will not inflate.	Check manual leveling valve for damage. Check air hoses for leaks or damage.
Product pump will not turn on.	Confirm product pump button is on and indicator is lit. Check electrical connections at hydraulic valve block. Check electrical connections in cab.
A/C does not cool.	Confirm A/C button is "ON". Confirm fan is "ON". Check belt to compressor.
Rack still moves when rack lock is engaged.	Check voltage to solenoid at rack lock manifold. Perform clean out procedure of rack lock manifold.

APACHE™

CHAPTER 8

ELECTRICAL SYSTEM

Fuse and Relay Diagrams

The fuse diagrams are on the following pages. There are two fuse boxes, with a third one depending on optional precision packages purchased.

The chassis fuse box is located near the battery box.



The cab fuse box is located on the cab floor to the right of the operator seat. (Remove the cover panel.)

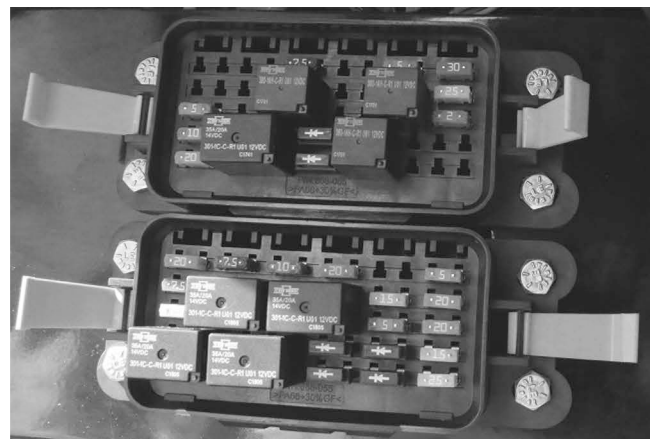

Chassis - Fuse Diagram

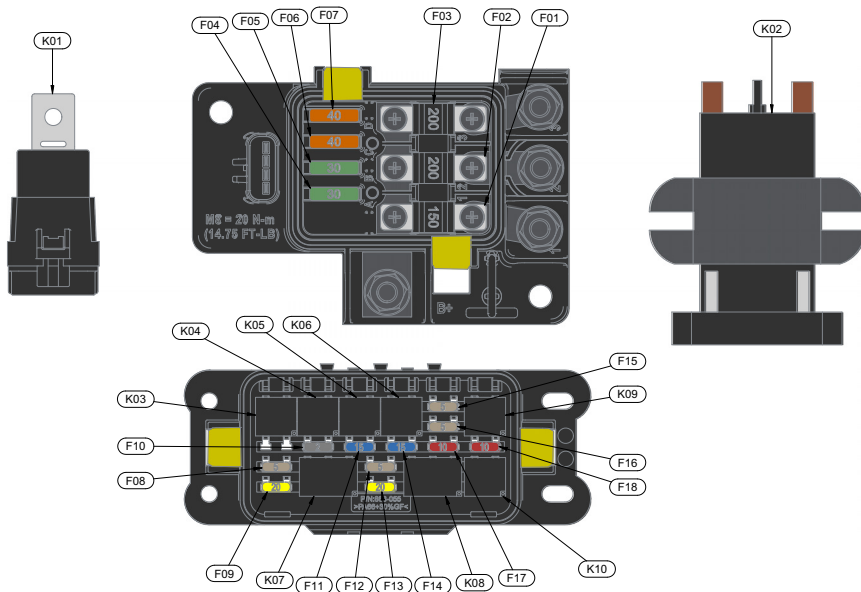

NUMBER	DESCRIPTION	RATING
F01	CAB BATTERY POWER	150A
F02	ALTERNATOR POWER	200A
F03	COLD START POWER	200A
F04	BOOM VALVE POWER	30A
F05	ENGINE ECU POWER	30A
F06	NOT USED	40A
F07	STARTER SOLENOID POWER	40A
F08	MARKER LIGHT POWER	5A
F09	HEADLIGHT POWER	20A
F10	POI POWER	2A
F11	DEF LINE HEATER POWER	15A
F12	REARVIEW LIGHT POWER	5A
F13	BOOM LIGHT POWER	20A
F14	DEF SUPPLY MODULE HEATER POWER	15A
F15	HVAC IGNITION POWER	5A
F16	ENGINE IGNITION POWER	5A
F17	ENGINE A-T SENSOR POWER	10A
F18	CHASSIS IGNITION POWER	10A
K01	STARTER RELAY	SPDT 12V/40A
K02	COLD START SOLENOID	SPST 12V/225A
K03	DEF LINE HEATER 1 RELAY	SPST 12V/20A
K04	DEF LINE HEATER 2 RELAY	SPST 12V/20A
K05	DEF LINE HEATER 3 RELAY	SPST 12V/20A
K06	DEF SUPPLY MODULE HEATER RELAY	SPST 12V/20A
K07	HEADLIGHT RELAY	SPDT 12V/35A
K08	BOOM LIGHT RELAY	SPDT 12V/35A
K09	STARTER LOCKOUT RELAY	SPST 12V/20A
K10	IGNITION RELAY	SPST 12V/20A

Cab - Fuse Diagram

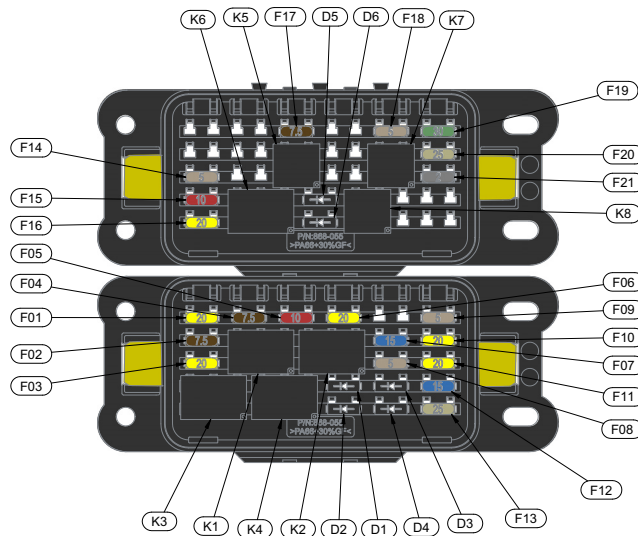

NUMBER	DESCRIPTION	RATING
D1	WIPER LOW SWITCH DIODE	1A
D2	WIPER PULSE DIODE	1A
D3	WIPER HIGH SWITCH DIODE	1A
D4	WIPER PARK DIODE	1A
D5	RAVEN SWITCH SIGNAL DIODE	1A
D6	TRIMBLE SWITCH SIGNAL DIODE	1A
F01	SEAT POWER	20A
F02	CAB HVAC IGNITION POWER	7.5A
F03	HVAC BLOWER POWER	20A
F04	STEERING COLUMN IGNITION POWER	7.5A
F05	ARMREST IGNITION POWER	10A
F06	ACCESSORY POWER	20A
F07	IGNITION SWITCH BATTERY POWER	15A
F08	ARMREST BATTERY POWER	5A
F09	SPU BATTERY POWER	5A
F10	FRONT WORKLIGHT POWER	20A
F11	REAR WORKLIGHT POWER	20A
F12	CAB ROOF POWER	15A
F13	WIPER POWER	25A
F14	ANTENNA POWER	5A
F15	TRIMBLE SWITCHED POWER	10A
F16	NODE LOGIC POWER	20A
F17	MASTER SPRAY POWER	7.5A
F18	CONSOLE IGNITION POWER	5A
F19	NODE HIGH CURRENT POWER	30A
F20	CONSOLE BATTERY POWER	25A
F21	ISOBUS CAN POWER	2A
K1	IGNITION RELAY 1	SPDT 12V/35A
K2	IGNITION RELAY 2	SPDT 12V/35A
K3	WIPER HIGH SPEED RELAY	SPDT 12V/35A
K4	WIPER PARK RELAY	SPDT 12V/35A
K5	MASTER SPRAY RELAY	SPST 12V/20A
K6	CONSOLED SWITCHED RELAY	SPDT 12V/35A
K7	CONSOLE IGNITION RELAY	SPST 12V/20A
K8	TRIMBLE SWITCH SIGNAL RELAY	SPST 12V/20A

APACHE™

CHAPTER 9

WARRANTY

Apache Sprayer Warranty Registration and Policy For all 2025 Model Year

Apache Sprayer Machine Warranty Registration

This is performed by the selling Apache Sprayer dealer and must be completed within fourteen (14) calendar days from delivery to end user.

Apache Sprayer Engine Warranty Registration

This is performed by the selling Apache Sprayer dealer: To register the Cummins engine for warranty first have the engine serial number, then go to www.cummins.com click on “product registration” read the terms and conditions. If you agree with the terms and conditions, then click on “I accept”, and follow the instructions to register. This must be completed within fourteen (14) calendar days from delivery to end user. (When registering the sprayer on www.etdealer.com, a link is provided to the Cummins website and all of the customer information auto-fills from the etdealer.com registration form.)

APACHE SPRAYER LIMITED WARRANTY POLICY

Equipment Technologies (hereinafter called ET) warrants each new Apache Sprayer to be free from defects in materials and workmanship for a period of five (5) years or two thousand (2000) hours, whichever occurs first, from the warranty start date, with the exclusions listed herein. Under no circumstances does this limited warranty cover any merchandise or component parts, which, in the sole opinion of ET, have been subject to negligence, misuse, improper storage, alteration, accident, or if repairs have been made with parts other than those manufactured, supplied, and/or authorized by ET. Under no circumstances are component parts warranted against normal wear and tear.

There is no warranty on glass, parking brake pads or discs, brake linings, filters, oils, product pump seals, product pump bearings, rubber product hoses, pressure gauges or ground engaging accessories such as auto boom wheels and related bearings, shocks, or springs.

Components, systems, or accessories that are installed by the dealer and were not installed by ET when the machine was originally manufactured are not covered by this warranty.

First and Second Year - Limited warranty covers the total machine for the first two years from warranty start date or one thousand (1000) hours whichever occurs first, for parts, labor, and mileage. Under no circumstances does this limited warranty cover any merchandise or component parts, which, in the sole opinion of ET, have been subject to negligence, misuse, improper storage, alteration, accident, or if repairs have been made with parts other than those manufactured, supplied, and/or authorized by ET. For engine, tire, and battery warranty please see below.

Years Three through Five - Limited warranty covers some power train and chassis components for parts only from the warranty start date or two thousand (2000) hours whichever comes first. The following components are covered under years three through five of warranty: Transmission and its internal components (excludes park brake components, harness, electrical components, main drive shafts and u-joints), differential and its internal components, front axle assembly (excludes seals, bearings, wear pads, suspension cylinder (i.e. front strut), outer flex, hubs, accumulator, and steering cylinders), frame rails, engine bolster, rear axle assembly (excludes wear pads, output drive shafts, and rear suspension components), planetary and its internal components (excludes bearings, seals, and o-rings), drop boxes and their internal components (excludes bearings and seals), frame cross members and any bracket that bolts directly to the frame rails. This portion of coverage is subject to all listed conditions but further excludes oil, seals, gaskets and leakage, and all park brake components.

Engine Warranty - The limited engine warranty is covered by Cummins Inc. for two (2) years or two thousand (2000) hours from the warranty start date, whichever comes first. ET does warrant the a/c compressor and alternator for first and second year. Cummins Inc. warrants all other bolt on and engine components. See engine warranty for complete details.

Tires - Warranty for Michelin tires will be handled through your local authorized Michelin dealer. Please contact ET if you have any questions.

Batteries - Batteries are warranted for thirty (30) months through NAPA auto part stores.

ET's obligation under this limited warranty is limited to repairing or replacing free of charge to the original purchaser, at a location designated by ET, any part that in ET's sole judgment, shows evidence of defect or improper workmanship, provided that the part is returned to ET within thirty (30) calendar days of the issue of an automatically or manually generated RMA. Parts must be returned through the authorized selling dealer, transportation charges prepaid. All returned parts must be clean from all chemicals and/or oils.

ET's obligation under this limited warranty is in lieu of all other warranties or representations, expressed or implied, and specifically excludes any obligations or liability for loss of crops, losses caused by harvest delays or any expense or loss of labor, supplies, rental equipment, and all incidental or consequential damages. The replacement of parts and/or repair is the exclusive remedy under this limited warranty. ET reserves the right to repair or replace any defective part or parts. No person is authorized to give any other warranties or to assume any other liability on ET's behalf. This limited warranty is void if ET's limited warranty policy maintenance standards are violated.

ET makes NO warranty of merchantability or fitness for a particular purpose.

All inquires about this warranty policy should be addressed to:

Warranty Department • 455 Merriman Road • Mooresville, IN • 46158

Telephone: 317-834-4500

APACHE™

CHAPTER 10

MAINTENANCE LOG

_____ Season

Check and inspect each of the following items on your Apache Sprayer. Put the date on the line next to each item as it is completed.

	Grease the front axle king-pins. Check all front axle bolts for proper torque.
	Clean radiator and cooling package of all debris, check all radiator and cooling package hoses to make sure they are tight and not leaking.
	Change engine oil and replace filters.
	Service fuel system and replace filters.
	Service transmission; change oil and replace filter, remove suction screen, clean and inspect for damage.
	Replace cab filters.
	Remove and replace engine air filters, check intake clamps to make sure they are tight.
	Grease the U-joints on all driveshafts and inspect each U-joint for wear and missing caps.
	Inspect carrier bearing on the front driveshaft for wear and damaged rubber.
	Service rear differential.
	Check all rear axle bolts for proper torque.
	Service the hydraulic system oil, replace return filters, remove suction screens, clean and inspect for damage.
	Remove all product screens from strainers, clean and inspect for damage. Replace as needed.
	Flush the wet system with clean water, remove inspection plug from product pump and inspect impeller for damage. Turn on pump and dead-head the pressure and check at gauge outside of cab, increase and decrease agitation and check gauge for operation. Fold booms out and adjust and grease.

_____ **Season**

Check and inspect each of the following items on your Apache Sprayer. Put the date on the line next to each item as it is completed.

	Grease the front axle king-pins. Check all front axle bolts for proper torque.
	Clean radiator and cooling package of all debris, check all radiator and cooling package hoses to make sure they are tight and not leaking.
	Change engine oil and replace filters.
	Service fuel system and replace filters.
	Service transmission; change oil and replace filter, remove suction screen, clean and inspect for damage.
	Replace cab filters.
	Remove and replace engine air filters, check intake clamps to make sure they are tight.
	Grease the U-joints on all driveshafts and inspect each U-joint for wear and missing caps.
	Inspect carrier bearing on the front driveshaft for wear and damaged rubber.
	Service rear differential.
	Check all rear axle bolts for proper torque.
	Service the hydraulic system oil, replace return filters, remove suction screens, clean and inspect for damage.
	Remove all product screens from strainers, clean and inspect for damage. Replace as needed.
	Flush the wet system with clean water, remove inspection plug from product pump and inspect impeller for damage. Turn on pump and dead-head the pressure and check at gauge outside of cab, increase and decrease agitation and check gauge for operation. Fold booms out and adjust and grease.
	Inspect booms for cracks, breaks, and worn hinge points.
	Inspect boom plumbing for worn hoses and bad nozzles.
	Inspect all hydraulic hoses for rubs, worn spots and leaks.
	Inspect all hydraulic cylinders for leaks and proper operation.
	Inspect wiring harnesses for rub points.
	Verify calibrations:
	Flow Meter

_____ **Season**

Check and inspect each of the following items on your Apache Sprayer. Put the date on the line next to each item as it is completed.

	Grease the front axle king-pins. Check all front axle bolts for proper torque.
	Clean radiator and cooling package of all debris, check all radiator and cooling package hoses to make sure they are tight and not leaking.
	Change engine oil and replace filters.
	Service fuel system and replace filters.
	Service transmission; change oil and replace filter, remove suction screen, clean and inspect for damage.
	Replace cab filters.
	Remove and replace engine air filters, check intake clamps to make sure they are tight.
	Grease the U-joints on all driveshafts and inspect each U-joint for wear and missing caps.
	Inspect carrier bearing on the front driveshaft for wear and damaged rubber.
	Service rear differential.
	Check all rear axle bolts for proper torque.
	Service the hydraulic system oil, replace return filters, remove suction screens, clean and inspect for damage.
	Remove all product screens from strainers, clean and inspect for damage. Replace as needed.
	Flush the wet system with clean water, remove inspection plug from product pump and inspect impeller for damage. Turn on pump and dead-head the pressure and check at gauge outside of cab, increase and decrease agitation and check gauge for operation. Fold booms out and adjust and grease.
	Inspect booms for cracks, breaks, and worn hinge points.
	Inspect boom plumbing for worn hoses and bad nozzles.
	Inspect all hydraulic hoses for rubs, worn spots and leaks.
	Inspect all hydraulic cylinders for leaks and proper operation.
	Inspect wiring harnesses for rub points.
	Verify calibrations:
	Flow Meter

_____ **Season**

Check and inspect each of the following items on your Apache Sprayer. Put the date on the line next to each item as it is completed.

	Grease the front axle king-pins. Check all front axle bolts for proper torque.
	Clean radiator and cooling package of all debris, check all radiator and cooling package hoses to make sure they are tight and not leaking.
	Change engine oil and replace filters.
	Service fuel system and replace filters.
	Service transmission; change oil and replace filter, remove suction screen, clean and inspect for damage.
	Replace cab filters.
	Remove and replace engine air filters, check intake clamps to make sure they are tight.
	Grease the U-joints on all driveshafts and inspect each U-joint for wear and missing caps.
	Inspect carrier bearing on the front driveshaft for wear and damaged rubber.
	Service rear differential.
	Check all rear axle bolts for proper torque.
	Service the hydraulic system oil, replace return filters, remove suction screens, clean and inspect for damage.
	Remove all product screens from strainers, clean and inspect for damage. Replace as needed.
	Flush the wet system with clean water, remove inspection plug from product pump and inspect impeller for damage. Turn on pump and dead-head the pressure and check at gauge outside of cab, increase and decrease agitation and check gauge for operation. Fold booms out and adjust and grease.
	Inspect booms for cracks, breaks, and worn hinge points.
	Inspect boom plumbing for worn hoses and bad nozzles.
	Inspect all hydraulic hoses for rubs, worn spots and leaks.
	Inspect all hydraulic cylinders for leaks and proper operation.
	Inspect wiring harnesses for rub points.
	Verify calibrations:
	Flow Meter

_____ **Season**

Check and inspect each of the following items on your Apache Sprayer. Put the date on the line next to each item as it is completed.

	Grease the front axle king-pins. Check all front axle bolts for proper torque.
	Clean radiator and cooling package of all debris, check all radiator and cooling package hoses to make sure they are tight and not leaking.
	Change engine oil and replace filters.
	Service fuel system and replace filters.
	Service transmission; change oil and replace filter, remove suction screen, clean and inspect for damage.
	Replace cab filters.
	Remove and replace engine air filters, check intake clamps to make sure they are tight.
	Grease the U-joints on all driveshafts and inspect each U-joint for wear and missing caps.
	Inspect carrier bearing on the front driveshaft for wear and damaged rubber.
	Service rear differential.
	Check all rear axle bolts for proper torque.
	Service the hydraulic system oil, replace return filters, remove suction screens, clean and inspect for damage.
	Remove all product screens from strainers, clean and inspect for damage. Replace as needed.
	Flush the wet system with clean water, remove inspection plug from product pump and inspect impeller for damage. Turn on pump and dead-head the pressure and check at gauge outside of cab, increase and decrease agitation and check gauge for operation. Fold booms out and adjust and grease.
	Inspect booms for cracks, breaks, and worn hinge points.
	Inspect boom plumbing for worn hoses and bad nozzles.
	Inspect all hydraulic hoses for rubs, worn spots and leaks.
	Inspect all hydraulic cylinders for leaks and proper operation.
	Inspect wiring harnesses for rub points.
	Verify calibrations:
	Flow Meter
	Boom Sections



WWW.ETSPRAYERS.COM