

APACHETM

A5850

2025 Operator's Manual



**DO NOT OPERATE THIS EQUIPMENT UNTIL THIS MANUAL HAS BEEN READ AND UNDERSTOOD.
ONLY PROPERLY TRAINED PERSONS SHOULD OPERATE THIS MACHINE.**

**EQUIPMENT
TECHNOLOGIES** 

FORM # 580525001
COPYRIGHT 2024
EQUIPMENT TECHNOLOGIES

Apache Sprayer Information

The password for the locked screens on the ET Pilot Touchscreen is "2201".

Dealer: _____

Main Phone# _____

Service Contact: _____

Phone # _____

Parts Contact: _____

Phone # _____

Shop Contact: _____

Phone # _____

Sales Rep: _____

Phone # _____

Precision Rep: _____

Phone # _____

ET / Apache Phone #: _____

Guidance Width/Inches:

of Sections: _____

Boom 1 Cal: _____

Boom 2 Cal: _____

Boom 3 Cal: _____

Boom 4 Cal: _____

Boom 5 Cal: _____

Boom 6 Cal: _____

Boom 7 Cal: _____

Boom 8 Cal: _____

Boom 9 Cal: _____

Product Control:

Speed Cal#: _____

Valve Cal#: _____

Meter Cal#: _____

Valve Advance: _____

Valve Delay: _____

Section Control:

On Look Ahead: _____

Off Look Ahead: _____

Machine Model: _____

Machine Serial #: _____

Engine Serial #: _____

Rate Controller Model: _____

Aux Controller/Display: _____

GPS Antenna Model: _____

GPS Source: _____ GPS Satellite: _____

Height Control: _____

Software Version: _____

Offset: LH Outer: _____ LH Inner: _____

Center: _____ RH Inner: _____

RH Outer: _____

Sensitivity: _____ Speed: _____ Stability: _____

Autosteer: _____ Module Orientation: _____

Software Version: _____

Implement Offsets:

Fore/Aft: _____ Height: _____

Wheelbase: _____

Low Limit/Minimum Flow:

Nozzle Size/Color/Rate _____ = _____

Nozzle Size/Color/Rate _____ = _____

Nozzle Size/Color/Rate _____ = _____

Nozzle Size/Color/Rate _____ = _____

** To maintain minimum spray pattern adjust when changing nozzle size.*

Dear Valued Customer,

Congratulations on the purchase of your new Apache Sprayer, and welcome to the Apache family of owners! We hope that your new Apache Sprayer exceeds your expectations, and gives you years of satisfaction. We invite you to visit us at www.etsprayers.com or in person at our plant in Mooresville, Indiana.

On behalf of all of our employees, we thank you for your business!

Yours Faithfully,

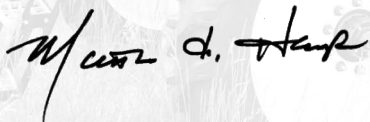

Matthew F. Hays
Chief Executive Officer

NOTICE

Before operating your Apache Sprayer, please check and calibrate the following precision agricultural equipment depending on the machine configuration. Always operate the Apache within the state and local guidelines and regulations.

1. Check all settings and calibrations in your field computers:
 - Swath Width
 - Boom Section Calibration
 - Receiver Fore/Aft Settings
 - Valve Calibration
 - Rate Calibration
 - Low Limit Setting
2. Please review your boom height control and boom spray control settings, if equipped.
3. Please review your plumbing recirculation settings, if equipped.
4. Calibrate the autosteer if equipped. Autosteer calibration must be performed on a large, flat, and open area. Make sure all settings are entered properly, and that calibration is performed in its entirety. This includes driving on an A-B line for roughly 20 minutes after automatic calibration is completed to allow the yaw sensor to learn how to acquire the line properly.

Trademark Information

Ag Leader®

- InCommand™
- SteerCommand Z2™
- DirectCommand® L2
- RightSpot™

CapstanAg®

- PinPoint® III

Caterpillar®

- Cat® TDTO 30

Cummins®**Equipment Technologies (ET)**

- Apache™

Goodyear®**John Deere®**

- Autotrac™

Lucas® Oil Products**Michelin®****NORAC**

- UC7™

Raven Industries

- AccuBoom™
- AutoBoom®
- Raven Boom Recirculation™
- RS1® AutoSteer
- Viper® 4+

Chapter 1: General Information

2025 AS850 Specifications	1-1
Apache AS850 Fluids, Filters and Capacities	1-2
Safety Symbols, Signal Words and Statements	2-1

Chapter 2: Safety

Safety Precautions	2-2
Pre-Operation Hazards	2-2
Fire and Explosion Hazards	2-2
Burn Hazards	2-3
Lifting Hazards	2-3
Exposure Hazard	2-3
Entanglement / Sever Hazard	2-3
Alcohol and Drug Hazard	2-3
Exhaust Emissions Safety	2-4
Environmental Precautions	2-4
Safety Belt	2-4
Safety Decals	2-5
Decal Locations	2-6
Pre-Operation Checks	3-1

Chapter 3: Operation

Cab Overview	3-2
Cab Access Ladder	3-3
Steering Column	3-3
ET Pilot System	3-5
ET Pilot System Touch Screen	3-6
Diagnostics Page 1: Vehicle Warnings	3-8
Active Faults	3-8
Fault History	3-9
Diagnostics Page 2: Parameters	3-10
Diagnostics Page 3: Fan Control	3-10
Diagnostics Page 4	3-11
Engine Control Module Detail View	3-11
Chassis Control Detail View	3-12
Cab Board Controller Detail View	3-13
Armrest Keypad Detail View	3-14
Joystick Detail View	3-14
Display Detail View	3-14
Scheduled Maintenance App	3-15
General Maintenance App Page	3-15
Interval Maintenance App Page	3-15
Maintenance Entry	3-16
Maintenance Reminders	3-16
Vehicle Settings Page 1:	3-17
Vehicle Settings Page 2: Version Information	3-17
Vehicle Settings Page 3:	
Foot Throttle Calibration	3-18
Vehicle Settings Page 4:	
Suspension Calibration	3-19
Vehicle Settings Page 5: ET AutoFold (If Equipped)	3-20
Calibrate AutoFold Feature	3-20
Vehicle Settings Page 6: Configuration	3-22
Light Buttons and Adjustable Powered Mirrors	3-23

Apache Sprayer Lighting	3-24
AM/FM Radio with Weather Band and Streaming Player	3-25
Accessories	3-25
Seat Adjustment	3-26
Joystick and Universal Terminal Console	3-27
Starting and Stopping the Engine	3-28
Starting	3-28
Warm-up	3-29
Stopping	3-29
Apache Sprayer Direction and Speed	3-30
Neutral	3-30
Forward	3-31
Shifting Forward Gears	3-31
Reverse	3-32
Foot Throttle/Decelerator	3-32
Exhaust Braking	3-33
Cruise Control	3-34
Towing	3-36
Hood Tilt Latch	3-37
Battery	3-37
The Cabin Power Distribution Module	3-38
The Chassis Power Distribution Module	3-38
Axle Adjustment (optional)	3-39
Manual	3-39
Front	3-39
Rear	3-39
Adjust On The Go	3-40
Adjust-On-The-Go Calibration	3-41
Front Axle	3-41
Rear Axle	3-42
Vehicle Dynamics	3-42
Climate Controls	3-43
Precision Equipment	3-44
Antenna Mounting Plate	3-44
Rear Camera	3-45
Jump-starting the Engine	3-46
Exhaust Cleaning	3-48
Automatic Cleaning	3-48
Disabled Mode	3-49
Manual Cleaning	3-50
Low DEF Fluid	3-51
Boom Rack	3-54
Rack Lock	3-54
Rack Leveling (Manual)	3-56
Rack Leveling (Auto Level)	3-56
Rack Manifold Cleanout	3-56
Rack Angle Calibration	3-57

Chapter 4: Wet System Operation

Wet System Overview 4-1
 Fill Station - 2 IN Valve 4-2
 Key Pad Functions 4-3
 Electric Valve Operation 4-3
 Fill Station - 3 IN Valve with Front Fill 4-4
 Electric Valve Operation 4-5
 3 IN Front Fill 4-5
 Button Feature Decal 4-5
 Touch Screen Controls 4-6
 Touch Screen and Keypad Summary 4-6
 Product Pump and Valves 4-8
 Sump Valve 4-8
 Flow Control 4-8
 Electronic Boom Valves 4-9
 Viper® 4+ Monitor 4-9
 Side Console 4-10
 Joystick 4-10
 Filling Product Tank 4-11
 Tank Fill Monitor (optional) 4-11
 Product Tank Sight Gauge 4-13
 Filling Rinse Tank 4-14
 Hand Rinse (if equipped) 4-15
 Operating Booms 4-16
 Tilt to Remove Boom from the Cradle 4-16
 Unfold Boom Wings 4-16
 Unfold Boom Tips 4-17
 Height Adjustment 4-17
 Tilt to Level Boom 4-17
 Fold Boom Tips 4-18
 Fold Boom Wings 4-18
 Tilt to Return Boom to Cradle 4-18
 AutoFold (If Equipped) 4-19
 Unfold 4-19
 Fold 4-20
 Spraying 4-21
 2 Inch Fill 4-21
 3 Inch Fill 4-21
 Quick Spray Mode
 (Compatible with Raven Spray
 Control Module Only) 4-24
 Optional Fence Row Nozzle with Switchbox 4-25
 Flushing Product Tank 4-25
 2 Inch Fill 4-25
 3 Inch Fill 4-26
 Flushing Booms 4-27
 Cleanload Chemical Eductor 4-29
 Startup 4-29
 Loading Liquid or Powdered Chemical
 into Hopper 4-29
 Boom Recirculation (Optional Equipment) 4-30
 Operation 4-30
 Required Conditions for Recirculation 4-31
 Auto-Recirculation 4-32
 Setup (Raven Boom Recirculation Specific) 4-32
 What To Expect While Recirculation Is Active 4-33

Setup (AgLeader Rightspot Boom Recirculation
 Specific) 4-34

Chapter 5: Lubrication and Maintenance

Maintenance Precautions 5-1
 Environmental Precautions 5-3
 Non-Apache Equipment Maintenance 5-3
 Cleaning Guidelines 5-4
 Mechanical Parts 5-4
 Electrical Parts 5-4
 Body and Cab Exterior 5-4
 Apache Sprayer Service Interval Chart 5-5
 Before Initial Use 5-7
 After First 10 Hours 5-7
 Adjust Boom 5-7
 As Required 5-10
 Daily 5-10
 Grease Boom 5-11
 Flush Wet System 5-13
 Check Tire Pressure 5-13
 Check Engine Oil Level 5-13
 Check Cooling System 5-14
 Check Transmission Oil Level 5-15
 Check Hydraulic Fluid Level 5-15
 Re-Phase Steering Cylinders 5-16
 Drain Primary Fuel Filter 5-16
 Every 40 Hours 5-17
 Adjust Poly Tank Straps 5-17
 Torque Lug Nuts 5-17
 Grease Rear Suspension 5-17
 Grease Front Axle Assembly 5-18
 Grease Axle Components (adjustable only) 5-19
 Grease Rod End - Fixed Axle 5-19
 Check Differential Fluid Level 5-20
 Check Differential for Leaks 5-20
 Check Final Drive Fluid Level 5-20
 After First 100 Hours 5-22
 Every 100 Hours 5-23
 Grease Driveline Components 5-23
 Torque Axle Extension Brace Bolts 5-24
 Every 250 Hours or Yearly 5-25
 Clean or Change Engine Primary Air Filter 5-25
 Change Differential Fluid 5-26
 Change Hydraulic Fluid Filter 5-26
 Every 500 Hours or Yearly 5-27
 Change Primary Fuel Filter 5-27
 Change Secondary Fuel Filter 5-27
 Inspect Front Accumulator and
 Suspension Cylinder 5-28
 Check Accumulator Charge 5-28
 Check Rear Suspension Cylinder,
 Accumulator and Charge 5-29
 Change Engine Oil and Filter 5-32
 Change Transmission Oil and Filter
 and Clean Strainer 5-34

Inspect and Repack Wheel and Inter-Flex Bearings	5-35
Change Final Drive Fluid	5-36
Change Cab Charcoal Filter	5-37
Every Year	5-38
Measure and Adjust Toe-In (Standard 120" Axles)	5-38
Measure and Adjust Toe-In (120" to 160" Adjustable Axles)	5-39
Change Engine Safety Air Filter	5-41
Winterize Wet System	5-42
Every 1000 Hours or Yearly	5-44
Change Hydraulic Fluid	5-44
Change DEF Suction Filter	5-45
Every 4500 Hours or 3 Years	5-46
Change DEF Supply Module Filter	5-46

Chapter 6: Torque Value Charts

Fittings	6-1
Bolts	6-3

Chapter 7: Troubleshooting

Apache Sprayer Troubleshooting Symptoms and Solutions	7-1
--	-----

Chapter 8: Electrical System

Chassis Power Distribution Module and Relay Chart	8-1
Cabin Power Distribution Module and Relay Chart	8-2
Boom Power Distribution Module and Relay Chart	8-2

Chapter 9: Warranty

Apache Sprayer Warranty Registration and Policy For all 2025 Model Year	9-1
--	-----

Chapter 10: Maintenance Log

APACHE™

CHAPTER 1

GENERAL INFORMATION

The graphics and text in this manual generally describe the AS850 Apache Sprayer. Apache Sprayers differ by model and by optionally installed equipment. Your Apache Sprayer may not exactly match the graphics and/or text descriptions in this manual. Please contact your dealer or Equipment Technologies with any questions regarding this manual, or the instructions within it.

2025 AS850 Specifications

	AS850
Tank Capacity	800 gallons [3030 liters]
Engine	Cummins Performance Series V, 200 hp
Transmission	JCB Power shift 4-speed, torque converted
Speed Ranges	1st 0-5 mph [0-8.04 km/h] 2nd 0-9 mph [0-14.5 km/h], 3rd 0-16 mph [0-25.7 km/h] 4th 0-28 mph [0-45 km/h]
Brakes	Internal, wet disc self-adjusting
Suspension	Front Axle: Center oscillation with independent hydraulic, accumulated struts. Rear Axle: Patented hydraulic load suspension with compensating anti-sway control, self-adjusting for diminishing/increasing load.
Cab	ET custom pressurized cab
Crop Clearance	42 in. [106.6 cm] or 50 in. [127 cm]
Axles	120 in. [304.8 cm] Fixed Width Axle (Standard) 120 to 160 in. [304.8 to 406.4 cm] Adjustable Axle Width with Optional Hydraulic Adjust (50 in. clearance only)
Final Drive	JCB planetary gearset (42 in. [106.6 cm] CC); JCB all gear drop box (50 in. [127 cm] CC)
Weight	20,300 lbs [9,208 kg]
Fuel Capacity	90 gallons [340.69 liters]
Width	13 ft [4.0 m]
Length	24 ft [7.3 m]
Height	144 in. [365.7 cm]
Wheel Base	15 ft [4.6 m]
Turning Radius	20 ft [6.1 m]
Standard Tires	Front: 380/80R38 and Rear: 380/90R46
Booms	90 ft [27.4 m], 100 ft [30.4 m], 120 ft [36.6 m], 132 ft [40.2 m], 60/90 ft [18.2/27.4 m]
Boom Height	18 to 89 in. [45.6 to 226.1 cm] (42 in. [106.6 cm] CC); 26 to 97 in. [66 to 246.4 cm] (50 in. [127 cm] CC)
Product Pump	ACE 205F-HYD-304, hydraulically driven centrifugal pump
Rotoflush	Pump pressured

Apache AS850 Fluids, Filters and Capacities

Component	Lubrication	Capacity	Filter Part Number
Engine Oil	Lucas 15W-40 Magnum Motor Oil	16 quarts [15 liters]	201450241
Engine Coolant	Fleetguard ES Compleat OAT Nitrite Free	24 quarts [22.7 liters]	----
Engine Primary Air Filter	----	----	230512001
Engine Safety Air Filter	----	----	230512002
Transmission	Lucas Universal Motor Oil	16 quarts [15 liters]	300000101
Differential (Rear Axle)	Lucas Universal Hydraulic Fluid	11.9 quarts [11.26 liters]	----
Planetary	Lucas 80/90 Gear Oil	2.9 quarts [2.7 liters]	----
Rear Drop Box	Lucas 80/90 Gear Oil	21 quarts [20 liters]	----
Park Brake Oil	Cat® TDTO 30 Transmission and Drive Train Oil	14.5 Ounces [428.8 Milliliters] initial fill*	----
Engine Fuel	Diesel	90 gallons [340.69 liters]	Primary: 261000003 Secondary: 211000000
Diesel Exhaust Fluid (DEF) Supply Module Filter	----	15 gallons [56.8 liters]	241000009
Hydraulic System	Lucas Universal Hydraulic Fluid	23 gallons [87 liters]	880000026
A/C System	R134a	2.8 lbs	----
Charcoal Filter	----	----	490003651

NOTE: Any oil and fluid substitutions must meet or exceed recommended fluid specifications.

* Please see park brake oil fill/ check procedure.

Michelin Tire Pressure (Cold)

380/80R38 (Agribib)35 psi [2.4 bar]

380/80R38 (Spraybib)25 psi [1.7 bar]

380/90R46 (Spraybib)46 psi [3.2 bar]

Lug Nut Torque

All Wheels420 lb-ft [570 N•m]

Wet System Capacities

Product Tank AS850800 gallons [3030 Liters]

Rinse Tank100 gallons [379 Liters]

Hydraulic Pump Output2400 psi [165 bar]

APACHE™

CHAPTER 2 SAFETY

Apache is committed to the safe design and operation of its products. This Apache Sprayer has been designed and manufactured with your personal safety while operating this Apache Sprayer as a primary concern.

Safety Symbols, Signal Words and Statements

Safety symbols, signal words and statements, and symbols are used in this manual and on the Apache Sprayer to identify and alert you of potential hazards where personal safety precautions are required.



The safety alert symbol is used to alert you of potential personal injury hazards. Carefully read the safety message associated with safety symbol and follow any instructions provided to ensure your safety.

Safety signal words are used to alert you of potential personal injury hazards. Carefully read the safety message associated with safety signal word and follow any instructions provided to ensure your safety.

Safety statements are used to explain and inform you of potential personal injury hazards and provide precautionary instructions. Read, understand and follow

all safety messages and information contained in this manual and on the Apache Sprayer to prevent personal injury and ensure safe reliable Apache Sprayer operation.

 **DANGER**

Indicates a hazardous situation which, if not avoided, will result in death or serious injury.

 **WARNING**

Indicates a hazardous situation which, if not avoided, could result in death or serious injury.

 **CAUTION**

Indicates a hazardous situation which, if not avoided, could result in minor or moderate injury.

*The italicized **NOTICE**, indicates a potentially hazardous situation which, if not avoided, may result in improper Apache Sprayer operation and/or damage to equipment, property and the environment.*

Safety Precautions

There is no substitute for common sense and following careful operation and service practices. Improper practices and carelessness can cause personal injury or even death.

The following safety precautions and guidelines must be followed in addition to the specific safety precautions listed throughout this manual and on the Apache Sprayer to reduce the risk of personal injury.

Keep this manual and all included literature in a safe and convenient location. Contact your Apache dealer or Apache at (800) 861-2142 to obtain replacement owner's manuals and safety decals.

To ensure your safety, the safety of others, and the safe operation of the sprayer, read, follow and practice the following:

WARNING

The safety messages that follow have WARNING level hazards.

Pre-Operation Hazards

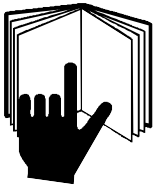

Read and understand this Owner's Manual before operating or servicing the Apache Sprayer to ensure that safe operating practices and maintenance procedures are followed. If you do not understand any part of this manual and need assistance, see your Apache dealer for assistance.

- ***NEVER permit anyone to operate the Apache Sprayer without proper training. Obtain proper knowledge and training before attempting to perform any operation or service procedure in this manual.***
- ***This Apache Sprayer and its attachments are designed to spray liquid product. Use of this Apache Sprayer in any other manner other than its intended use is prohibited.***
- ***DO NOT operate sprayer on public highways with fluid in product tank.***
- ***Remove or clean contaminated clothing before entering the cab.***
- ***Some components and systems of Apache Sprayers are manufactured by companies other than Apache and have specific safety, inspection, adjustment and maintenance procedures outlined by their manufacturer. Carefully read and understand all non-Apache Sprayer and sprayer manufacturer instructions and manuals supplied with the Apache Sprayer. These include, but are not limited to the Engine Owner's Manual, Sprayer Monitor System Manual, Radio Manual, Chemical Eductor Manual, Product Pump Instructions and other optional equipment.***

Fire and Explosion Hazards



Diesel fuel is flammable and explosive under certain conditions. Store any containers containing fuel in a well-ventilated area, away from any combustibles or sources of ignition.

- ***NEVER use a shop rag to catch spilling fuel.***
- ***Wipe up all fuel spills immediately.***
- ***NEVER refuel with the engine running.***
- ***ALWAYS have appropriate safety equipment available. Have all fire extinguishers checked periodically for proper certification, operation and/or charge capacity.***
- ***ALWAYS read and follow safety-related precautions found on containers of hazardous substances like parts cleaners, primers, sealants and sealant removers.***

Burn Hazards



Some of the engine surfaces become very hot during operation and shortly after shut-down. Keep hands and other body parts away from hot engine surfaces.

Lifting Hazards

- *ALWAYS use lifting equipment with sufficient capacity to lift the Apache Sprayer or equipment.*
- *If transport is needed for repair, acquire assistance when using a hoist and when loading and unloading.*

Exposure Hazard

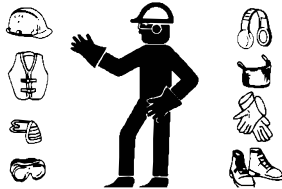

ALWAYS wear the appropriate personal protective equipment as required by the task at hand, including but not limited to:

- *Relatively tight and belted clothing*
- *Safety gloves*
- *Safety shoes/boots*
- *Safety eye glasses/goggles/shields*
- *Hearing protection, ear plugs*
- *Head protection, hard hats*
- *ALWAYS wear a respirator, goggles and gloves in addition to wearing long shirt sleeves and long pants when handling chemicals. Read the chemical safety label or instructions before usage.*

Entanglement / Sever Hazard



NEVER wear jewelry, watches, unbuttoned cuffs, ties or loose-fitting clothing and ALWAYS tie long hair back when working near moving/rotating parts.

- *ALWAYS Keep hands, feet, hair and clothing away from all moving/rotating parts.*
- *NEVER operate the engine without the guards in place.*



Alcohol and Drug Hazard

- *DO NOT operate or service the Apache Sprayer while under the influence of alcohol, awareness-altering drugs or medications that would affect your ability to operate or maintain the sprayer safely.*

Exhaust Emissions Safety

Carefully read all safety information and observe any exhaust or pollution safety instructions. Be aware of and follow all regulations and policies as outlined by the engine OEM to maintain exhaust emission compliance with the Environmental Protection Agency (EPA), California Air Resources Board (CARB) and Environment Canada where applicable.

It is the owner's responsibility to keep the Apache Sprayer maintained and within compliance.

The state of California, U.S., has special regulations that may exceed the EPA regulations. If the Apache Sprayer is operated or serviced in the state of California, observe all exhaust and pollution regulations.



WARNING! Exhaust Gas Exposure Hazards

- **All internal combustion engines create carbon monoxide gas during operation and special precautions are required to avoid carbon monoxide poisoning. Prolonged exposure to carbon monoxide will cause brain damage or death.**
- **ALWAYS operate the engine outside in a well-ventilated area.**
- **NEVER block windows, vents or other means of ventilation if the engine is operating in an enclosed area.**
- **ALWAYS ensure that all connections are tightened to specifications after repair is made to the exhaust system.**

Environmental Precautions

The safety messages that follow have NOTICE level hazards.

- Thoroughly clean any spilled fluids from the equipment and/or ground after service is completed. Dispose of used fluids and filters as required by law.
- ALWAYS be environmentally responsible. Follow the guidelines of the EPA or other governmental agencies for the proper disposal of hazardous materials such as engine oil, diesel fuel and engine coolant. Consult the local authorities or reclamation facility.
- NEVER dispose of hazardous materials by dumping them into a sewer, on the ground, or into ground water or waterways.

Safety Belt



WARNING! Impact Hazards.

- **ALWAYS fasten your seat belt when operating the Apache Sprayer. The safety belt must be worn properly by the driver anytime the Apache Sprayer is in motion.**
- **NEVER alter or tamper with any safety belt system components.**

Safety belt systems are designed to limit occupant motion by restraining occupants' bodies within the cab and prevent, or reduce the severity of, injuries during most types of collisions. When safety belts are used properly, they are effective in reducing the risk of injury.

Inspect the safety belt system regularly for cuts, frays, wear, discoloration or abrasion. The hardware, mounts, retractor and belt should work freely. The belt and/or components must not show signs of deterioration. If you suspect any part of the system is in need of repair, have the system repaired or replaced immediately and use only parts designed for the safety system.



WARNING! Impact Hazard

DO NOT operate the Apache Sprayer if any part of the seat belt system is damaged. The system must be repaired or replaced before operating the Apache Sprayer.

NOTICE: DO NOT use harsh cleaners, bleach or any products which could cause the safety belt material to deteriorate.

Safety Decals



CAUTION!

ALWAYS read and follow the safety decals on the Apache Sprayer. Safety decals are additional reminders for safe operating and maintenance techniques.

Safety decals are used to explain and inform you of potential personal injury hazards and provide precautionary instructions. Read, understand and follow all safety decals on the Apache Sprayer to prevent personal injury and ensure safe reliable Apache Sprayer operation.

NOTICE: Prevent safety decals from becoming dirty or damaged and replace them immediately should they become damaged or are missing. Should an Apache Sprayer part that has a decal attached to it need replacement, obtain a new decal with the new part.

Contact your Apache dealer or Apache at (800) 861-2142 to obtain replacement safety decals.

To ensure your safety, the safety of others and the safe operation of the sprayer, read, follow and observe the following safety decals.

Decal Locations

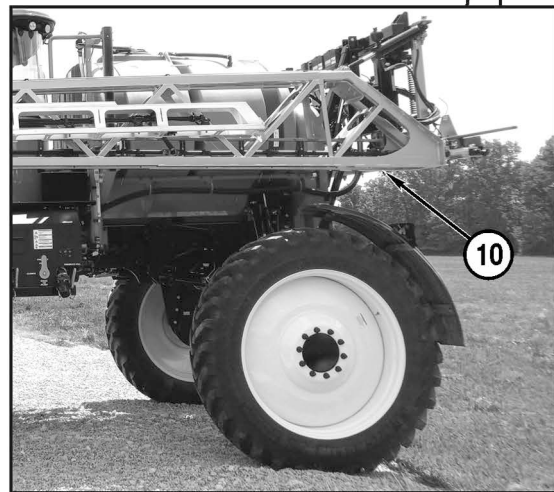
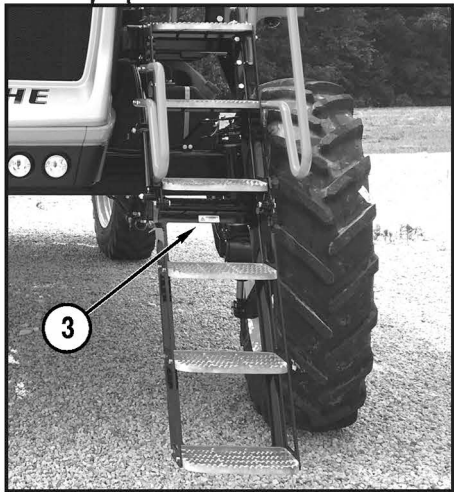
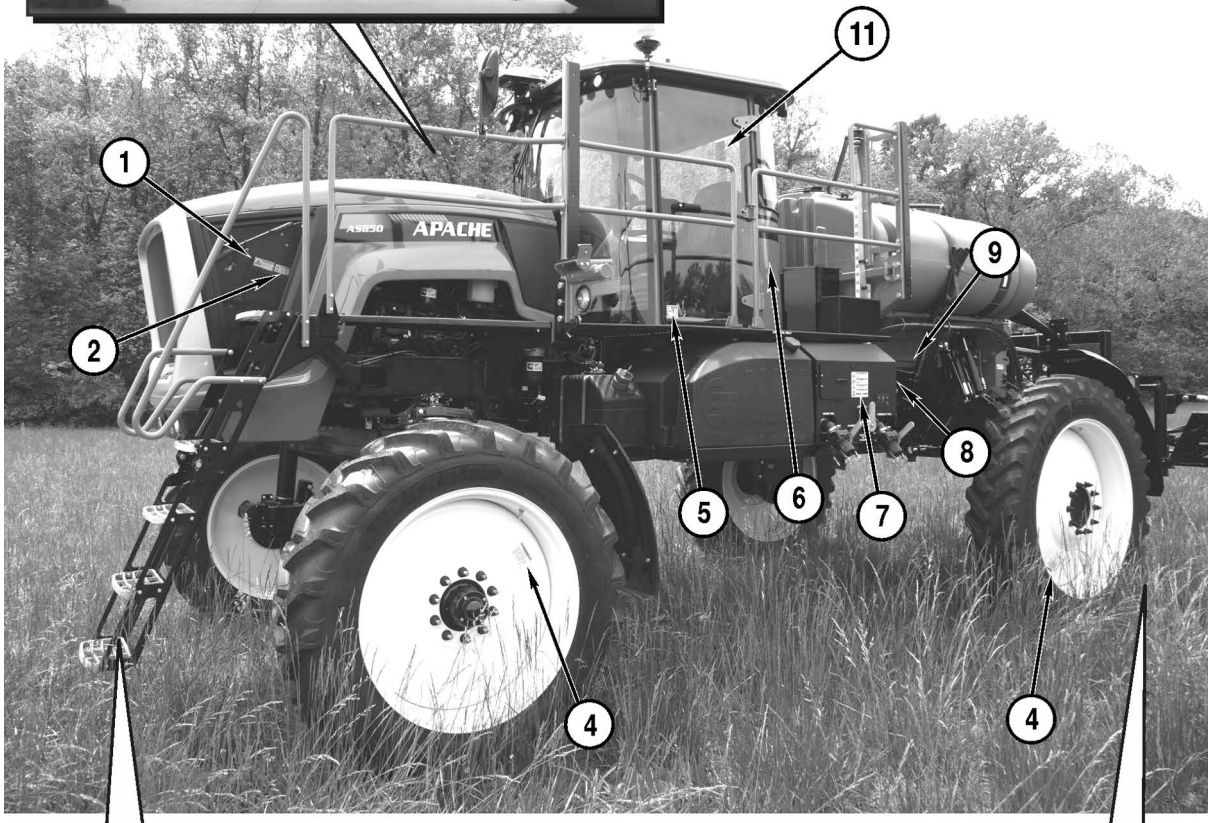
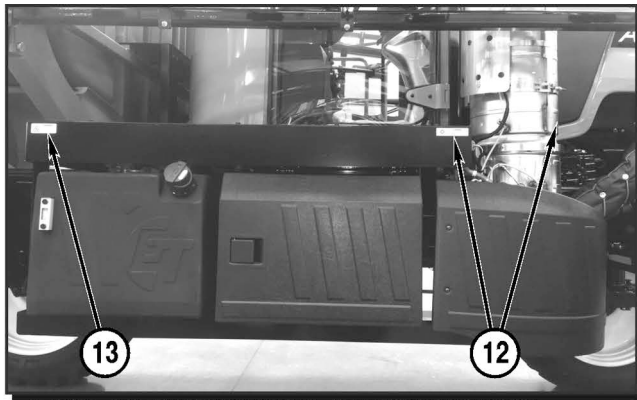

Decal Locations (continued)

1.  **WARNING**
BURN / SEVER HAZARD
 Keep fingers clear of hot surfaces and rotating parts while engine cover is open and engine is running.
 420306036

2.  **WARNING**
ROTATING FAN BLADES
 • Keep clear while engine is running
 • Contact may result in personal injury or death
 472000037

3.  **WARNING**
STRIKING BYSTANDER HAZARD
 Keep bystanders away from automatic ladder; it may move unexpectedly.
 420306059

4. **WARNING**
TIRE HAZARD
 • Torque wheel bolts to 420 ft-lb (570 N•m). Check torque daily for first week of operation and weekly thereafter.
 • Replacement tire must meet or exceed original tire specifications. Failure to comply may cause tire failure resulting in serious injury or death.
 420306033





6.  **WARNING**
 Never climb inside tank
 472000028

 **NOTICE**
 1. Tighten bolts on each tank strap without pulling the top of the tank down or bending the bolts or tank skid.
 2. Tighten tank straps evenly side-to-side.
 3. Fill the tank with water.
 4. Drive tractor.
 5. Allow tank to settle.
 6. Retighten straps.
 7. Inspect straps daily.
 472000027

7.  **WARNING**
HIGH-PRESSURE FLUID HAZARD
 High-pressure hydraulic fluid leaks can penetrate skin resulting in serious injury, gangrene or death.
 • Check for leaks with cardboard; never use your hand.
 • Before you loosen a fitting:
 - Lower load.
 - Release pressure.
 - Make sure hydraulic fluid is cool.
 • Consult physician immediately if skin penetration occurs.
 420306013

 **WARNING**
EXPOSURE HAZARD
 Agricultural chemicals can be dangerous:
 • Improper selection or use can seriously injure persons, animals, plants, soil or other property.
 • Select the correct chemical for the job.
 • Handle the chemicals with care.
 • Follow the instructions on the container label and instructions from the equipment manufacturer.
 420306018

 **WARNING**
NON-POTABLE WATER HAZARD
 This water is for rinsing or washing purposes only. Do not drink it. It may be contaminated by sprayer chemicals. Fill with clean water only.
 420306032

 **WARNING**
ENTANGLEMENT HAZARD
 Keep body parts away from rotating driveshaft.
 420306058









 **NOTICE**
 • Fill the rinse, foamer or product tank slowly.
 • Rapidly filling, or overfilling, any of these tanks may cause them to rupture.
 420306048

8.  **WARNING**
BATTERY TERMINAL POSTS HAZARD
 These battery terminals are for low amperage charging and accessory power only. Do not jump or boost machine from terminals.
 472000005

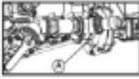

10.  **WARNING**
Crush Hazard
 Can cause serious injury or death.
 Stay clear of moving mechanism
 472000029

Decal Locations (continued)

	<p>⚠ DANGER</p> <p>ELECTROCUTION HAZARD</p> <ul style="list-style-type: none"> • This machine is not insulated. • Death or serious injury will result from contact with or inadequate clearance to electrical power lines and apparatus. • Maintain safe clearances from electrical power lines in accordance with applicable government regulations such as OSHA 1910.269. • This machine does not provide protection from contact with or proximity to an electrically charged power line. <p>420306050</p>
	<p>⚠ WARNING</p> <p>STRIKING OBJECT OR BYSTANDER HAZARD</p> <p>Do not fold or unfold booms while sprayer is moving.</p> <p>420306054</p>
	<p>⚠ WARNING</p> <p>OPERATIONS HAZARDS</p> <ul style="list-style-type: none"> • Do not operate sprayer on public highways with fluid in product tank. • Always drain and flush tank prior to transport. • Do not exceed 40 mph unloaded. <p>420306052</p>
	<p>⚠ WARNING</p> <p>OPERATIONS HAZARDS</p> <ul style="list-style-type: none"> • Read and understand operator's manual before operating, servicing or repairing the tractor. Follow all safety rules and instructions. Manuals are available from dealer. • Only operate tractor from operator's seat with seat belt securely fastened. • Before leaving the operator's seat, place machine in neutral position, apply parking brake, and stop engine. • Do not allow children or untrained persons to operate the equipment. • Reduce speed when turning or operating around hazards, on rough ground or steep slopes. • Use flashing warning lights on highways unless prohibited by law. <p>420306051</p>
	<p>⚠ WARNING</p> <p>FALLING HAZARD</p> <p>Never allow riders outside of the cab while operating machine.</p> <p>420306050</p>
	<p>NOTICE</p> <p>Use a charcoal element when replacing the cab air filter and cab recirculating air filter.</p> <p>(A) Cab Recirculating Air Filter - P/N 420000001 (B) Cab Charcoal Air Filter - P/N 490003651</p> <p>472000007</p>
	<p>NOTICE</p> <ul style="list-style-type: none"> • Do not run product pump (A) dry. Seal damage will occur. • Do not intentionally dead-head the pump with high pressure. Seal damage will occur. <p>472000035</p>
	<p>NOTICE</p> <p>BATTERY DISCONNECT PROCEDURE</p> <ul style="list-style-type: none"> • Wait 120 seconds to disconnect machine battery power post engine shut-down. <p>472000058</p>

	<p>⚠ WARNING</p> <p>BURN HAZARD</p> <p>Keep hands away from the muffler and exhaust system until the engine is completely cool.</p> <p>420306058</p>
---	--

	<p>⚠ WARNING</p> <p>Falling Hazard</p> <ul style="list-style-type: none"> • No guardrails present • Not to be used as walking surface <p>472000031</p>
---	--

	<p>⚠ WARNING</p> <p>Pinch Point</p> <p>Keep hands clear during operation.</p> <p>472000034</p>
---	--

(not shown in image)

	<p>NOTICE</p> <ul style="list-style-type: none"> • Check Torque Every 100 hours of machine operation and adjust as required • See Operator's manual for correct torque values <p>472000030</p>
--	---

(not shown in image)

APACHE™

CHAPTER 3 OPERATION

Before performing any operation procedures, read the following safety messages and read the Safety Section.



WARNING! Control Hazard. DO NOT operate the Apache Sprayer while wearing a headset to listen to music or radio because it will be difficult to hear the warning signals.



WARNING! Impact Hazard. Secure any loose items in cab. Items that are unsecured may cause injury in case of a roll-over.



WARNING! Roll-Over Hazards

- **DO NOT operate on steep slopes.**
- **DO NOT drive across a slope. Drive up and down slopes.**
- **DO NOT turn down a slope.**
- **Slow down when turning.**
- **Keep booms as close to the ground as possible.**
- **Drive slowly across rough ground.**
- **DO NOT operate on public roads or highways with liquid in the product tank.**
- **ALWAYS use 4-way flashers on public roads or highways.**
- **ALWAYS come to a complete stop before reversing directions.**

Pre-Operation Checks

Before operating the Apache Sprayer, perform the following safety and equipment checks.

- Read and understand this manual before operating the Apache Sprayer.
- Read and follow all safety messages and safety decal instructions in this section. See "Safety" on page 2-1. Check the condition of all safety decals. Replace if damaged.
- Check that all shields and guards are properly installed and in good working condition. Replace if damaged.
- Check all hardware for proper installation and torque. See "Torque Value Charts" on page 6-1.
- Check the operating area for bystanders and obstruction before operating.
- Check that all hydraulic hoses and fittings are in good condition and not leaking. Make sure the hoses are routed to prevent damage, not twisted, sharply bent, kinked, frayed, or pulled tight or rubbing, before starting the Apache Sprayer. Replace any damaged hoses or fittings immediately.
- Check the operation and condition of the seat belt. Immediately repair or replace the seat belt if damaged or if it does not operate properly.
- Check tires for proper inflation pressure according to tire manufacturer's recommendations. Specifications are also provided on the back cover of this manual. See "Check Tire Pressure" on page 5-13.
- Check engine oil level and add oil as needed. See "Check Engine Oil Level" on page 5-13.
- Check transmission fluid level and add fluid as needed. See "Check Transmission Oil Level" on page 5-15.
- Check differential, gearboxes and/or planetaries fluid levels and add fluid as needed. See "Check Differential Fluid Level" on page 5-20.
- Check coolant level and add coolant as needed. See the engine manufacturer's manual for details.
- Check hydraulic reservoir fluid level and add fluid as needed. See "Check Hydraulic Fluid Level" on page 5-15.

Cab Overview

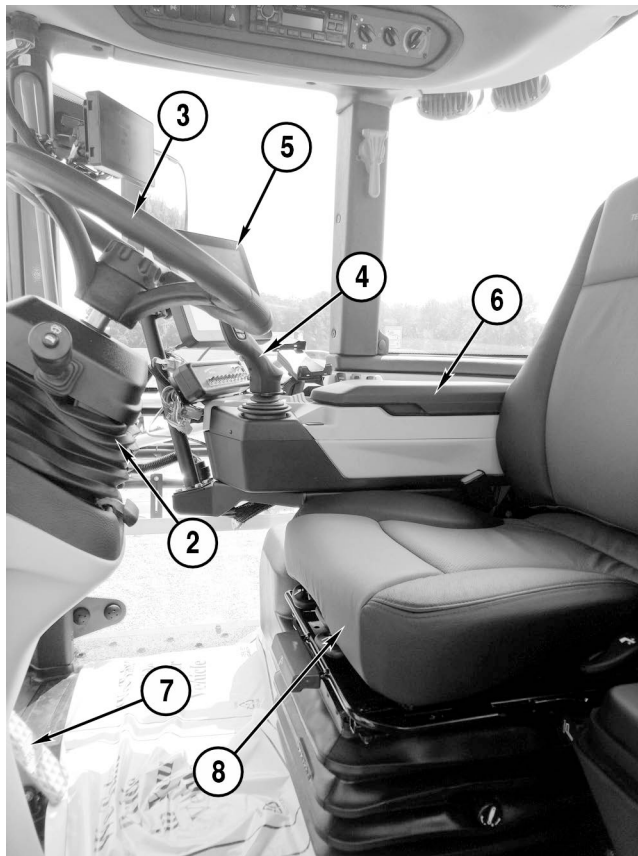

1. **Air vents (not shown)**
(multiple points in the steering column)
2. **Steering Column**
3. **Steering Wheel**
4. **Joystick**
5. **ET Pilot System**
6. **Arm Rest**
7. **Brake Pedal**
8. **Air Seat**
9. **Fire Extinguisher (not shown)**
(left of the driver seat)

Cab Access Ladder

1. Access Ladder

The cab access ladder is automatically actuated by the parking brake switch.

- When the parking brake is applied, the ladder folds down.
- When the parking brake is released, the ladder folds up.



Steering Column

NOTE: DO NOT drill the plastic of the steering column, or alter in any way.

1. Steering Column Tilt Adjustment Lever

- Lift up on the lever.
- Adjust the tilt to the desired position.
- Release the foot lever to lock the column.

2. Steering Wheel

3. Steering Wheel Telescope Adjustment Knob

- Turn center knob counterclockwise to unlock.
- Position steering wheel to desired height.
- Turn center knob clockwise to lock.

4. Horn Button

Push to sound horn.

5. Turn Signal Lever

- Push lever up for right turn signal.
- Push lever down for left turn signal.

6. Windshield Washer

- Push ring to operate washer.

7. Windshield Wiper Switch

- Turn lever to the “I” position for low speed wiper.
- Turn lever to the “II” position for high-speed wiper.
- Turn lever to the “J” position for delay wiper.



ET Pilot System



1. Cruise Control Buttons
2. Product Pump Switch Manual/Auto
3. Manual Product Pump PWM Increase/Decrease Buttons
4. Product Tank Agitation Increase/Decrease Buttons
5. Left Boom Tip Fold Switch In/Out
6. Right Boom Tip Fold Switch In/Out
7. Rack Lock Button
8. Rack Autolevel Button
9. Left Inner Boom Fold Switch In/Out
10. Right Inner Boom Fold Switch In/Out

ET Pilot System

1. Engine RPM and MPH Readout
2. Temperature Gauge
3. Fuel and DEF Gauges
4. Direction and Gear Indicator
5. Engine Hours
6. Scheduled Maintenance Icon
(Appears only when there is Scheduled Maintenance required.)
7. Climate Control Readout
8. High Beams Indicator
9. Date and Time Indicator
10. Cruise Control Indicators
11. General Warning Indicator
12. Engine Fault Indicator
13. Autofold Icon

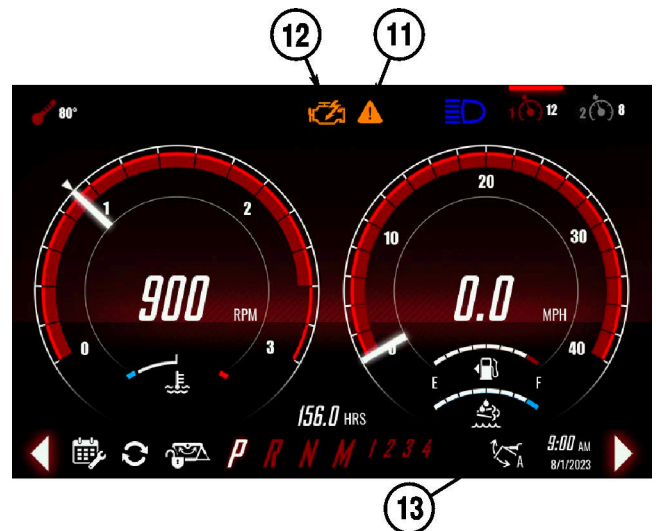
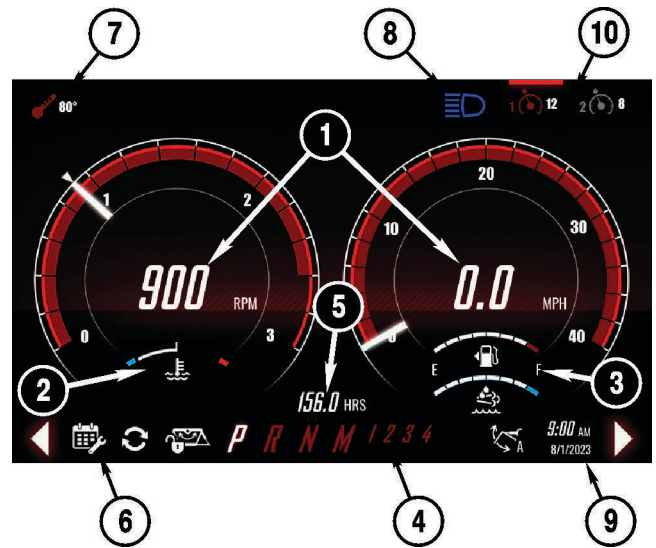

14. High Exhaust Temperature Lamp
15. Exhaust System Cleaning in Progress
16. Exhaust Cleaning Disabled
17. Boom Rack Lock
18. Software Update Icon
19. Turn Signal Indicators

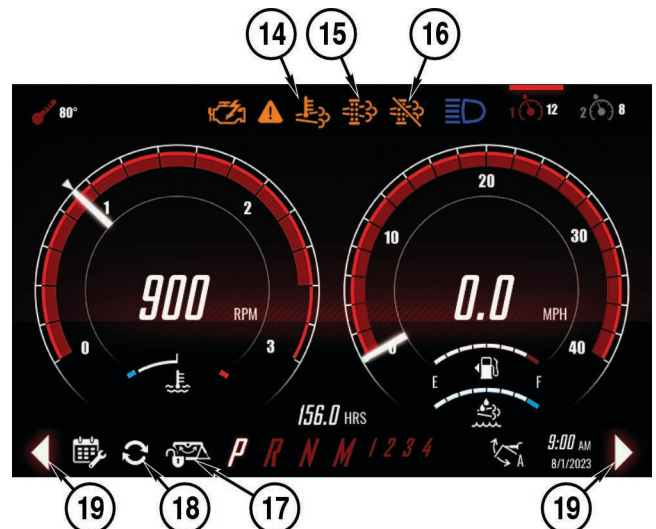

ET Pilot System Touch Screen

To use the screen there are a few things to know.

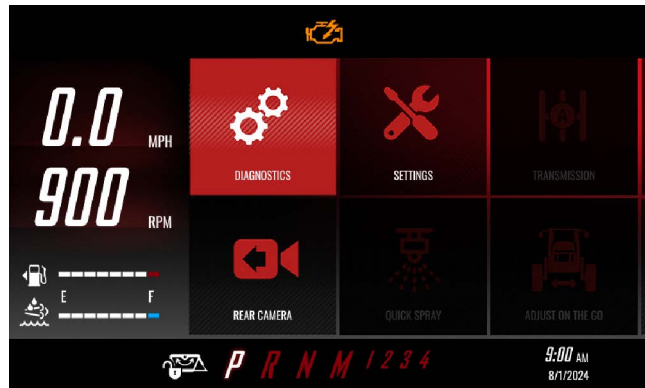

To change the items inside the gauges, touch the RPM or MPH icons (1) to display different options such as:

Average GPH, Torque, MPH and RPM. To move to the App Screen, swipe left, anywhere in the middle of the screen (2) except for inside the gauges (1). (3) is the Date and Time setting.

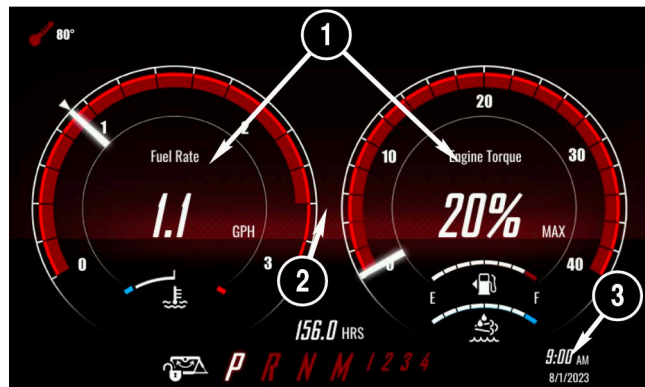

To change the date and time setting, tap the Date and Time indicated by (3) above.

This screen will appear. Use the plus and minus signs to change up or down. Use the Back and Next buttons to move among hours, minutes, date, etc. Cancel to return to the Home Screen.

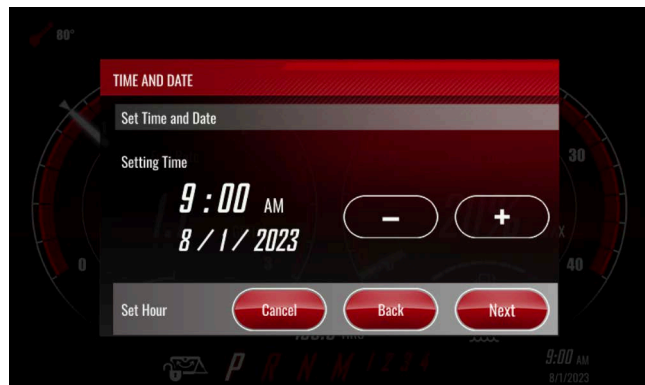

Adjust as needed, then click OK to Save your changes and return to Home Screen.

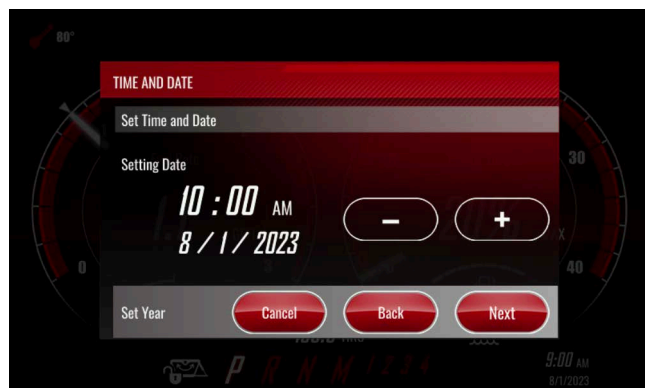

ET Pilot System Touch Screen (continued)

After moving to the App Screen (by swiping left, anywhere in the middle of the home screen, except for inside the gauges) select an App, by touching the desired icon (1) on the screen to move to the selected screen.

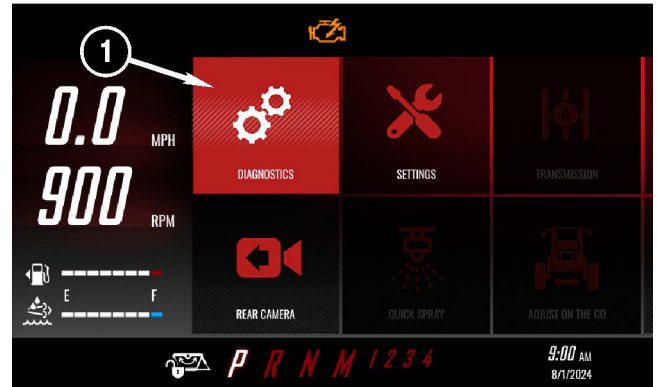

Once in an App screen, there are a few options to choose from. To return to the App Screen, swipe the header bar (1) to the right. To see what page you are within the App, look at the page indicator (2). To move from page to page, swipe left or right in the middle of the screen (3). To scroll the page, swipe the middle of the screen up or down (4).

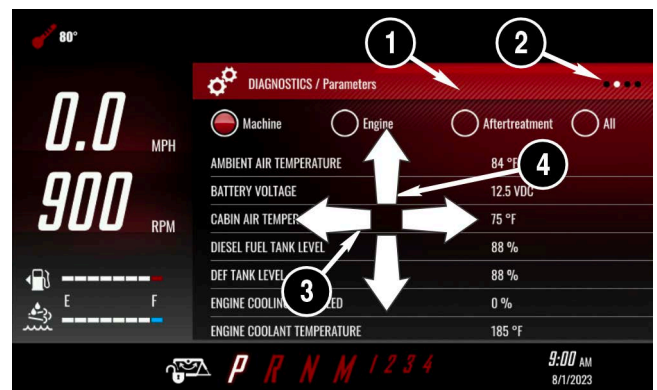

To return to the Home Screen, swipe the screen to the right from the top or the left side (1). This will work on any of the screens.

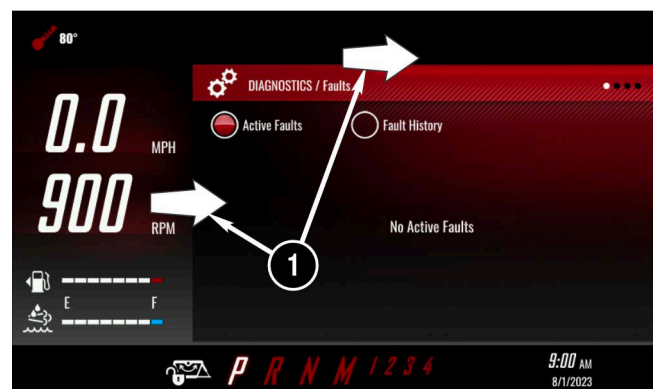

Diagnostics Page 1: Vehicle Warnings

When a new vehicle warning happens, the touchscreen will display a warning screen. It will indicate the fault code (1) and general description of that code (2). Touch the OK icon (3) to close the screen.

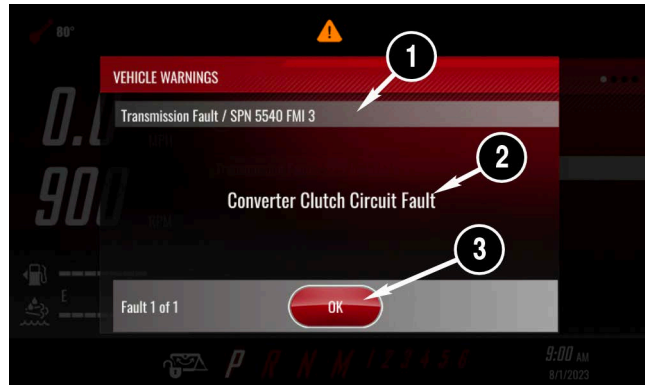

To access the Active Faults screen, either touch the fault indicator (1) at the top of the screen or touch the Diagnostics App icon (2).

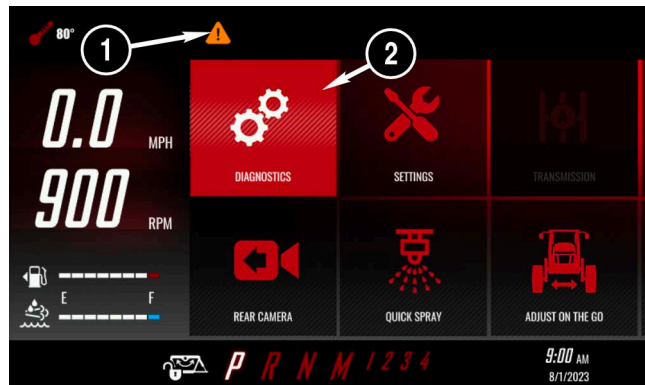

Active Faults

This page will display the option to choose active faults or fault history (1). Choose active faults. Then touch the fault information bar (2) to expand for further detail.

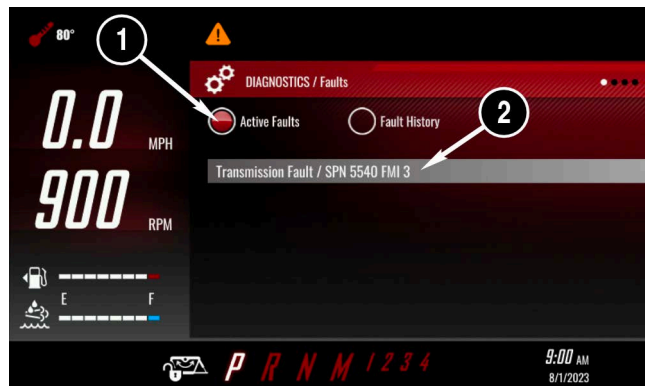

Once the information has expanded, the page will display more detail. This will include the Reason and Effect (1) on the machine.

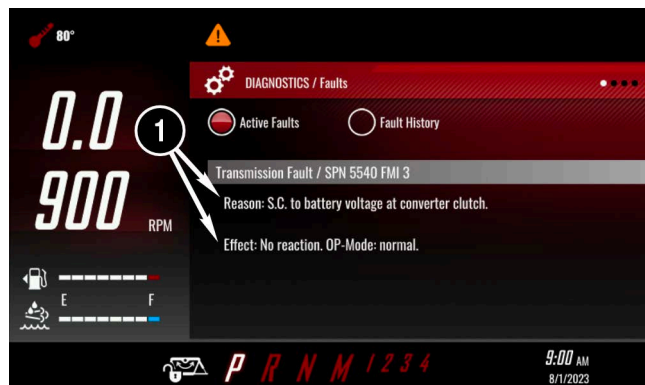

Fault History

This page will display the option to choose active faults or fault history. Choose fault history (1). Then touch the fault information bar to expand for further detail (2). The last hours are shown when the fault was last active (3).

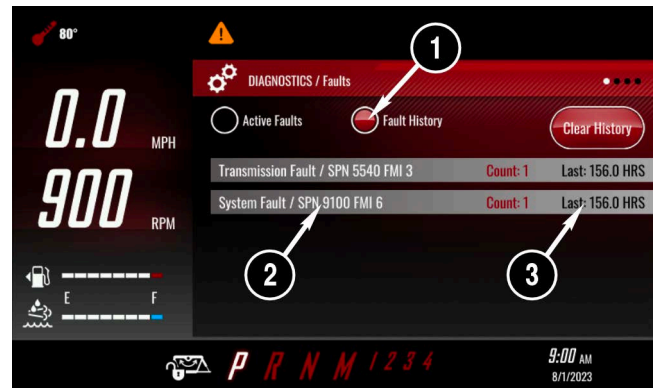

Once the information has expanded, the page will display more detail. This will include the Reason and Effect (1) on the machine.

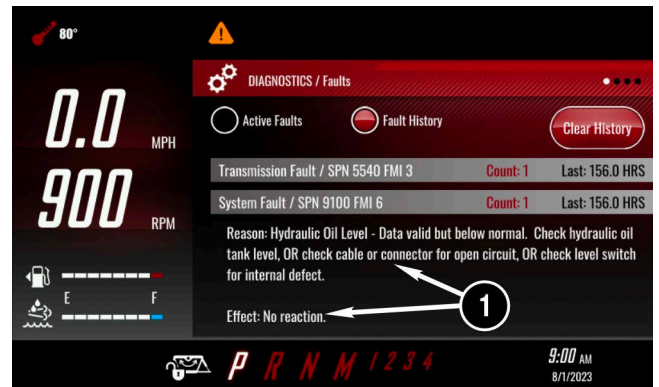

Press the Clear History (1) button to clear all saved history.

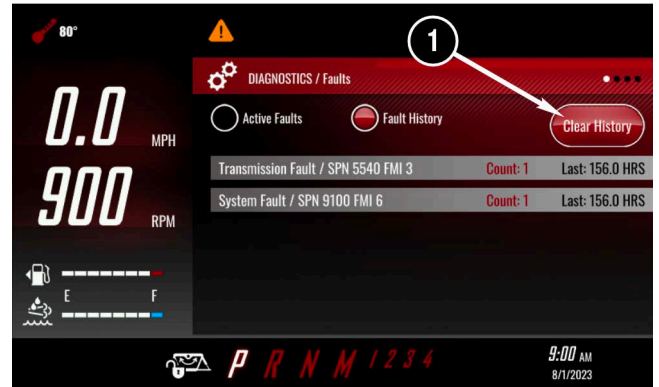

It will then display a prompt (1) to confirm whether or not you would like to clear the history.

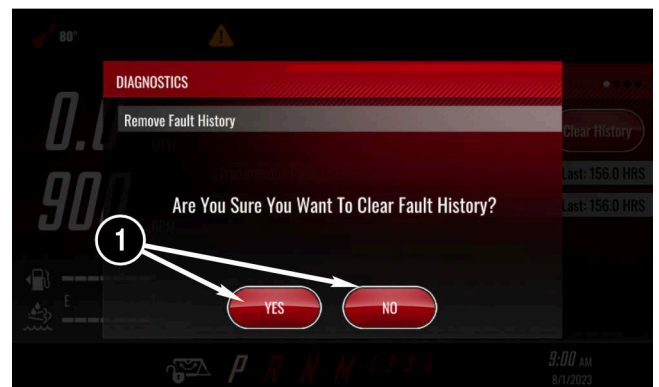

Diagnostics Page 2: Parameters

To filter for Machine Parameters only, select Machine button (1). To filter for Engine Parameters only, select Engine button (2). To filter Aftertreatment Parameters, select Aftertreatment button (3). To view All Parameters select All (4).

To view all the information on that page, swipe the screen up.

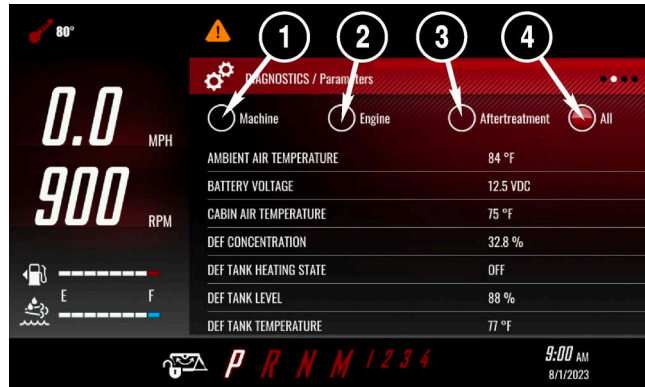

Diagnostics Page 3: Fan Control

The Apache is equipped with a fan reverser. This function can be used to reverse the airflow through the radiator and coolers in order to remove dust and debris.

While the engine is running, touch the icon (1) to turn the fan reverse on. It will run approximately for 20 seconds and then return to normal operation.



The fan reversal has Auto Mode as an option. Touch the icon (1) to activate. Use the slider icon (2) to set how frequent the fan will reverse. The fan reversal can still be manually turned on and off (3) while in Auto Mode.

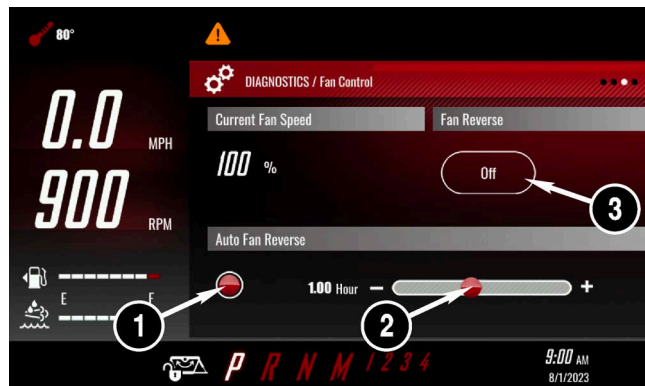

Diagnostics Page 4

Page 4 of the diagnostic app shows a system map diagram. This diagram indicates which ET machine processors are online or offline. A green circle with a ? indicates the processor is online. A red circle with an x indicates a processor is off line. Below are some of the features of the diagnostics app. Individual processors may be viewed after going into the full screen mode. In order to activate the full screen mode the engine must not be running and the park brake must be set.

1. “System Map” indicating which processors are on or off line.
2. “Full Screen” button to allow for more detailed information to be accessed.

Touching the full screen button (2) will bring up the view on the right.

Touching each individual icon in the full screen mode will bring up more detailed information for each processor. For example, when the “Firewall” icon (3) is touched, the “Firewall Box Controller Detail View” will show each processor available on the firewall box and its status. The “System Map” icon will bring up a full screen view of the system map indicating which processors are on or off line.

Engine Control Module Detail View

The ECM view will show the ECM connection status and engine specific information on the left side of the screen and fault code information on the right side of the screen. Touching the fault code buttons will open up more detailed information about each fault code. Fault code history will need to be cleared from the first page of the diagnostic app.

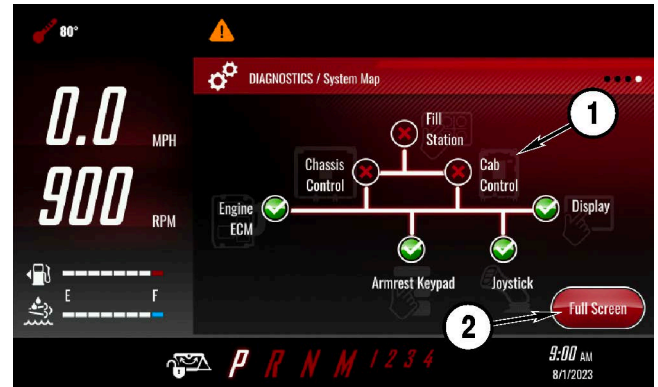

Diagnostics Page 4 (continued)

Chassis Control Detail View

The left side of the screen will show the connection status for each processor that is visible on the firewall box along with the current software version. If a processor is not available (i.e. an AOG processor on a fixed axle machine), then it will be “hidden” from the processor detail menu.

On the bottom left of the screen, fuse/circuit detection faults are seen with the corresponding fuse and relay (if applicable) highlighted on the dynamic display on the right side of the screen. Scrolling the menu on the left side of the screen will bring up more information.

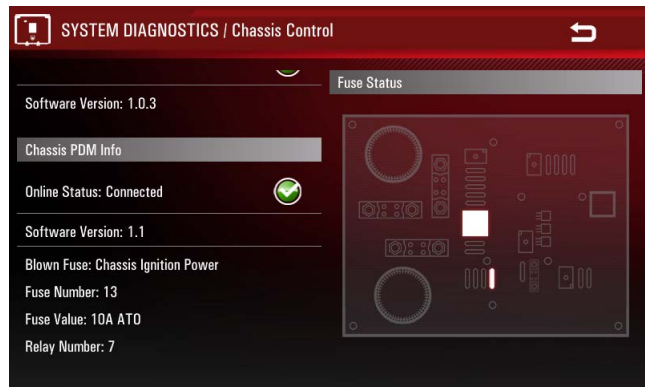

Diagnostics Page 4 (continued)

Cab Board Controller Detail View

On the bottom left of the screen, fuse/circuit detection faults are seen with the corresponding fuse and relay (if applicable) highlighted on the dynamic display on the right side of the screen. Scrolling the menu on the left side of the screen will bring up more information.

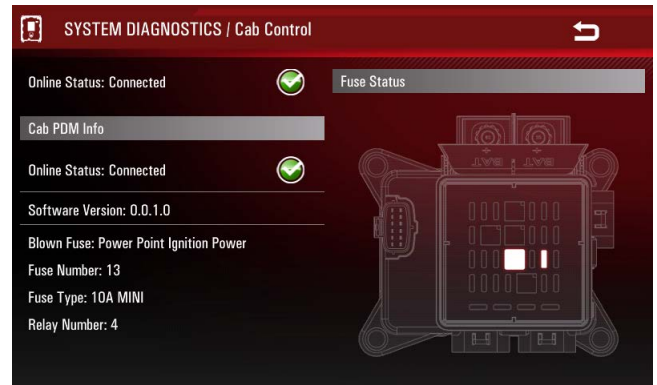

The top left of the screen is a “light button status” window. When pressing one of the buttons on the light pad located on the right wall console, the corresponding button on the diagnostic screen will highlight indicating that the cab board is seeing the signal from the light pad.

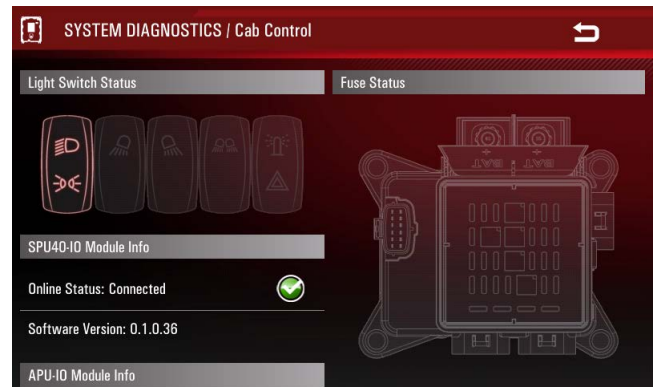

The bottom left of the screen indicates whether or not the cab board processor is online and displays the software version of the cab processor. Fuse/circuit fault detection is also displayed along with highlighting the corresponding fuse and relay (if applicable) on the right side of the screen.

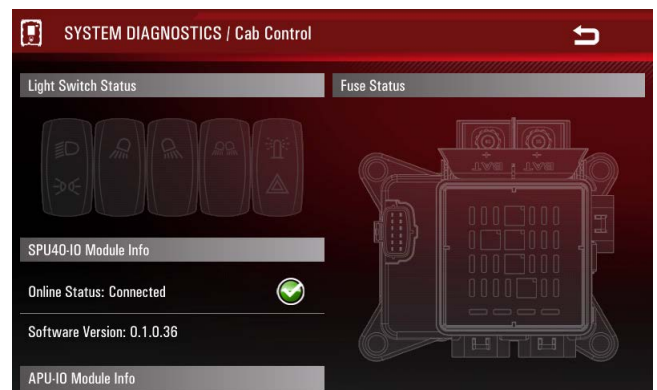

Diagnostics Page 4 (continued)

Armrest Keypad Detail View

The top left side of the screen shows the connection status for the processor. Touching the function buttons on the armrest keypad will highlight the corresponding button on the dynamic display located on the right side of the screen. This will indicate whether or not the button touch is being seen by the CAN circuit.



Joystick Detail View

The top left side of the screen shows the connection status for the joystick processor. The dynamic joystick image on the left side of the screen will highlight button touches made on the joystick touch pad and from the transmission direction switches being pressed. The dynamic joystick image on the right side of the screen will correspond to movement of the joystick along the X and Y axis.



Display Detail View

The left side of the screen shows the connectivity status for the display processor, the Ethernet port, and the USB port. The USB connection status will show whether or not the USB driver on the processor is able to communicate with an installed USB stick (aka thumb drive). The right side of the screen displays fault code information for machine generated faults, not transmission or engine faults. They can be seen on their controller detail views or on the 1st page of the diagnostic app. Press each fault code button to view additional information. Fault code history will need to be cleared from the first page of the diagnostic app.

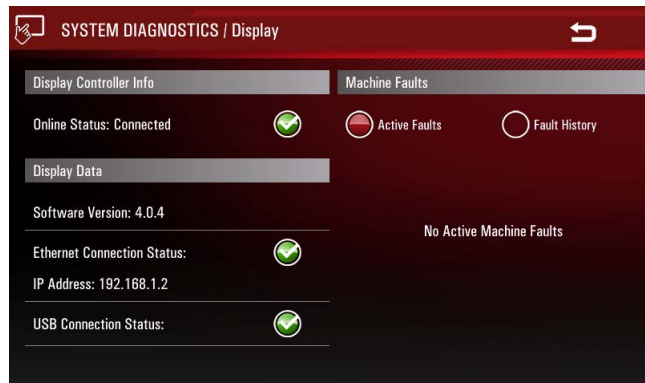

Scheduled Maintenance App

The scheduled maintenance app is used to provide maintenance information and reminders. The app icon is located on the second page of the app menu. (1) This app can also be opened via a maintenance reminder icon on the bottom row (2).

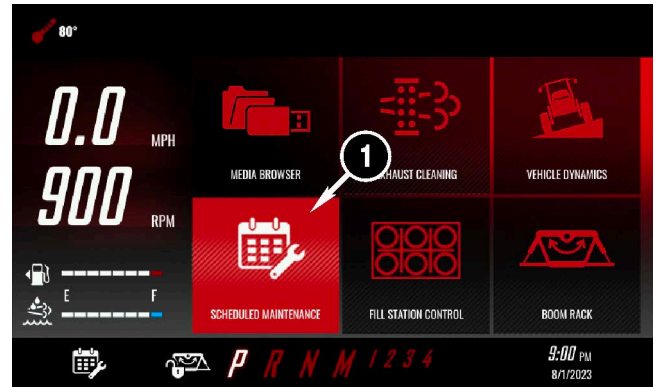

General Maintenance App Page

The first page of the General Maintenance app is a table showing general maintenance items and recommended schedule.

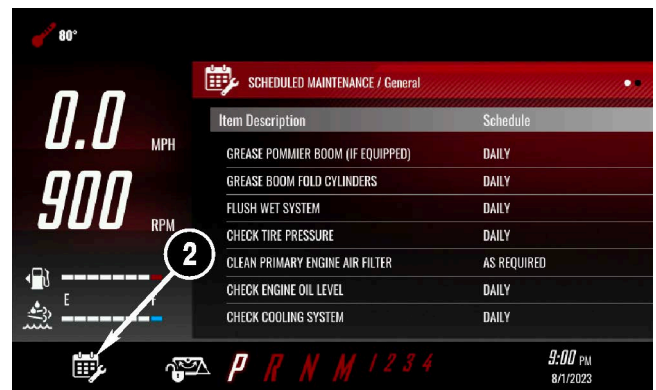

Interval Maintenance App Page

The second page of the app is a list of key maintenance items that run on engine hour based intervals. The lists shows the description, last time performed, and the next required maintenance. The last time performed is initially populated with "N/A", then the next time required is calculated assuming that maintenance was performed on schedule up and to the current engine hours.

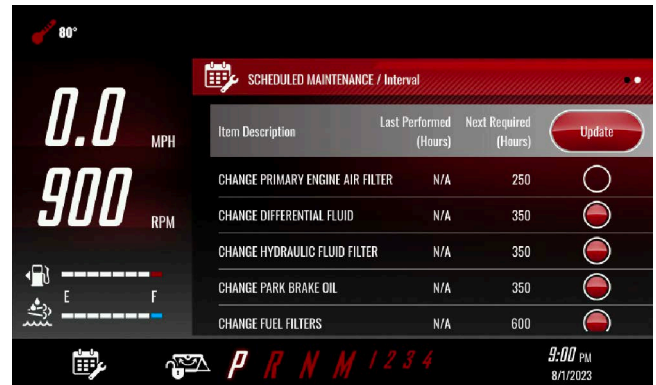

Scheduled Maintenance App (continued)

Maintenance Entry

Alongside each item on the interval maintenance page is a button that allows the user to enter a maintenance event for that item (1).

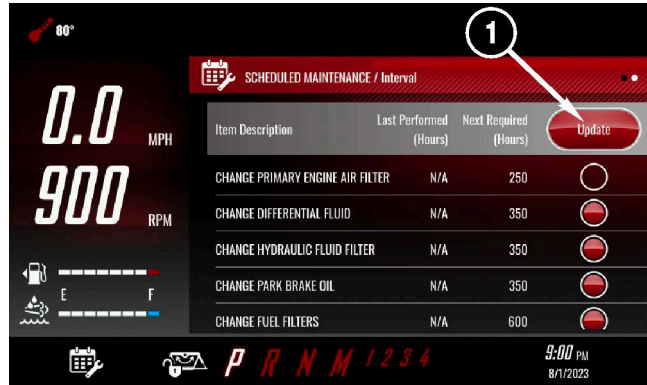

Selecting the entry button opens a dialog that asks the user if they would like to add a maintenance entry for that item description. Selecting Ok opens the screen shown on right as (2). This shows the current engine hours as well as up and down arrows. Click OK to indicate maintenance performed. (or change hours to if needed, then select OK.) Selecting Cancel closes the window and exits to the app page.

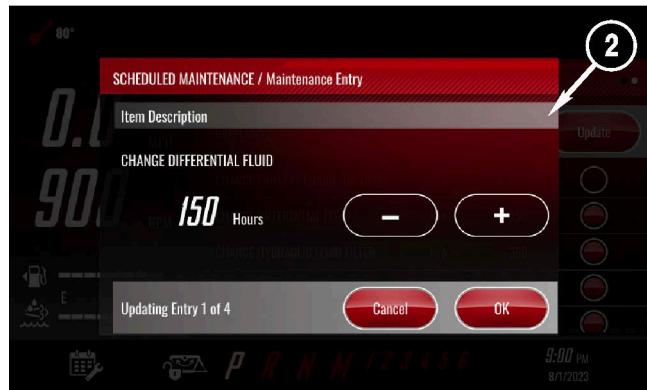

Maintenance Reminders

When required maintenance is within 10 hours of the current engine hours, a maintenance icon is shown (1). Pressing the icon takes you directly to the interval maintenance app page.

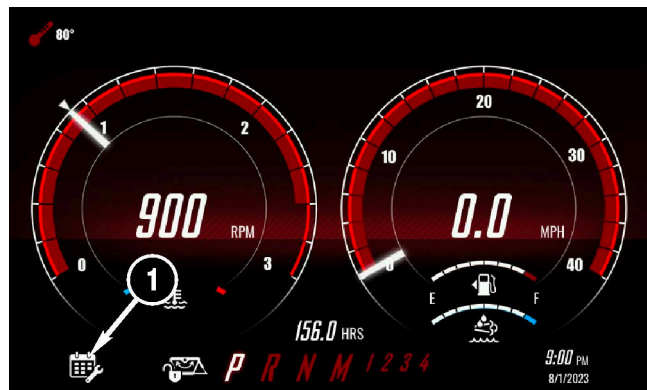

A maintenance reminder pop up is shown whenever there are scheduled items. You must press Ok to clear the screen.

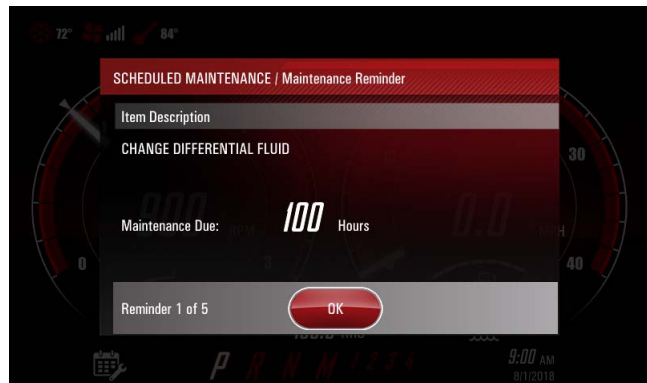

Vehicle Settings Page 1:

To activate these settings, touch the white circle (1). This will allow you to make adjustments to those settings by using the slider (2). Touch the red icon in the slider and swipe left or right to increase or decrease the value. To access the remaining options on this page, swipe the screen up (3).

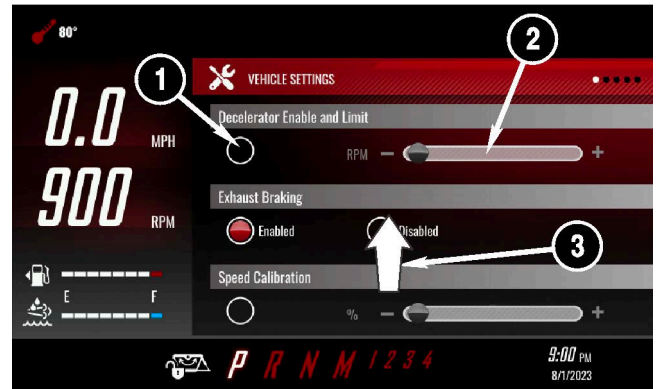

The same applies for this screen. Touch the white circle (1) to activate and use the slider (2) to change the values. Scroll up and down on this page by swiping the screen up (3).

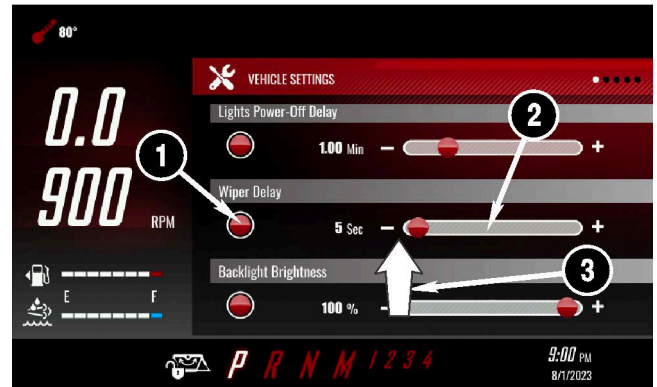

To continue to the next Vehicle Settings page, swipe the screen to the left (4).

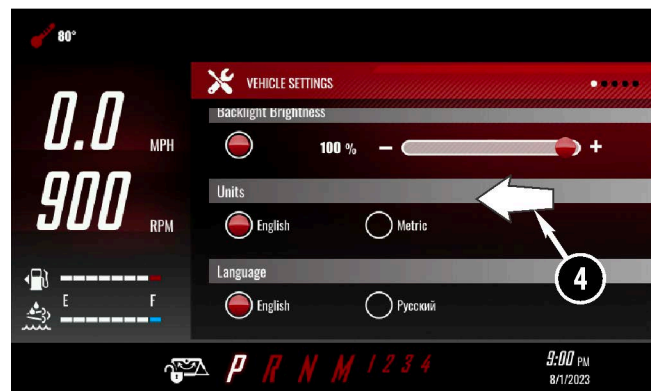

Vehicle Settings Page 2: Version Information

****To be able to continue to the next page, a pass code is needed. This is a warning that the changes that are going to be made, will effect the machine's function.**

Enter the code "2201" by touching the number icons (1). To cancel and return to the previous screen, touch the cancel icon (2). To delete a previous typed number, touch the backspace icon (3).

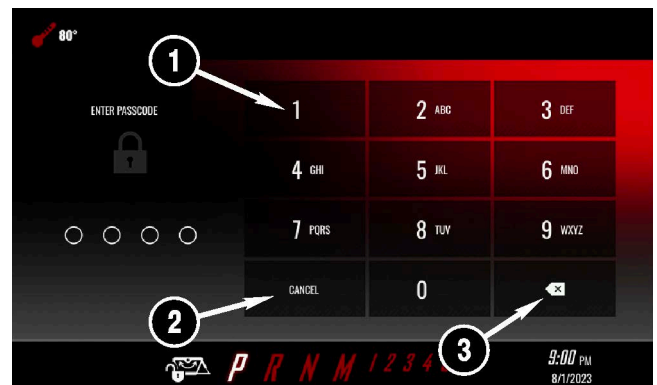

This screen will display the current version of the machines software (1). It will also display the new version if there is a machine software USB drive loaded (2).

Please consult with your dealership about any updates.

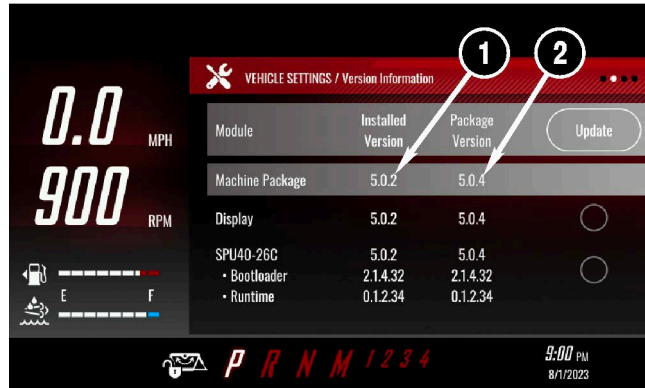

Vehicle Settings Page 3: Foot Throttle Calibration

Calibrating the foot throttle is performed in two steps. Step 1: Depress the foot throttle to the floor. Then touch OK (4) while holding the foot throttle down.

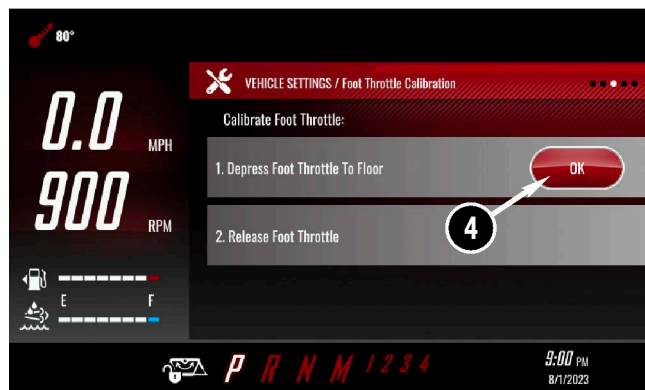

Step 2: Release the foot throttle, then touch OK (5) to complete the calibration process.

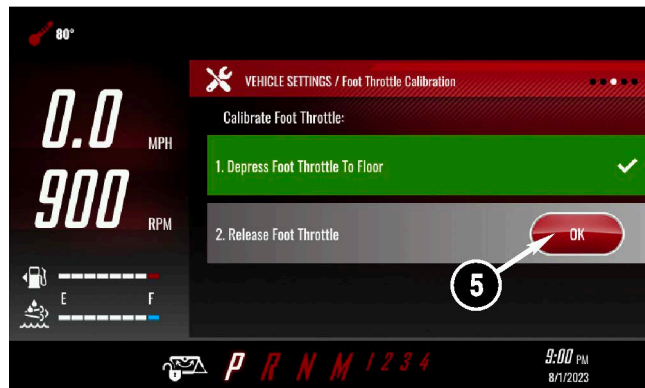

Vehicle Settings Page 4: Suspension Calibration

Touch “Begin” (1) to start the suspension calibration. The suspension will move to its lowest point. Display will show sensor output values.

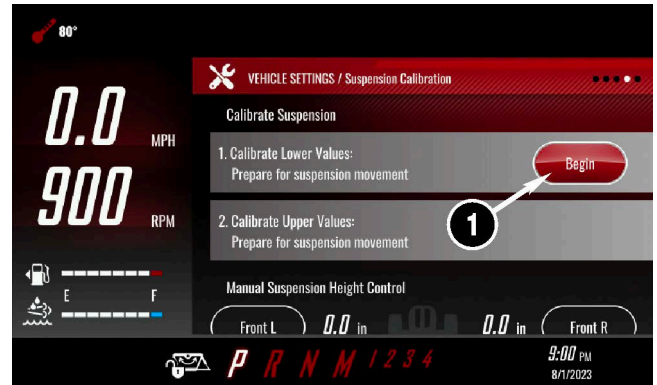

Select “Done” (2) when machine is fully lowered.

Repeat to calibrate upper values. The machine suspension will move to its highest point. Select “Done” when machine is fully raised.

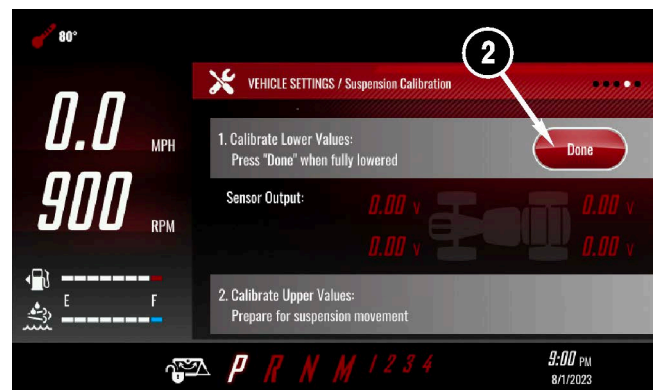

The machine can be raised or lowered manually for service. Select the portion of the suspension you would like to move (3) and select “-” or “+” (4) to raise or lower.

NOTE: After a machine power cycle, the suspension will automatically adjust to the nominal ride height.

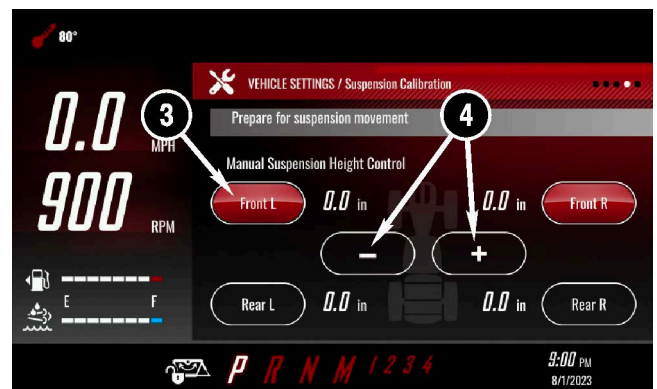

Vehicle Settings Page 5: ET AutoFold (If Equipped)

The ET Autofold feature calibration page allows the user to see the current status of all sensors as well as recalibrate the AutoFold feature. All fold sensors are listed along with their respective calibration, in range status and current voltage reading. This voltage reading is live and will change when the booms are moved.

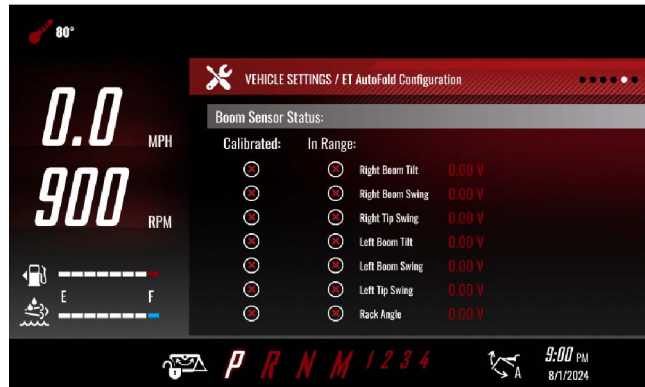

Calibrate AutoFold Feature

Swipe up to scroll to step 1, move the boom to the specified location and select “Write” (1).

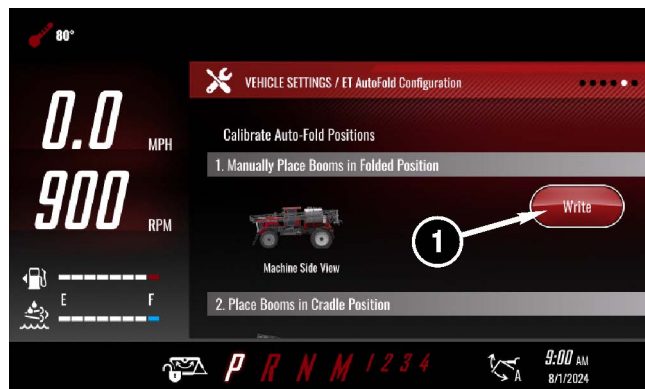

Select “Done” (2) to move to the next step.

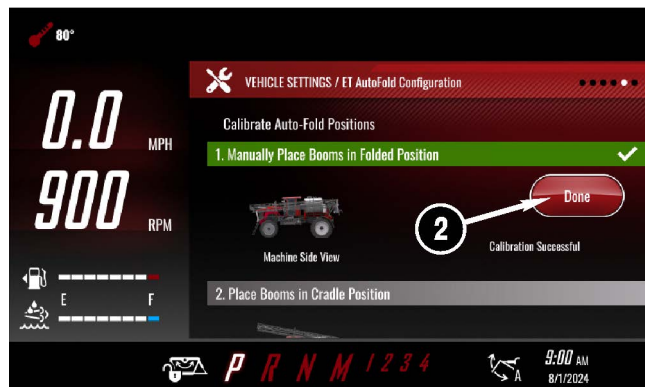

Swipe up to scroll to step 2, move the boom to the specified location and select “Write”. Continue this process until all 7 steps have been completed.

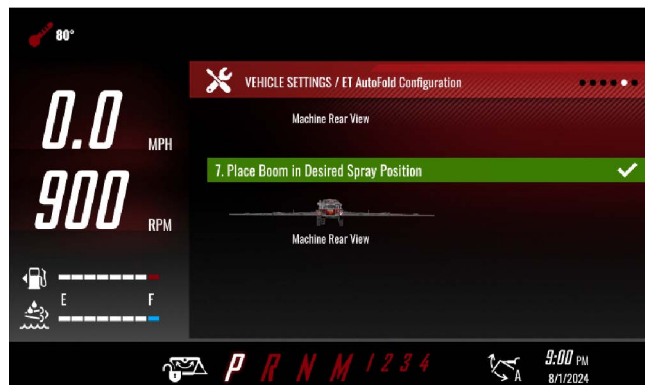

If all steps were calibrated and the sensor voltages in range, all indicator bubbles will be green (3) and the autofolding icon will show at the bottom of the screen.

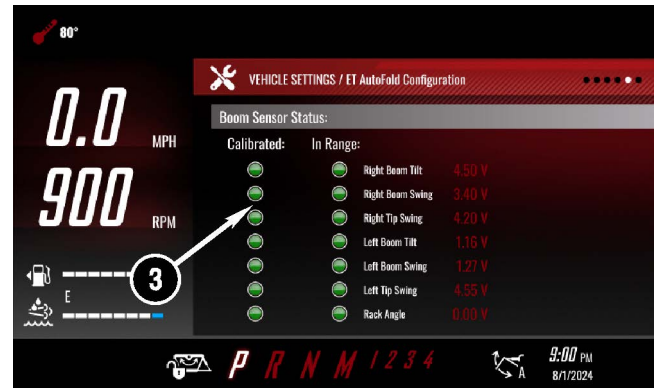

A red X in the “In Range” column (4) indicates the sensor voltage was either less than 500mV or greater than 4500mV which could indicate a:

- Faulty sensor
- Faulty electrical connection
- Faulty mechanical linkage.

Once the issue is addressed, the AutoFold feature can be recalibrated

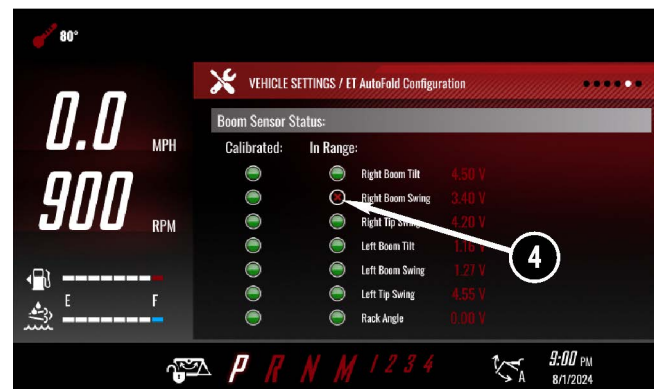

After calibration has been completed, the boom folded position as well as the boom spray position can be recalibrated at any time to adjust as needed. A sensor replacement or controller replacement will require a full recalibration of the AutoFold feature. The AutoFold feature can be completely recalibrated by starting with step 1 as stated above.

For more information on utilizing the AutoFold feature, See "AutoFold (If Equipped)" on page 4-19.

Vehicle Settings Page 6: Configuration

Swipe the screen up (1) to see all of the Vehicle Options.

Select the machine configuration (2).

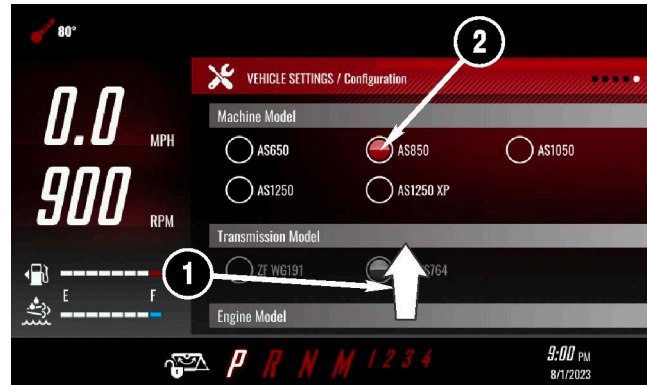

Select the Engine Model (3).

Only select options equipped on the machine (4).

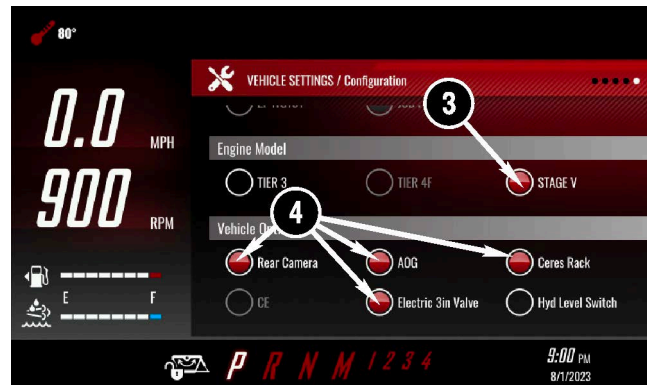

Light Buttons and Adjustable Powered Mirrors

1. Adjustable Powered Mirrors

- Twist the control stem right to engage adjustment of the right mirror. Move stem up/down and left/right to adjust.

2. Headlights

- Press the button to turn on the hood-mounted headlights.
- Press the button again to turn off the lights.

3. Marker Lights

- Press the button to turn on the marker lights and tail lights.
- Press the button again to turn off the lights.

4. Cab Front Lights

5. Cab Rear Lights

6. Boom Lights

7. Beacon Light

- Press the button to turn on the roof-mounted beacon light.
- Press the button again to turn off the light.

8. Hazard Lights

- Press the button to turn on flashing hazard lights.
- Press the button again to turn off the lights.

9. Dome Light

- Press the switch to turn the light on and off.

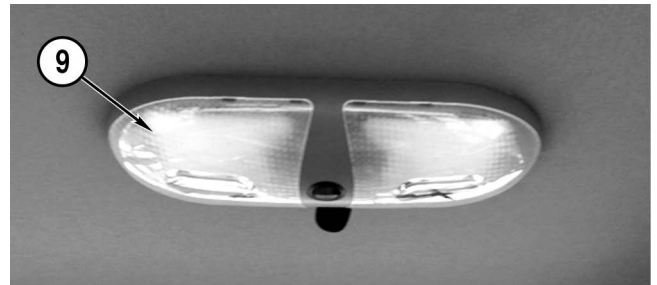
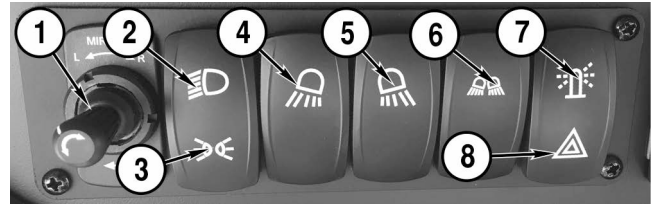

Apache Sprayer Lighting

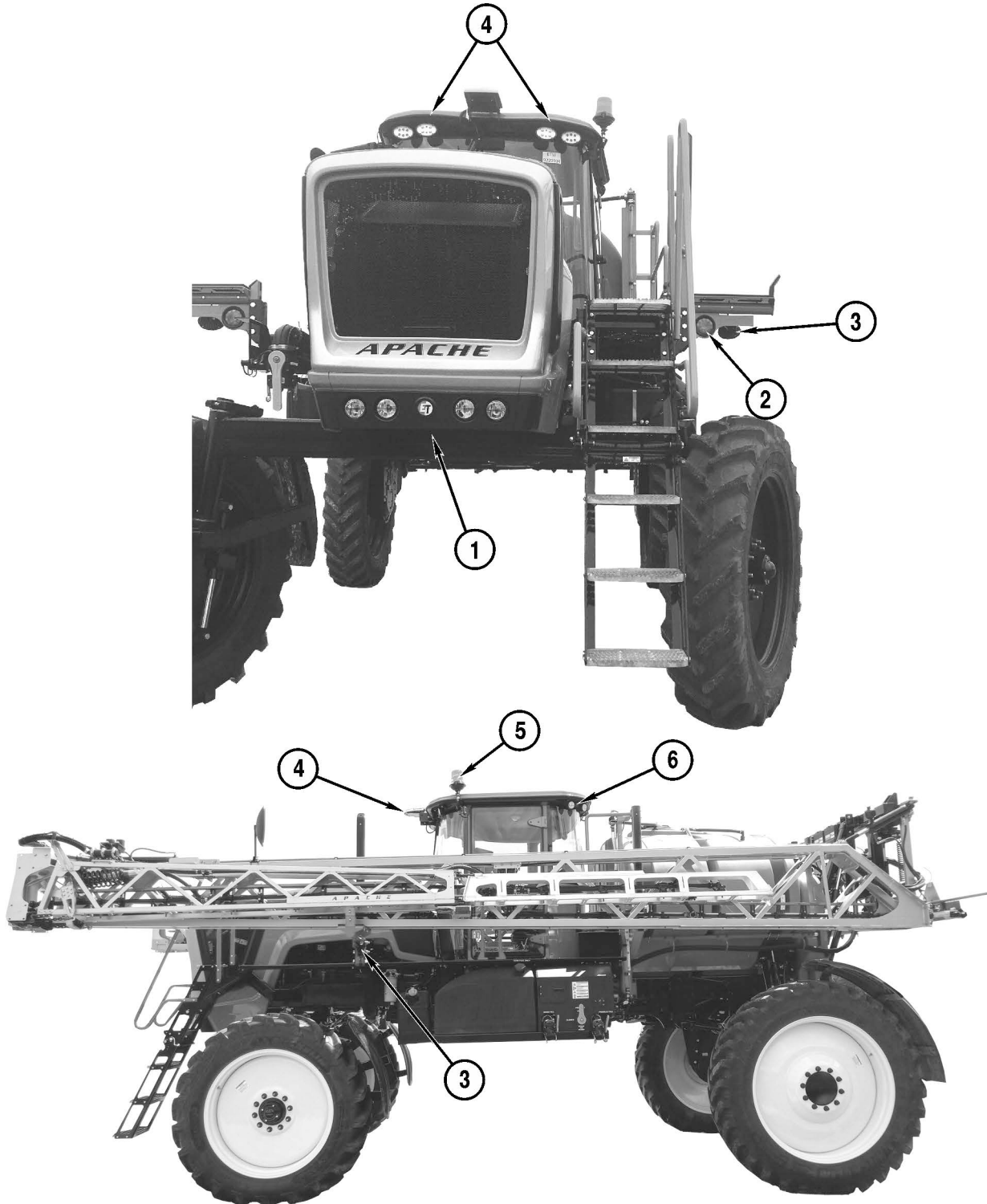

- | | |
|----------------------------------|--------------------------|
| 1. Headlights | 4. Cab Front Work Lights |
| 2. Hazard and Turn Signal Lights | 5. Beacon Light |
| 3. Dual Beam Boom Work Lights | 6. Cab Rear Work Lights |

7. Rear Hazard, Turn Signal, and Brake Lights
(Mounted at rear tire/fender)

Turn Signal and Hazard Light Function:

- When the hazard lights are turned on, light sets #5 and #7 will flash.

Turn Signal Function:

- When the left turn signal is turned on, the left side of light sets #5 and #7 will flash.
- When the right turn signal is turned on, the right side of light sets #5 and #7 will flash.

If the hazard lights are already flashing when the turn signal is activated, the lights opposite the turn indicator will glow steady while the lights on the side of the turn will flash.

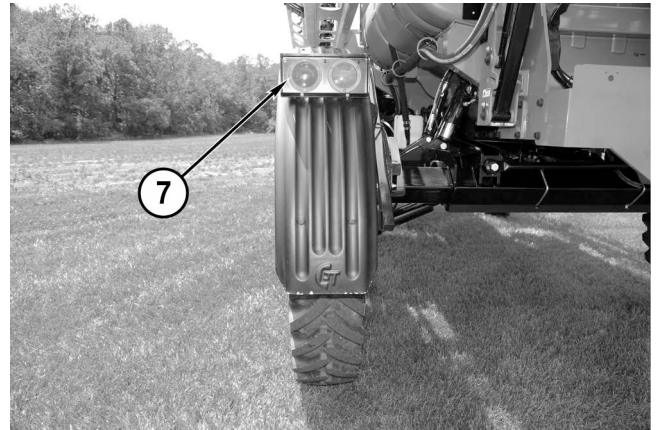

AM/FM Radio with Weather Band and Streaming Player

- AM/FM
- Bluetooth Streaming Audio
- NOAA Weatherband Tuner with Alerts

For detailed instructions visit the manufacturer’s website:
<http://asaelectronics.com/manuals-guides> -- search for model number JHD62.



Accessories

(Located behind the right-side arm rest on the back wall.)

1. Lighter.
2. Accessory power.

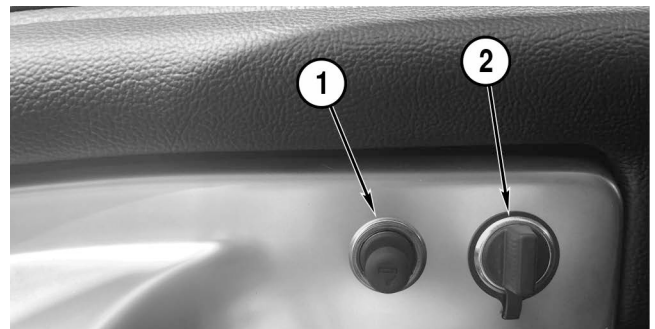

Seat Adjustment

Leather Seat

1. Slide Release Lever:

- Pull, hold and slide forward or rearward.
- Release to stop slide.

2. Fore-Aft Position of the Seat Cushion Only

- Pull up and hold to adjust, release to stop.

3. Seat Cushion Tilt:

- Pull up and hold to adjust, release to stop.

4. Ride Firmness:

- Turn the knob counterclockwise for soft ride.
- Turn the knob clockwise for firm ride.

5. Fore-Aft Isolator:

- Turn the lever to the left to allow front-to-back movement of the seat.
- Return the lever to the right to lock-out movement.

6. Backrest:

- Lift the lever.
- Position the backrest.
- Release the lever.

7. Seat Belt

8. Lumbar Support:

- Turn the knob counterclockwise for more lumbar support.
- Turn the knob clockwise for less lumbar support.

9. Height:

- Lift lever to raise the seat.
- Push the lever down to lower the seat.

10. High/Low/Off Button for Seat Cooling/Heat

- Top position is high, Center position is off, Bottom position is low.

11. Activate Seat Heat/Cool Button:

- Select fan to activate cooling. Select Seat with lines to activate heat.



Joystick and Universal Terminal Console

1. **Universal Terminal/Field Computer (option)**
2. **Joystick**
See "Apache Sprayer Direction and Speed" on page 3-30.
3. **Master Spray Button**
4. **Auto Steer Engage Button**
(If equipped)
5. **Boom Rack**
Press to move the boom rack up or down.
6. **Right Boom Tilt**
Press to tilt the right boom up or down
7. **Left Boom Tilt**
Press to tilt the left boom up or down.
8. **Transmission Upshift Trigger Button**
(back of joystick - not shown)
9. **Transmission Downshift Trigger Button**
(back of joystick - not shown)



Joystick Operation

The joystick decal is located on the right side of the back window.

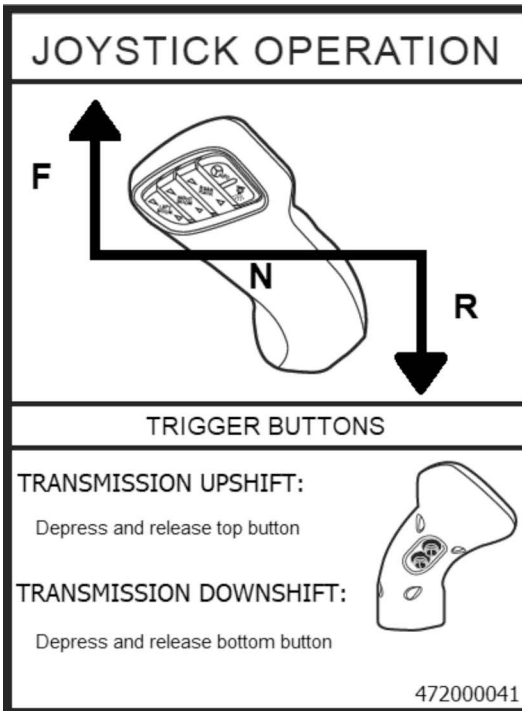

Starting and Stopping the Engine



WARNING! Impact Hazard. ALWAYS fasten your seat belt when operating the Apache Sprayer. The safety belt must be worn properly by the driver anytime the Apache Sprayer is in motion. See "Safety Belt" on page 2-4.



WARNING! Sudden Movement Hazards. ALWAYS start the engine from the operator's seat. ALWAYS set the parking brake (1) before starting the engine. ALWAYS fasten your seat belt before starting the engine.



WARNING! Fire Hazard. NEVER start the engine by shorting across the starter terminals.



Starting

1. Press the Battery Disconnect button (1) to allow power to the machine.

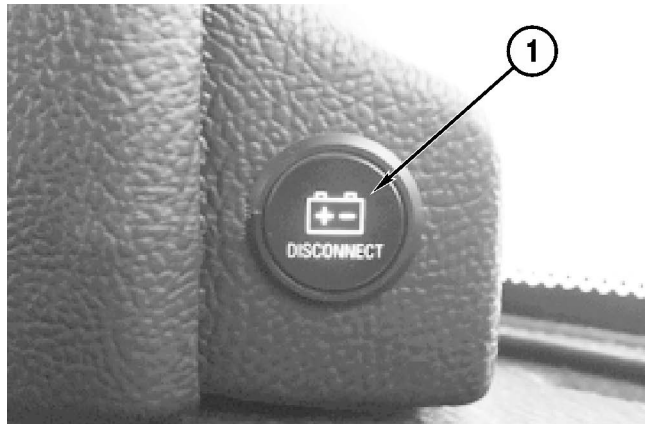

2. Press Start/Stop Button (2) to turn auxiliary power on.
3. While in auxiliary power mode, the machine will go through a series of system checks. After the checks have been completed, the machine will be ready to start.
4. Press and hold the Start/Stop Button (2) to crank the engine.
5. When the engine starts, release the Start/Stop button.



******Safety feature: Must depress the brakes to put into gear the first time.**

NOTICE: NEVER continuously crank the starter more than 30 seconds. Stop cranking and allow the starter to cool for 2 minutes between cranking to avoid damaging the starter.

NOTICE: If the engine stalls under load, immediately stop the Apache Sprayer and shift the transmission into NEUTRAL. Restart the engine immediately to avoid damaging the turbocharger.

- If the engine does not start after four attempts, see the Troubleshooting section in the engine manufacturer's service manual or contact your dealer.
- After the engine is started, check all gauges for normal engine operation. If the gauges indicate a problem, stop the engine and determine the cause.

Warm-up

Check the engine oil pressure gauge (1) as soon as the engine starts. To do this, access the App Screen and choose the Diagnostics

- If the oil pressure reading does not reach the minimum pressure of 15 psi [103.4 kPa], stop the engine and determine the cause.
- Normal engine oil pressure is 54 psi [372.3 kPa] when the engine oil is 240°F [116°C].

NOTE: Engine oil pressure can vary depending on conditions. See the engine manufacturer's service manual, supplied with the Apache Sprayer.

Check the engine coolant temperature (2), which is located on the same Diagnostics screen.

- Normal operating temperature is 185°F [85°C].
- If the engine coolant rises above 234°F [112°C], reduce the load on the engine.
- If the coolant temperature does not drop, stop the engine and determine the cause.

Stopping

NOTICE: After operating the engine under load, allow the engine to idle for 2 minutes before stopping to avoid damaging the turbocharger.

To stop the Apache Sprayer:

- Lower the engine rpm.
- Bring the Apache Sprayer to a complete stop.
- Shift the transmission to NEUTRAL by moving the joystick (1) to the center position.
- Apply the parking brake (2).
- Press the engine Start/Stop button (3) to shutoff the machine.

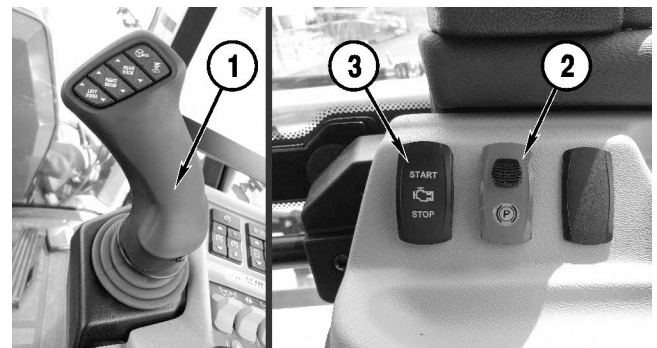
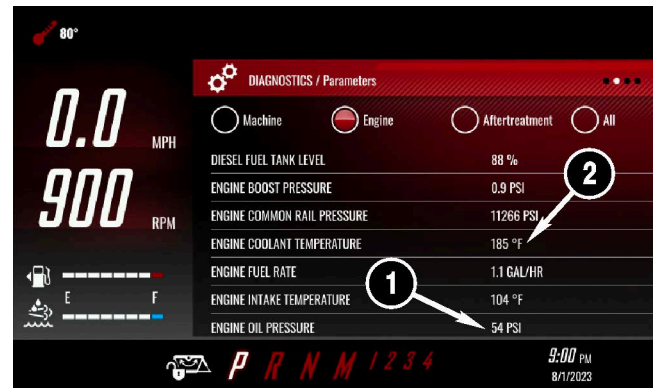

Apache Sprayer Direction and Speed



WARNING! Sudden Movement Hazards

- **NEVER** leave the operator's seat or cab when the Apache Sprayer is in gear. **ALWAYS** stop the Apache Sprayer, shift the transmission into **NEUTRAL** and then apply the parking brake before exiting the cab.
- **ALWAYS** stop the Apache Sprayer and apply the parking brake before changing direction. The Apache Sprayer must be at a complete stop before shifting the transmission into or from **FORWARD**, **REVERSE** OR **NEUTRAL**.

NOTICE: NEVER shift the transmission into **NEUTRAL** when the Apache Sprayer is moving. The transmission is only lubricated when in gear. Coasting will damage the transmission.

Neutral

At start-up, the Apache Sprayer transmission is reset to **NEUTRAL** and will be indicated at the bottom of the touch screen (1).

****Safety feature: Must depress the brakes to put into gear the first time.

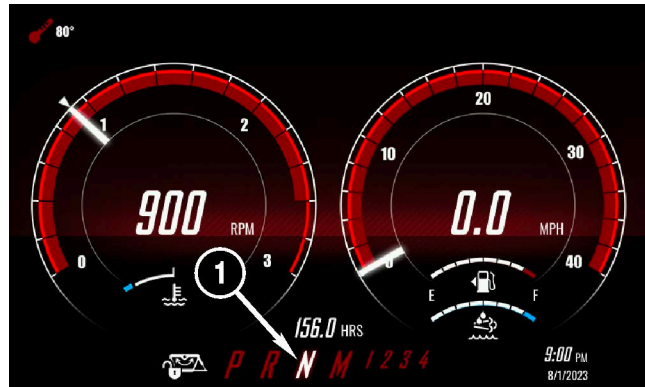

Move the joystick to the left or right to put into gear.

- Move the joystick to the left for **FORWARD** and to the right for **REVERSE**.
- Once the transmission is in gear, the gear indicator will show the current gear.

Return to **NEUTRAL** by moving the joystick to the center position.

- The transmission will immediately shift to **NEUTRAL**.

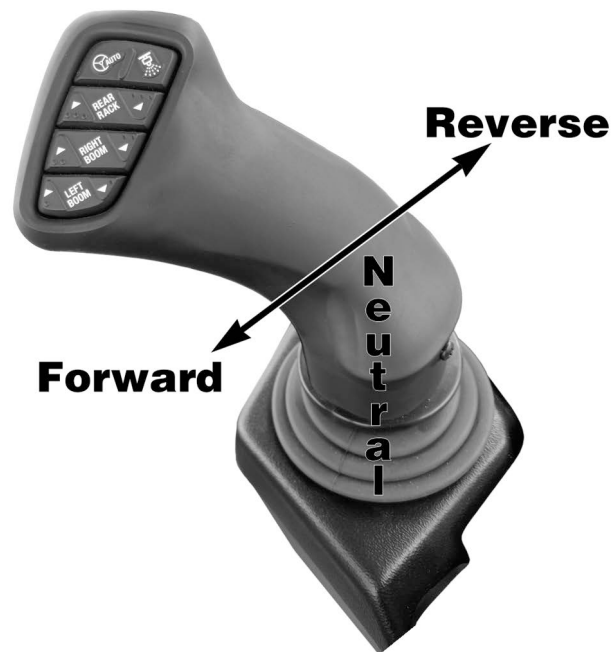

Forward

To move the Apache Sprayer forward:

Apply the foot brakes and release the parking brake.

NOTE: The transmission will not shift if the parking brake is applied.

To move forward:

- Release the park brake.
- Apply the Apache Sprayer brakes.
- Move the joystick to the left to shift into FORWARD. The machine will begin rolling forward at this time.
- Push the joystick forward to increase the engine rpm and ground speed.
- Pull the joystick back to decrease the engine rpm.

NOTE: Move the joystick to the center position to obtain NEUTRAL from a FORWARD gear.

NOTE: The Apache Sprayer will not shift into or out of NEUTRAL until the engine rpms are within an appropriate speed range.

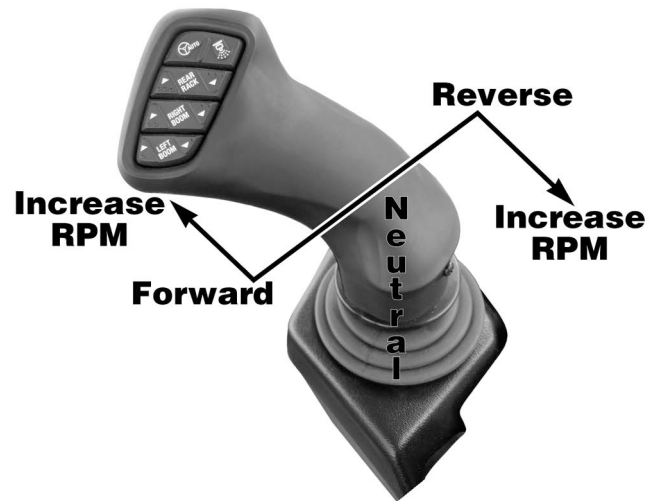

Shifting Forward Gears

The Apache Sprayer is equipped with a torque converter. This allows the Apache Sprayer to take off in any gear. Once the Apache Sprayer is moving, you may up shift or down shift without returning the transmission to the neutral position. The Apache Sprayer is equipped with four forward gears. Be aware of speed ranges for each gear. Use the Gear Speed Ranges chart for reference.

Gear Speed Ranges	
Gear	Speed
1st	0 to 5 mph [8.04 km/h]
2nd	0 to 9 mph [14.5 km/h]
3rd	0 to 16 mph [25.7 km/h]
4th	0 to 28 mph [45 km/h]

Upshifting and downshifting are achieved by pressing the trigger buttons on the backside of the joystick. Some time must be allowed for the transmission to respond.

Upshifting:

- While the Apache Sprayer is in either the FORWARD or REVERSE direction, press the top trigger button on the back of the joystick one time to shift up to the next higher gear. Repeat this motion to upshift the transmission one gear at a time.

Downshifting:

- Move the joystick slightly toward the center position to decrease engine rpm, lightly apply the Apache Sprayer brakes, then press the bottom button on the back of the joystick one time to downshift to the next lower gear. Repeat this motion to downshift the transmission one gear at a time.

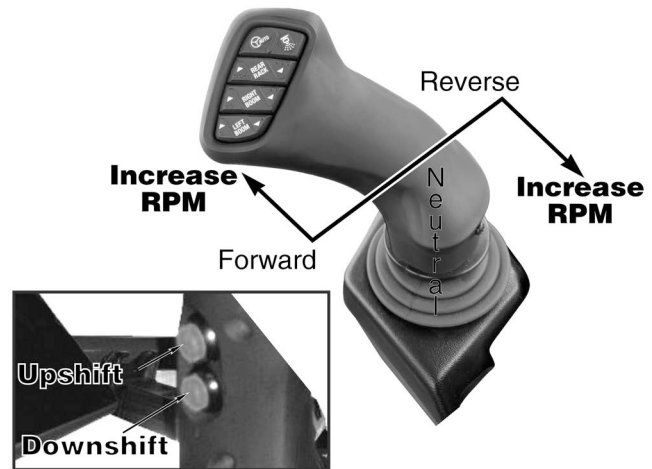

NOTE: The transmission is equipped with shift protect; the transmission will not downshift, even if the display read-out changes on the console, until the engine rpms drop down to the appropriate speed range.

NOTICE: NEVER shift the transmission into NEUTRAL while the Apache Sprayer is in motion. The transmission is only lubricated while in gear. Coasting will cause damage to the transmission.

Reverse

To move the Apache Sprayer in REVERSE:

NOTE: The transmission will not shift if the parking brake is applied.

- Apply the foot brakes.
- Release the parking brake.

To shift into REVERSE from NEUTRAL, move the joystick to the right of the center position.

- Pull the joystick back to increase the engine rpm and ground speed.
- Push the joystick forward to decrease the engine rpm.

To shift into NEUTRAL from REVERSE, move joystick up and over slowly to the center position.

NOTE: The Apache Sprayer will not shift into or out of NEUTRAL until the engine rpms are within an appropriate speed range.

Foot Throttle/Decelerator

The foot throttle/decelerator (1) can be used to override the joystick throttle. Depending on which setting is chosen for the foot pedal, it will override the joystick. Once the foot throttle/decelerator is released, the engine RPM will return to the joystick's last RPM position.

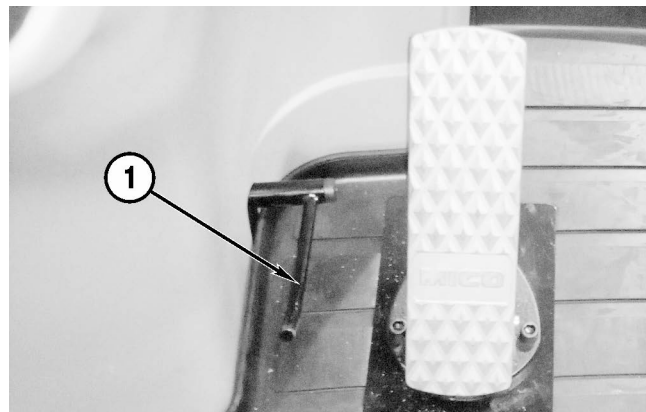

To enable the Decelerator, navigate to the first page of the Vehicle Settings screen and find the Decelerator Enable and Limit section. Click on the radial button (1) to enable this feature. Once enabled the RPM value can be adjusted with the slider (2). When the pedal is used, it will decelerate to the RPM value selected.

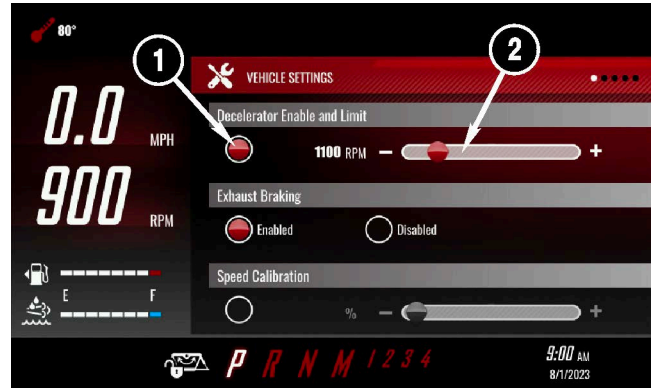

Exhaust Braking

Exhaust braking is a method which causes negative torque applied from the engine, which causes the drive-train to slow. The engine will initiate exhaust braking when the vehicle indicates that engine brake is enabled (3), throttle is at idle, and an engine overspeed is detected. All conditions must be met before it will be activated.

To enable exhaust braking, navigate to the first page of the Vehicle Settings screen and locate the Exhaust Braking section. Click the Enabled radial button (3) to activate.

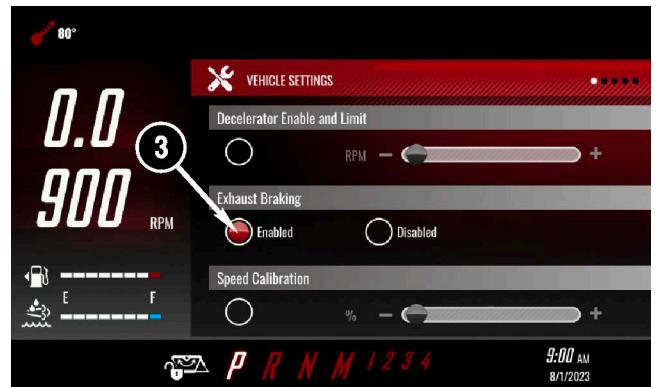

Cruise Control

The Apache offers the ability to set two cruise control points. To use the cruise control function, the machine must be in gear to operate. Press the master cruise button (1) to enable. Next, select cruise: one or two (2) on the control pad. To adjust the set speed, click the up and down arrow buttons (3). It will adjust in one mile per hour increments. Once the speed points are set, they will remain at those positions until they have been readjusted. With cruise engaged, the joystick will control the vehicle speed from 0 mph (joystick all the way back) to the selected set speed (joystick all the way forward). The cruise control will only operate up to 30 mph.

Cruise control will disengage when:

- Master cruise button has been disabled
- The selected cruise button has been pressed

Cruise control will disengage temporarily when:

- Brake has been pressed
- Transmission is put in neutral or reverse

To resume the cruise control: select the desired set point one or two on the control pad (2). Using the foot throttle can be beneficial in areas that you might want more rpm's. This will not disengage the cruise control, but will return to the chosen set speed after use.

NOTE: Once cruise control has been disengaged, speed and throttle will become manual. The rpm/throttle position will remain at the same position when cruise control was disengaged. The joystick must be pulled back to the current engine rpm to reengage normal throttle control.

When the speed point icons (1) are visible, this indicates that the cruise master has been enabled. It will also indicate the set speed points for cruise one and two.

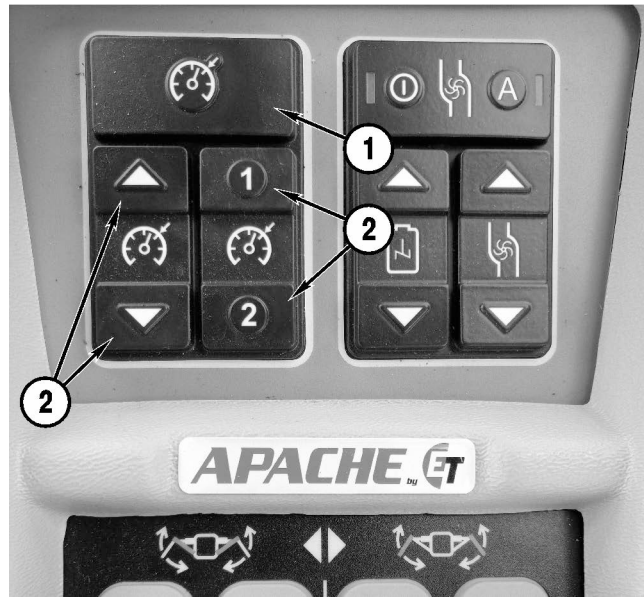

There will be red bar (2) located over the speed point icons when a set point is preselected in neutral gear. The set point speed may be adjusted up or down when preselected.

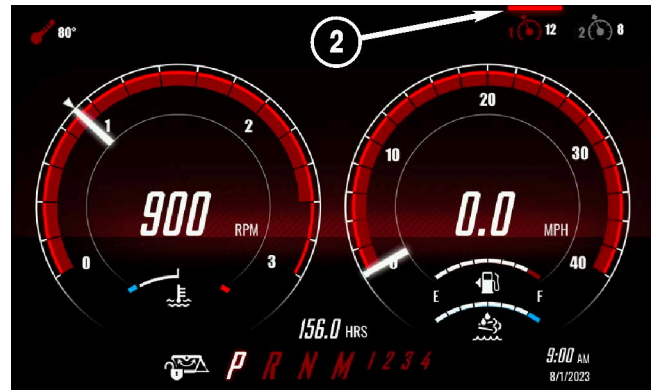

There will be a white bar (3) located over the speed point icons when the cruise control is engaged. As well as an arrow on the speedometer (3).

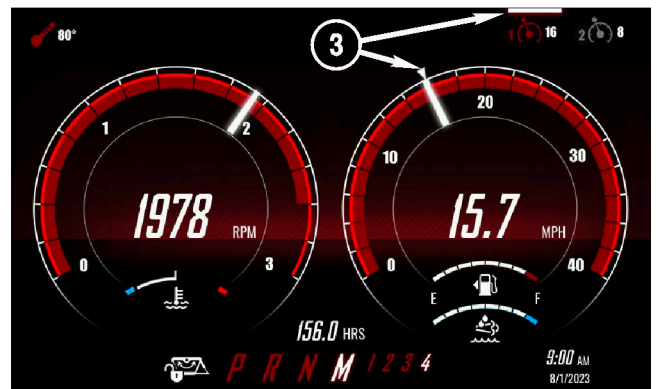

Towing

ALWAYS use towing safety equipment and proper emergency warning lighting when towing the Apache Sprayer. If the Apache Sprayer's transmission should become disabled, it may be towed for approximately 1 mile [1.6 km] at speeds less than 3 mph [4.8 km/h]. While towing the Apache Sprayer, the engine should be running at idle and the parking brake released.

If the Apache Sprayer should become disabled and the engine will not start, remove the driveshaft between the differential and transmission. The Apache Sprayer may be towed up to 1 mile [1.6 km] at speeds less than 3 mph [4.8 km/h].

NOTICE: The brakes depend on supply oil from the hydraulic system. If the engine is not running, you will have no brakes.

NOTICE: The brakes are located in the rear differential housing. If the driveshafts from the rear differential to the planetaries or drop boxes are removed, you will have no park or foot brakes. If the driveshaft between differential and park brake is removed, you will have no park brake.

NOTICE: DO NOT tow the Apache Sprayer if the:

- Driveshaft is connected and it has no hydraulic supply to release parking brake.
- Rear differential is damaged (contact dealer for repair).

NOTICE: DO NOT use the Apache Sprayer as a tow vehicle.

NOTICE: DO NOT use any part of the Apache Sprayer as a tow bar which is not designed for use as a tow bar or tow hook-up.

Hood Tilt Latch

To raise the hood, pull the latch (1) down while pulling the front of the hood down.



Battery

The batteries are located under the hood, between the engine and the cab.

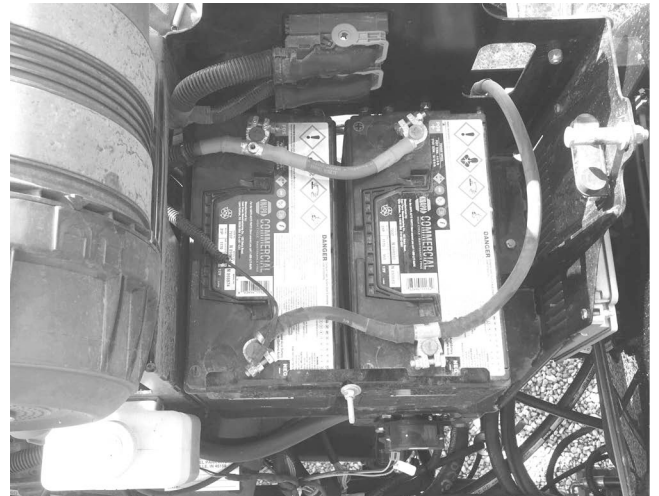

The Apache Sprayer features a battery disconnect button (1), located on the left side, near the rear of the engine compartment.

Only turn the battery disconnect button OFF when working on the machine. It will automatically shut off when the battery voltage reaches 12.4 volts.

NOTE: The negative battery cable must still be disconnected when servicing the machine.



The Cabin Power Distribution Module

Located under the armrest, the module includes a circuit board, relays, and fuses that power the cabin's operations.

For more information, see "Cabin Power Distribution Module and Relay Chart" on page 8-2.



The Chassis Power Distribution Module

Located on the right side, above the transmission, the module includes a circuit board, relays, and fuses that supply power the cab and control chassis operations.

For more information, see "Chassis Power Distribution Module and Relay Chart" on page 8-1.



Axle Adjustment (optional)

Manual

The front and rear axles on the Apache Sprayer are adjustable from 120 to 160 in. [304.8 to 406.4 cm] (measured from center of left tire to center of right tire).

Front

Safely lift the front of the Apache Sprayer so the front tires are slightly off of the ground.

Remove the two inner bolts (1) from the locking bar.

Loosen the six jam nuts (2) and six bolts (3) on the axle brace. The right front axle is shown.

NOTICE: *DO NOT extend the axle beyond 160 in. [406.4 cm] (measured from center of left tire to center of right tire).*

Manually slide the wheel to the desired width, making sure the locking bar holes are aligned.

Tighten the six bolts (3) to 80 lb-ft [108 N•m] to secure the axle in place.

Tighten the jam nuts (2).

Install the two locking bar bolts (1) and tighten.

Repeat the steps to adjust the other front axle.

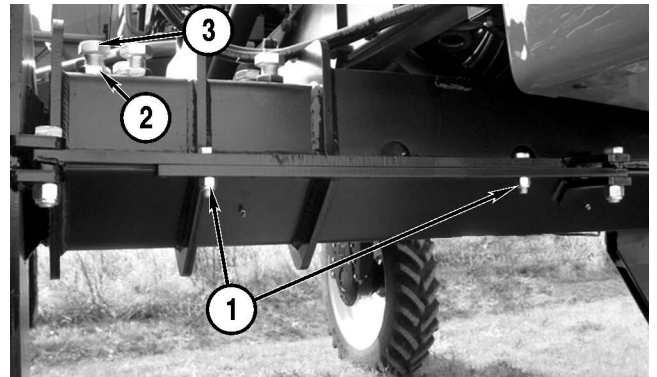

Rear

Safely lift the rear of the Apache Sprayer so the rear tires are slightly off of the ground.

Remove the two inner bolts (1) from the locking bar.

Loosen the twelve jam nuts (2) and twelve bolts (3) on the two axle braces. The left rear axle is shown.

NOTICE: *DO NOT extend the axle beyond 160 in. [406.4 cm] (measured from center of left tire to center of right tire).*

Manually slide the wheel to the desired width, making sure the locking bar holes are aligned.

Tighten the twelve bolts (3) to 80 lb-ft [108 N•m] to secure the axle in place.

Tighten the twelve jam nuts (2).

Install the three locking bar bolts (1) and tighten.

Repeat the steps to adjust the other rear axle.

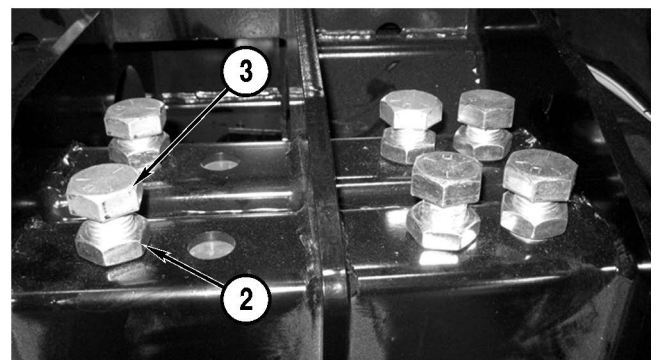
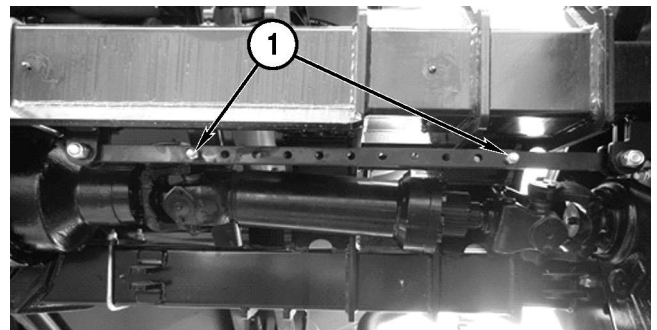

Adjust On The Go

The front and rear axles on the Apache Sprayer are adjustable from 120 to 160 in. [304.8 to 406.4 cm] (measured from center of left tire to center of right tire).

NOTE: The Adjust On The Go system will not allow the axle to be adjusted beyond 160 in. [406.4 cm].

To adjust the axles:

While the engine is idling, select the Adjust-On-The-Go icon (1) from the main screen.

For automatic mode, select front, rear, or both axles at the same time (2).

Begin driving forward at least 3 mph and press the (+) or (-) icon (3) to adjust the axles in or out.

For manual mode, access the second screen by swiping the screen to the left. Manual mode allows for individual wheel adjustment. Select one wheel, or any combination to adjust (1). Begin driving forward at least 3 mph and press the (+) or (-) icon (2) to adjust the axles in or out.

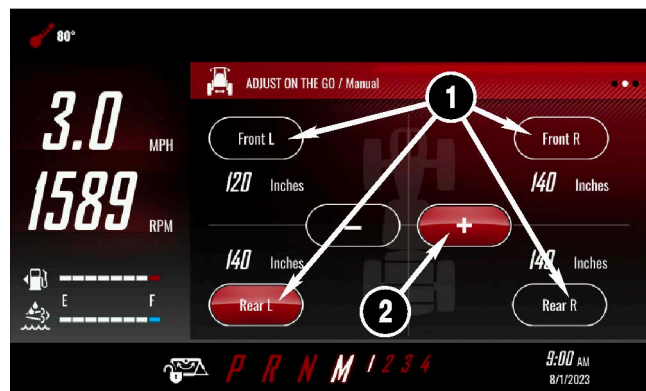
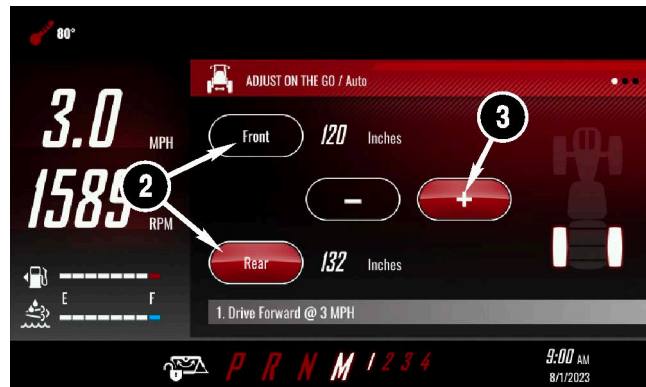
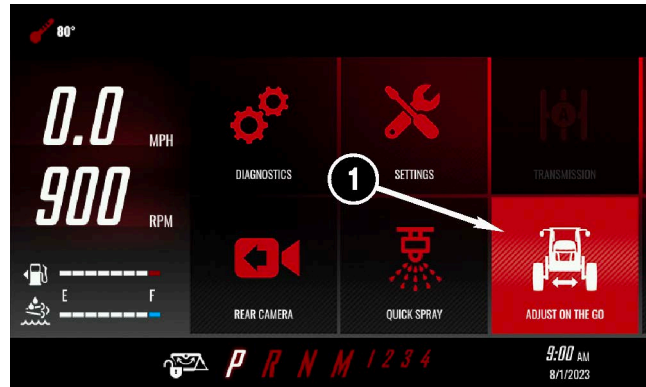

Adjust-On-The-Go Calibration

To calibrate adjust Adjust-On-The-Go, access the third screen by swiping the screen to the left. Follow the on screen instructions.

Click begin (1) to fully collapse the axles while moving at least 3 mph (2).



Once finished click done (3).

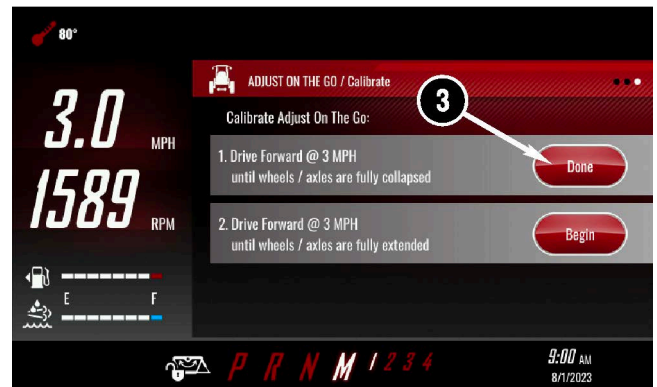

Repeat the process to fully extend the axles.

Click begin (1) while still moving at least 3 mph (2). Once finished, click done for the process to be completed.

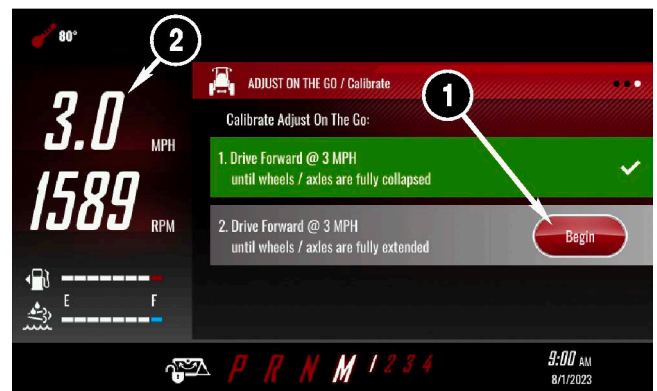

Front Axle

When activated, the Adjust-On-The-Go cylinder (1) adjusts the axle inward or outward as desired. The front wheels/axles are actuated by one cylinder per wheel. The left front Adjust-On-The-Go axle is shown.

NOTICE: The bolts (2) should be torqued to 22 lb-ft [30 N•m] at all times. Check and adjust the torque weekly. See "Adjust On The Go Axles" on page 5-24.

NOTE: Grease the axles daily when using the Adjust On The Go feature. See "Grease Axle Components (adjustable only)" on page 5-19.

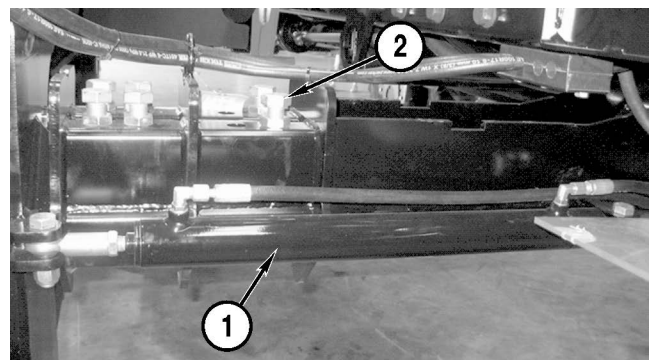

Rear Axle

When activated the Adjust-On-The-Go cylinder (1) adjusts the axle inward or outward as desired. The rear wheels/axles are actuated by two cylinders per wheel. The left rear Adjust-On-The-Go axle is shown.

NOTICE: The bolts (2) should be torqued to 22 lb-ft [30 N•m] at all times. Check and adjust the torque weekly. See "Adjust On The Go Axles" on page 5-24.

NOTE: Grease the axles daily when using the Adjust-On-The-Go feature. See "Grease Axle Components (adjustable only)" on page 5-19.

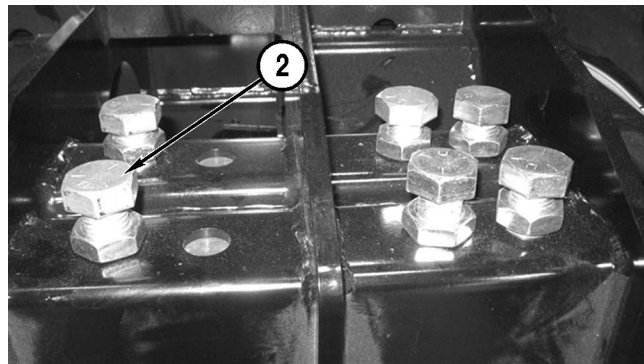
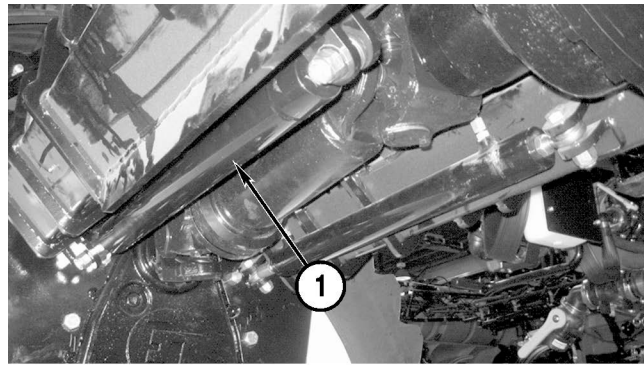

Vehicle Dynamics

To access the vehicle dynamics data, swipe to the second APP page. Touch the Vehicle Dynamics icon (1).

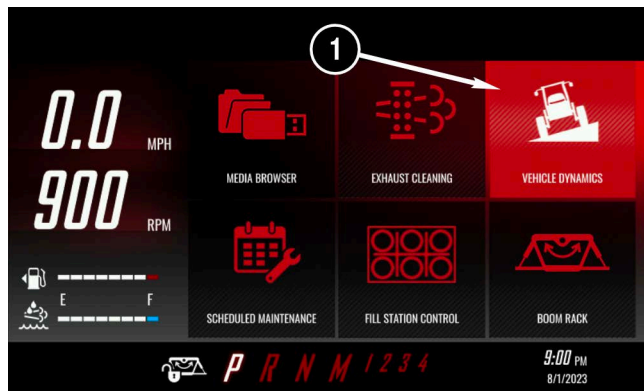

The Vehicle Dynamics screen will show the Degrees or Percentage of grade that the machine is on. To change between Degrees and Percentage, touch the screen on either value (1).

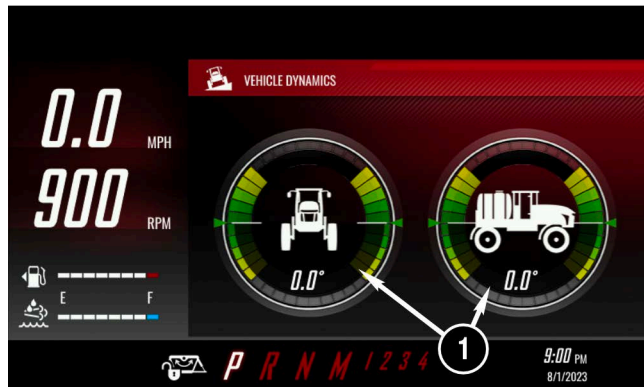

Climate Controls

1. Temperature Dial.

- Sets the desired temperature.

2. Vent Selection Buttons.

- Selects which vents are on.

3. Auto Climate Control.

- Automatically controls the fan.

4. A/C Activation Button.

- Turns A/C on.

5. Manual Fan Control.

- Controls fan speed.

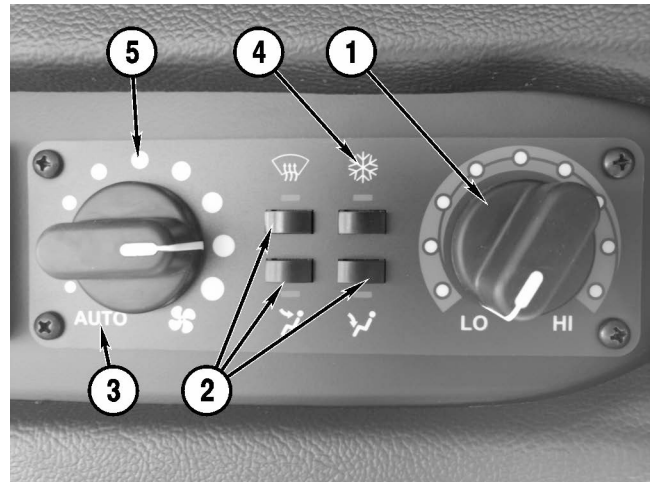

NOTE: Maximum available heating or cooling can be achieved regardless of ambient temperature, by cycling the temperature dial to “LO” or “HI”, when controlling the climate manually.

Precision Equipment

The following are factory installed precision sprayer control options.

- Raven Viper® 4+ (field computer)
- Raven RS1® Autosteer (GPS with autosteer)
- Raven AccuBoom™ (section spray control)
- CapstanAG PinPoint® III (nozzle control system)
- Raven AutoBoom® XRT (boom height control)
- Raven Boom Recirculation™ (plumbing cleaning system and waste reduction)
- John Deere® AutoTrac™ (integrated autosteer)
- Ag Leader® InCommand™ (field computer)
- Ag Leader® SteerCommand Z2™ (autosteer)
- Ag Leader® DirectCommand L2 (section spray control)
- Ag Leader® RightSpot (nozzle control system)
- Ag Leader® BoomLoop (plumbing cleaning system and waste reduction)
- Norac UC7™ (boom height control)

Refer to the respective operators manual included with the machine before use.

NOTE: Raven-based precision equipment is designed in a joint effort with Equipment Technologies and Raven and contains items that are specific to Apache Sprayers. Please note this with your service provider when seeking service.

If your Apache Sprayer is equipped with anything other than factory installed precision equipment, please contact your dealer for assistance.

Antenna Mounting Plate

On machines equipped with GPS, a steel plate is mounted at the roof-line at the front, center of the cab for magnetic base GPS antennas.



Rear Camera

If the rear camera is enabled, the full screen image will display when the sprayer is in reverse.

To manually access the camera, press the Rear Camera App icon (1).

The rear camera will display as well as the left information panel, regardless which direction the sprayer is moving. The camera will remain on the screen until a different function is chosen.

To access the Settings screen, slide the screen to the left (1).

The Rear Camera Settings screen allows the operator to turn On and Off the Automatic Reverse Camera (1). Also, the image can be reversed by turning On the Mirrored Camera button (2).

If additional cameras are installed they may be enabled in the Camera 2 and Camera 3 settings.

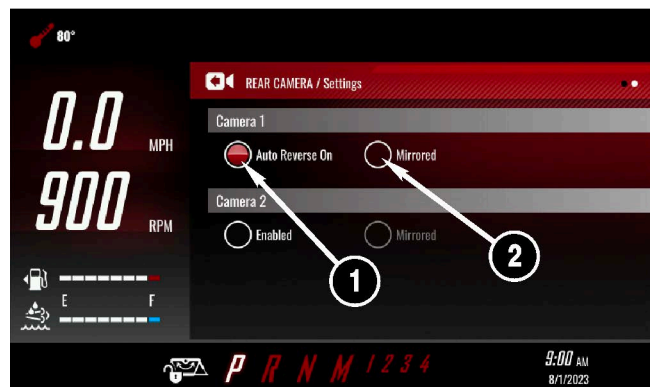
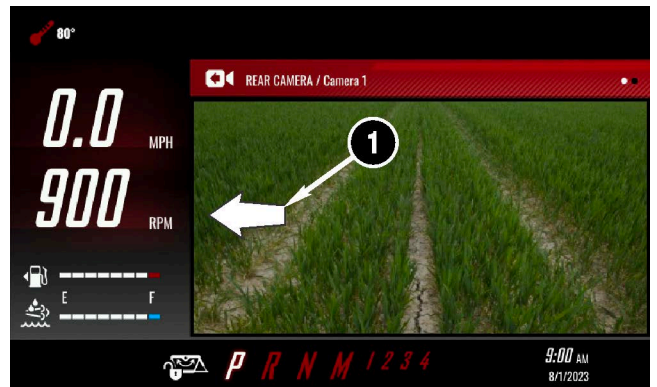
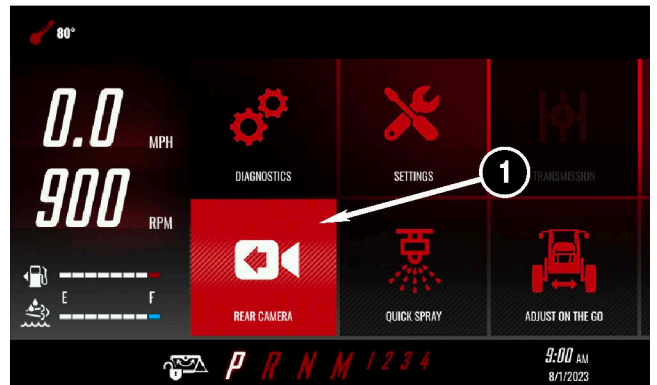

Jump-starting the Engine

Before performing any operation procedures, read the following safety messages and read the Safety Section.



WARNING! Fire Hazard. NEVER start the engine by SHORTING ACROSS the starter terminals.



WARNING! Safety Hazard. NEVER exceed 125 amps if boosting / charging a machine through the Fill Station battery terminal posts.



WARNING! Fire Hazard. NEVER exceed 125 amps if boosting / charging a machine through the Fill Station battery terminal posts.

NOTE: Boosting / charging the battery through the Fill Station battery terminals is not the recommended method of jump-starting the engine. Doing so poses safety risks to the operator and can potentially damage the machine if the electrical current exceeds 125 amps. If boosting / charging from this location take all necessary safety precautions and make certain the amperes are within the limit.

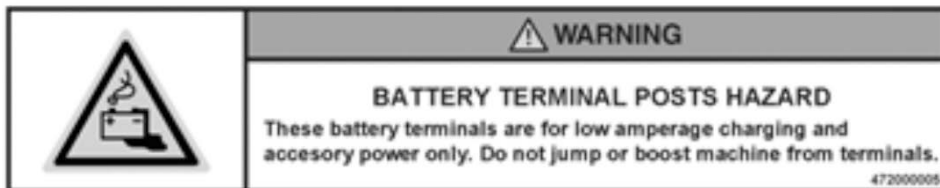

WARNING! Impact Hazard. ALWAYS fasten your seat belt when operating the Apache Sprayer. The safety belt must be worn properly by the driver anytime the Apache Sprayer is in motion.

See "Safety Belt" on page 2-4.

WARNING! Sudden Movement Hazards



- ALWAYS start the engine from the operator's seat.
- ALWAYS set the parking brake before starting the engine.
- ALWAYS fasten your seat belt before starting the engine.

ET recommends jump-starting the engine through the starter terminals, using a Booster Battery.

- The Starter is located on the engine's right-hand side and can be accessed within the front, right wheel well.
- Connect one jumper cable to the positive (+) terminal on the booster battery. Connect the other end to the starter's positive terminal (+).

- Connect the second jumper cable to the negative (-) terminal on the booster battery. Connect the other end to the starter's negative terminal (-).
- Connect the battery via the battery disconnect button.
- Set the parking brake.
- Engage the ignition.



NOTICE: NEVER continuously crank the starter more than 30 seconds. Stop cranking and allow the starter to cool for 2 minutes between cranking to avoid damaging the starter.

- If the starter motor still operates slowly, check the jumper connections to make sure they have good metal-to-metal contact.
- Once the engine is running, disconnect the negative cable from the starter, then from the booster battery. Disconnect the positive cable from the starter, then from the booster battery.
- After the engine is started, check all gauges for normal engine operation. If the gauges indicate a problem, stop the engine and determine the cause.
- If the engine fails to start after several attempts, check connections and retry or contact your dealer.

Exhaust Cleaning



Warning! During exhaust system cleaning operations, the engine may run at elevated idle and hot temperatures for an extended period of time. Exhaust gases and exhaust system components reach temperatures hot enough to burn people, or ignite or melt common materials. Keep machine away from people, animals, or structures which may be susceptible to harm or damage from hot exhaust gases or components. Avoid potential fire or explosion hazards from flammable materials and vapors near the exhaust. Keep exhaust outlet away from people and anything that can melt, burn, or explode.

Closely monitor machine and surrounding area for smoldering debris during and after exhaust filter cleaning.

Automatic Cleaning

To access the Exhaust Cleaning app, slide the main screen to the left until the Exhaust Cleaning app is visible. Touch the app icon (1) to continue to the next screen.

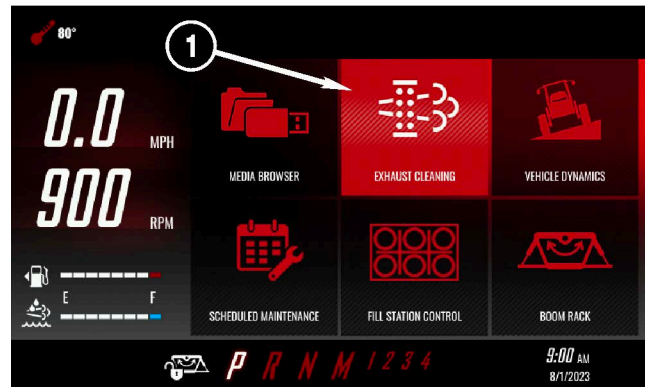

The button (2) will be filled in when in Automatic Mode. This will allow the machine to perform the exhaust cleaning when needed.



This is the recommended procedure for exhaust cleaning.

When the exhaust cleaning is in progress, the cleaning lamp (3) will be flashing. Also, the high exhaust temperature lamp (4) will be on.



Both lamps will be indicated at the top of the screen as well as under the Lamp Description section of the Exhaust Cleaning app.

Disabled Mode

To access Disabled Mode, slide the main screen to the left until the Exhaust Cleaning app (1) is visible.

Touch the Exhaust Cleaning icon to continue to the next screen.

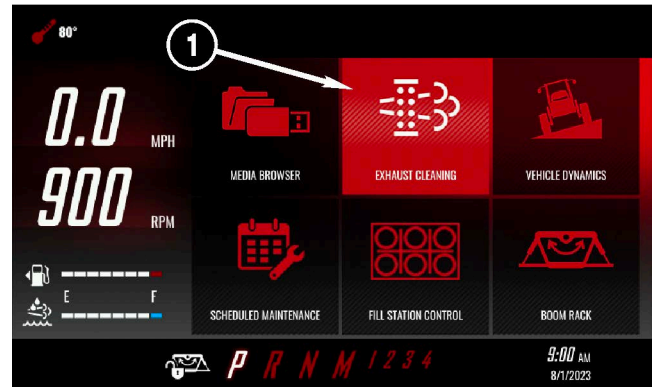

To change from Automatic mode to Disabled mode, touch the Disabled radial button (2). In this mode, the exhaust cleaning will not take place until it has been switched back to Automatic or activated manually. See "Manual Cleaning" on page 3-50.

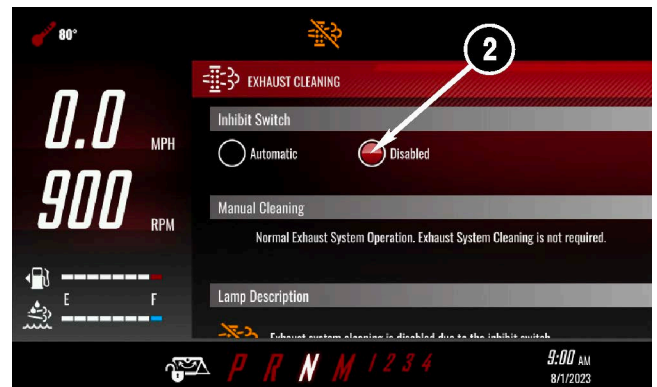

The Cleaning Inhibit Switch lamp (3) will be indicated at the top of the screen as well as under the Lamp Description section of the Exhaust Cleaning app.

It is recommended to switch to Disabled Mode if the machine will be running in confined locations such as a shop for maintenance.

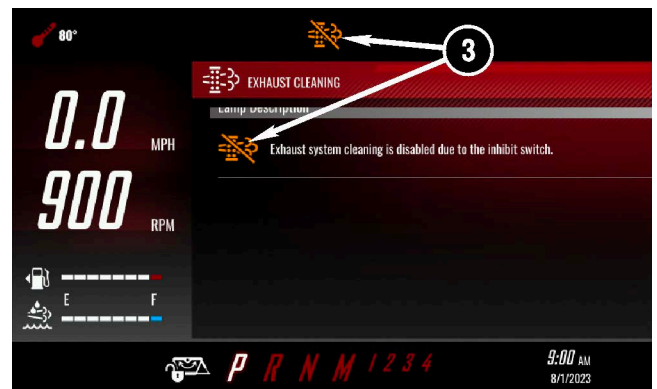

Manual Cleaning

When the machine Exhaust Cleaning is disabled, the machine will determine when it is time to perform a cleaning. It will be indicated at the top of the screen with the Cleaning Required lamp (1). The manual cleaning option will then be available. Once the two criteria are met, Apply Park Brake and Idle Engine (2), the Begin button will be active to start the process.

Press the Begin button (3) to start the Exhaust Cleaning procedure. After the Begin button (3) has been pressed, the Inhibit Switch will be changed to Automatic (4). This will revert back to Disabled once the cleaning is complete.

After the Begin button has been pressed, there will be a circle icon (5) that indicates that the process has begun. It will take a few seconds as the systems begin to communicate before the mechanical items begin to run through the steps of cleaning.

As the process moves to the next steps, the lamps will appear at the top of the screen as well as in the Exhaust Cleaning app screen. The Cleaning lamp will begin to flash along with the solid High Exhaust Temperature lamp (6). The RPM's will also increase to 1000 (7) to assist in elevating the exhaust temperature.

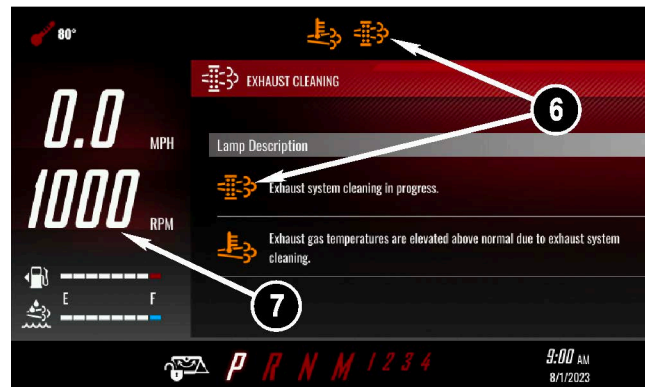
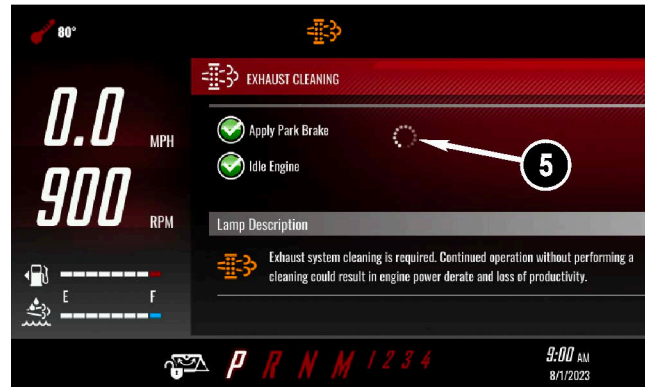
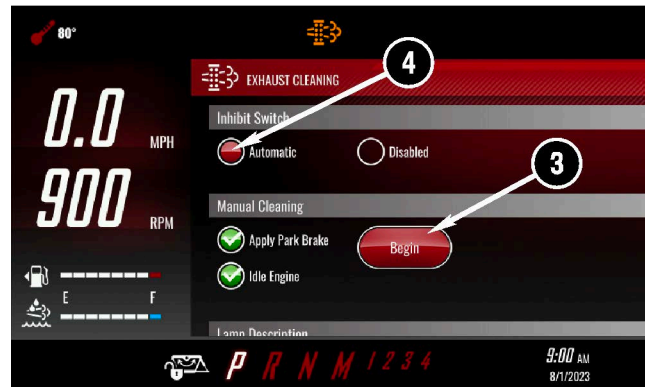
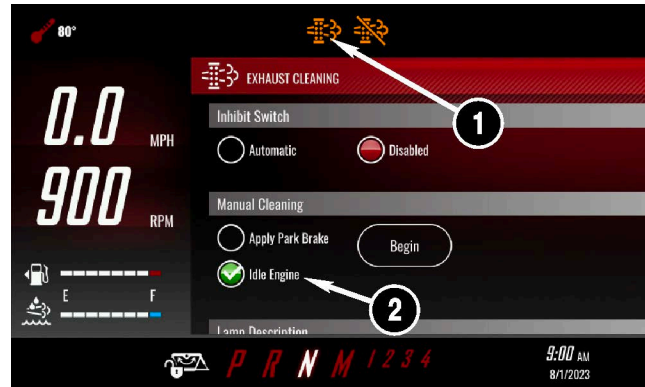

If the Park Brake is released or the Engine Idle is manually changed, the Exhaust Cleaning process will be aborted (8). Once the process has been aborted, the Inhibit Switch will revert back to Disabled. The process can be started again, once the criteria has been met.

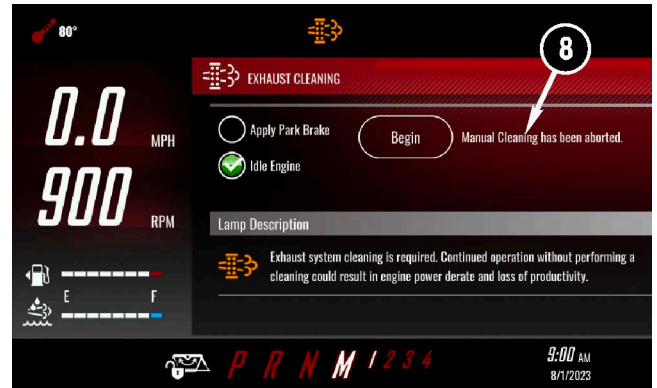

Low DEF Fluid

10% DEF fluid level:

A vehicle warning will pop up on the screen with the engine fault code and a brief explanation of the fault. Click on the OK button (1) to return to the main screen.

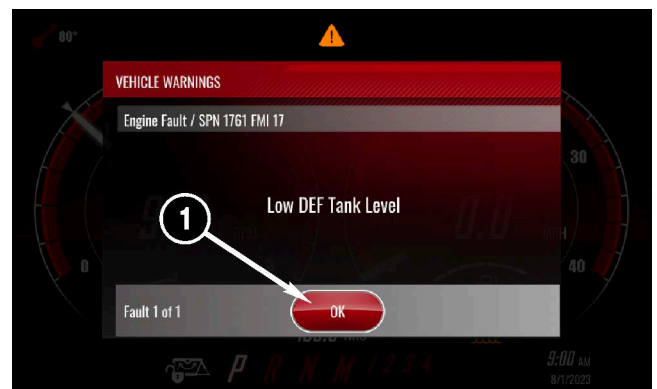

The Yellow warning lamp (2) and the Amber DEF lamp (3) will be on. Both lamps will remain in this state until DEF fluid is added. To view a full description of the warning, press the Yellow warning lamp (2).



The Diagnostics/Faults page will give a full description of the warning (4).

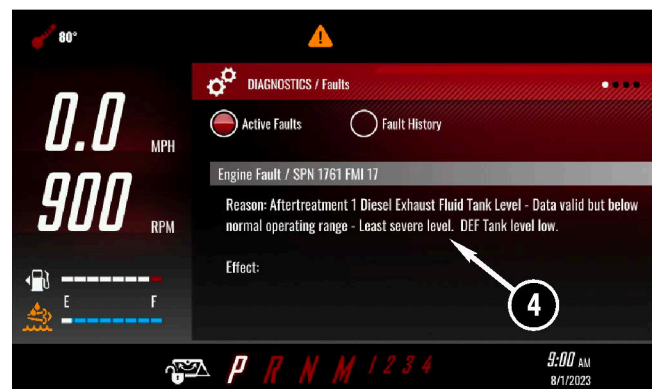

5% DEF fluid level:

A vehicle warning will pop up on the screen with the engine fault code and a brief explanation of the fault.

Click on the OK button (1) to return to the main screen.

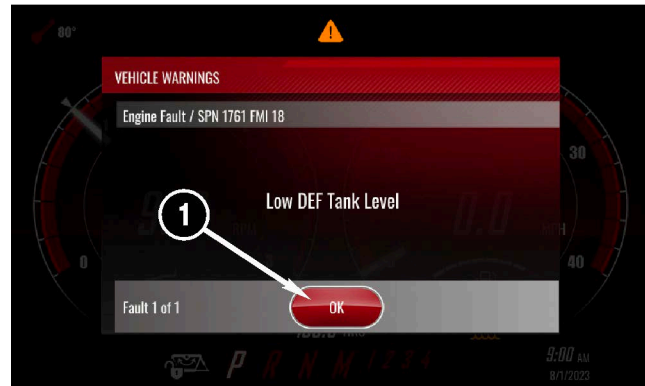

The Yellow warning lamp (2) and the flashing Amber DEF lamp (3) will be on. Both lamps will remain in this state until DEF fluid is added.

To view a full description of the warning, press the Yellow warning lamp (2).

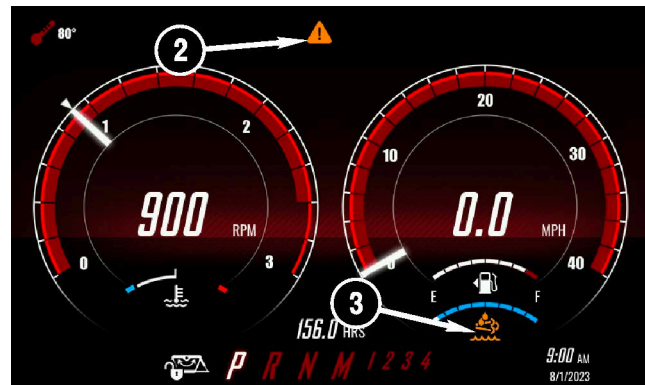

The Diagnostics/ Faults page will give a full description of the warning (4).

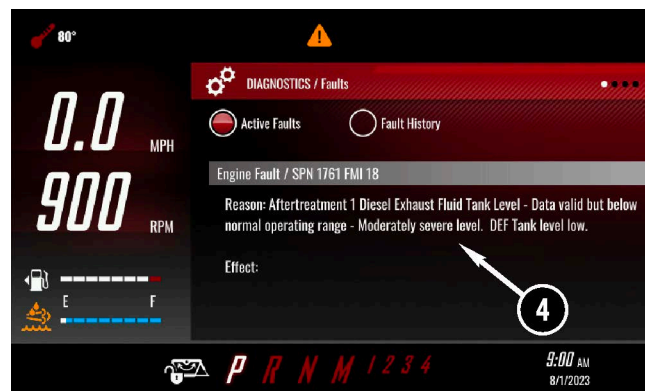

2.5% DEF fluid level:

A vehicle warning will pop up on the screen with the engine fault code and a brief explanation of the fault. Click on the OK button (1) to return to the main screen.

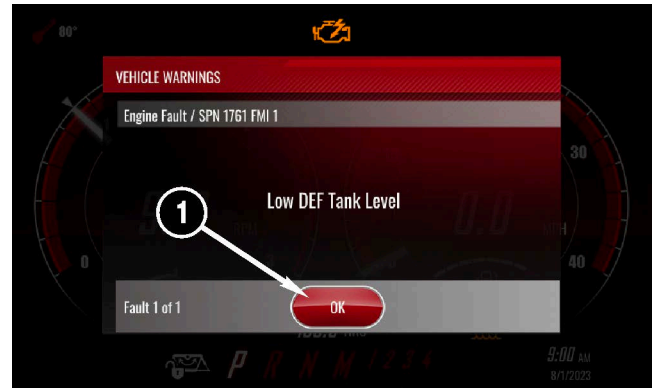

The Amber Engine Warning lamp (2) and the Flashing Amber DEF lamp (3) will be on. Both lamps will remain in this state until DEF fluid is added. **The first inducement derate will become active.**

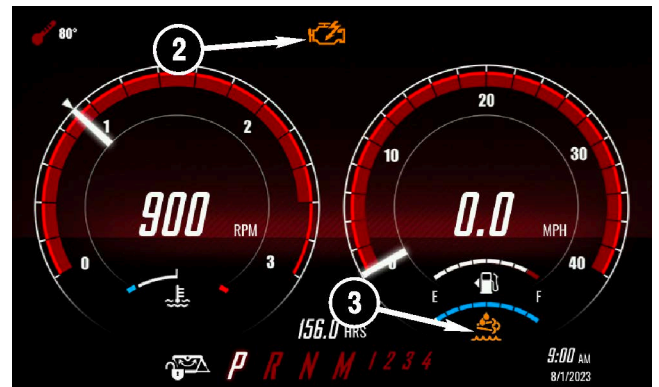

To view a full description of the warning, press the Amber Engine Warning lamp (2).

The Diagnostics/ Faults page will give a full description of the warning (4).

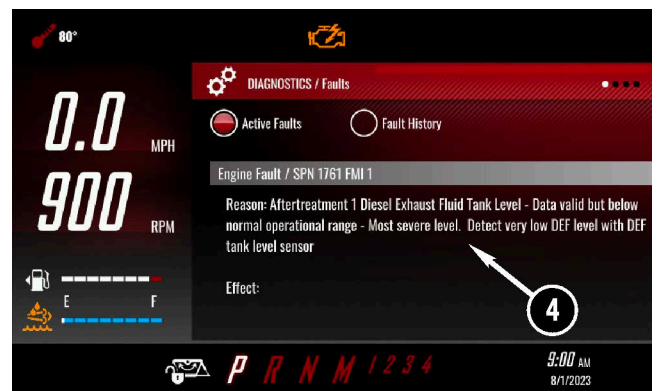

0% DEF fluid level:

Soon after the fluid is depleted, the Amber Engine lamp (1) will change to Red Stop Engine Warning.

The final inducement derate will be applied (Engine torque derate, Low Idle lock).

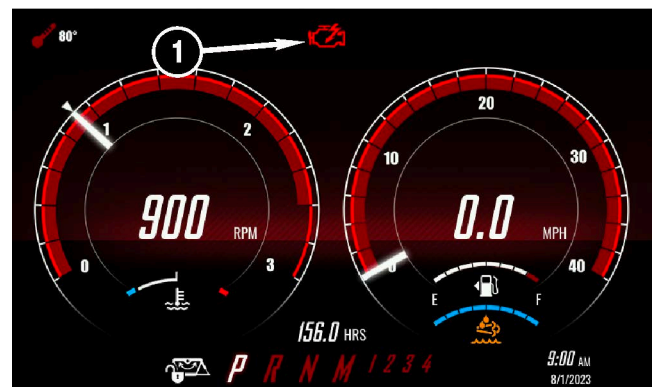

Boom Rack

This machine may be equipped with a rack locking feature as well as a rack auto leveling system.

Note: The rack should only be locked to fold, unfold, or transport the machine. The rack should not be locked while spraying. By default, the machine disengages the rack lock when the machine is traveling at or above 8 mph (13 km/h) to protect the boom system from damage.

To access boom rack features, slide the main display screen to the left until the 'BOOM RACK' app icon (1) is visible. Touch the icon to enter the app.

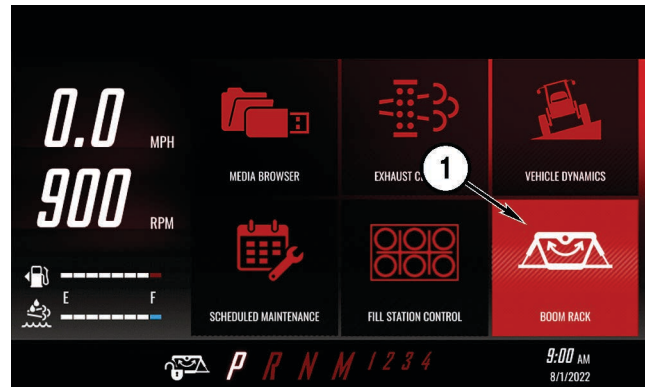

The main screen of the 'Boom Rack' app appears.

1. The lock status is displayed over the top of the rack image.
2. The angle of the rack relative to the chassis is displayed above the rack image.
3. The 'Rack Lock' button is located at top right.
4. The 'Auto Level' button is located at top left.
5. The 'Rack Shift L' button is located to the left of the rack image.
6. The 'Rack Shift R' button is located to the right of the rack image.

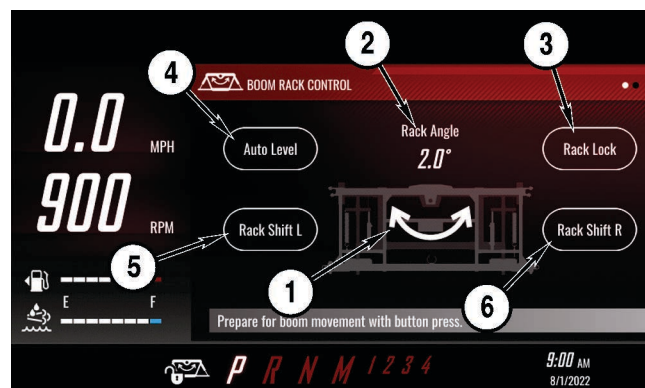

Rack Lock

To lock the rack, touch the 'Rack Lock' button (1) in the top right of the 'Boom Rack' app main screen.

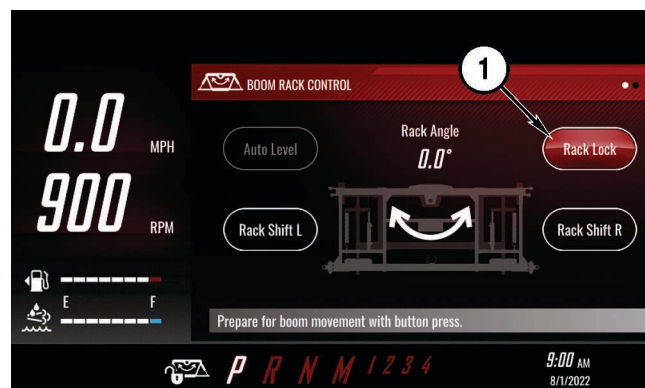

When the rack is locked, an orange padlock (1) appears over the picture of the rack in the app screen as well as on the bottom row rack icon (2).



To unlock the rack, touch the 'Rack Unlock' button (1) in the top right of the 'Boom Rack' app main screen.

Note: When the sprayer reaches 8 mph (13 km/h), the rack will automatically unlock. Both the rack lock button on the app screen and the bottom row rack icon will be grayed out.

Note: If the autoboom feature is equipped, the rack will automatically unlock when the autoboom feature is engaged.

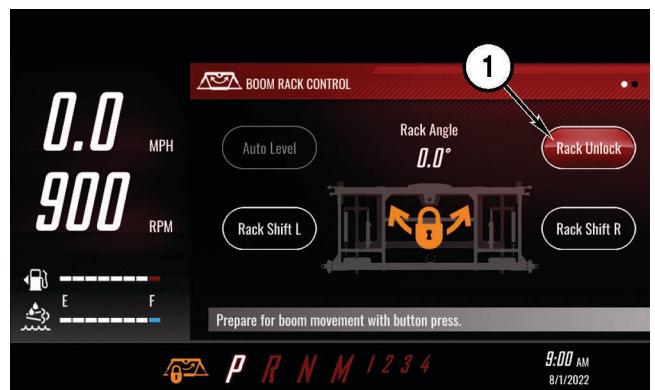

The rack can also be locked or unlocked from the main screen.

The rack lock icon (1) is located at the bottom left of the screen, to the left of the Park (P) icon. Touch the icon to lock or unlock the rack.

The icon is white and the padlock is open when the rack is unlocked.

The icon is orange and the padlock is closed when the rack is locked.

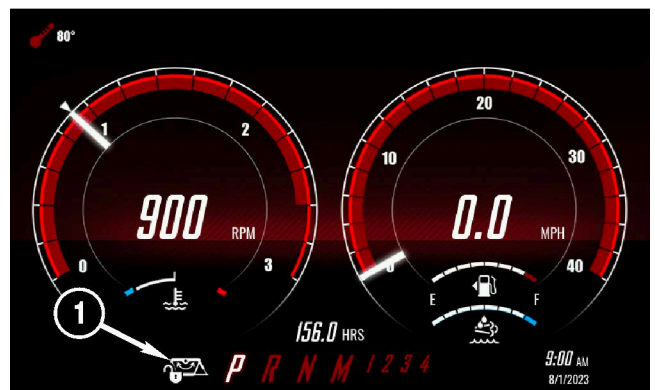

The rack can also be locked by pressing the padlock button on the keypad console (1). When the rack is locked a light will illuminate next to the padlock.

Press the padlock button (1) again to unlock the rack

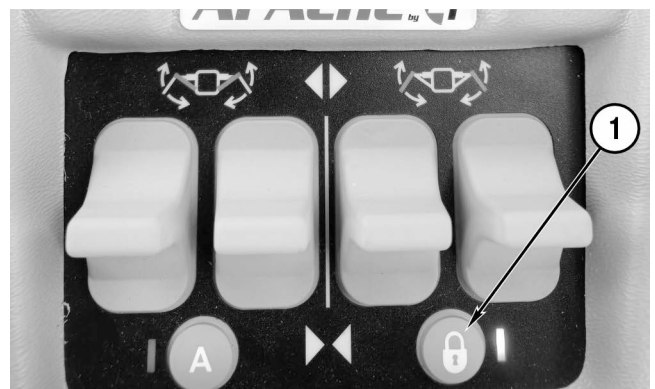

Rack Leveling (Manual)

The 'Rack Shift L' and 'Rack Shift R' buttons can be used to shift the rack in one direction or the other to obtain a level position before folding or unfolding.

If the left side of the rack needs to be raised, first lock the rack, then touch and hold the 'Rack Shift L' button (1) until the rack is level.

If the right side of the rack needs to be raised, first lock the rack, then touch and hold the 'Rack Shift R' button (2) until rack is level.

The rack can then be folded.

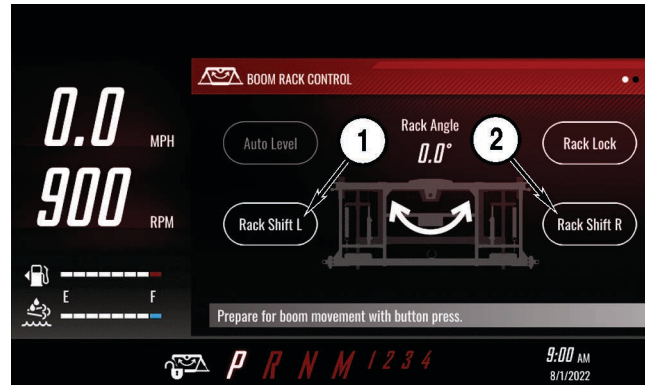

Rack Leveling (Auto Level)

Note: Before using the 'Auto Level' feature, ensure the booms are in an unobstructed area.

The 'Auto Level' feature is available for models equipped with an angle sensor at the center pivot of the rack.

If the rack is not level, the 'Auto Level' button (1) is enabled. Touch and hold the 'Auto Level' button until the rack and wings are in a level position.

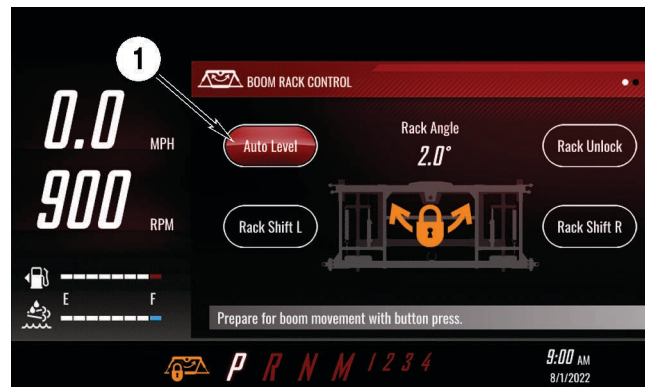

Rack Manifold Cleanout

The rack manifold and suspension cylinders are flushed from the factory, but air can enter the system over time.

If air is in the system, the manifold can be cleaned using the 'Boom Rack' app. Air in the system can be identified by a rack that continues to move when the rack lock is engaged.

Confirm the area is clear and the boom wings have adequate movement clearance.

Unlock the rack if it is locked.

Touch and hold the 'Rack Shift L' button (1) for at least 5 seconds. The rack may move some.

Release the 'Rack Shift L' button and touch and hold the 'Rack Shift R' button (2) for at least 5 seconds. The rack may move some. Release the 'Rack Shift R' button.

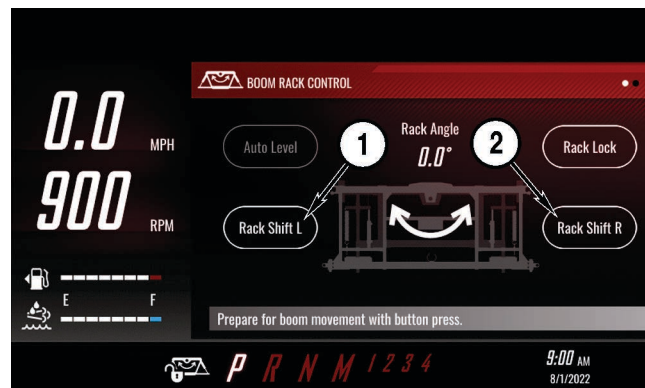

Rack Angle Calibration

To calibrate the rack angle sensor and to select machine equipment, slide the screen to the left to view page 2 of the 'Boom Rack' app.

If the machine is equipped with Raven autoboom XRT system, select the 'XRT CAN' option (1) under 'Rack Angle Sensor Type'.

If the machine is not equipped with autoboom, select the 'Analog' option (2).

If the machine is equipped with Raven autoboom XRT as well as the Raven Damping System, select the 'XRT Damper' option (3) under 'Rack Control Type'.

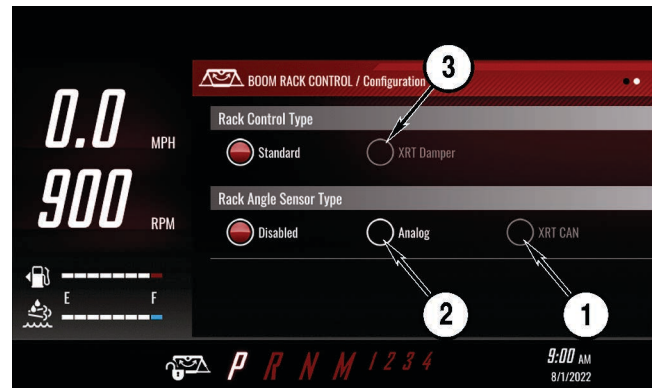

If 'Analog' sensor type (1) is selected, a calibration mode appears below the sensor type selection. The calibration must be performed before using boom rack features.

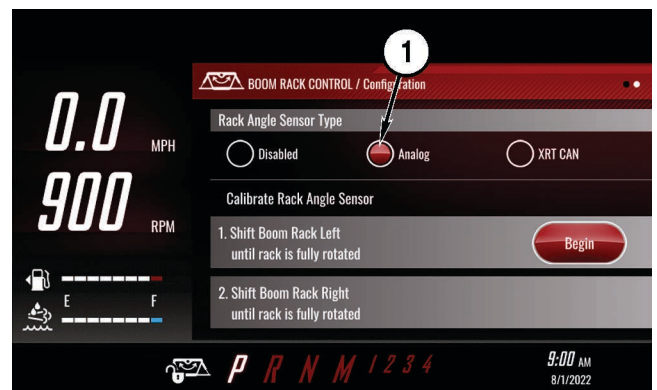

Following the calibration instructions, booms must be unfolded, parking brake applied, and booms must be in an unobstructed area.

Touch and hold the 'Rack Shift L' button (1) to obtain the first sensor output voltage. This will move the rack and wings to one extreme.

Touch the 'Done' button (2) when the rack and wings have stopped moving.

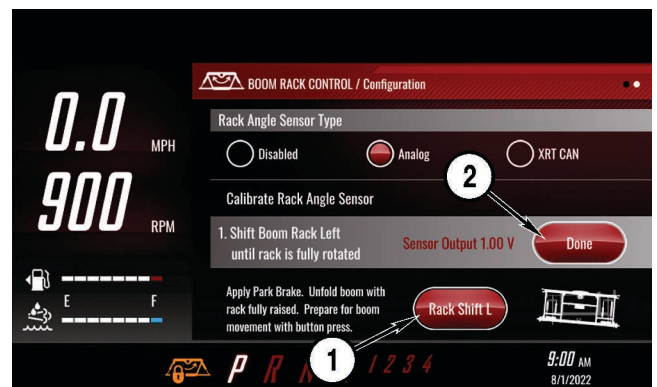

Touch the 'Begin' button (1) to start the second portion of the calibration.

Touch and hold the 'Rack Shift R' button to obtain the second sensor output voltage. This will move the rack and wings to the other extreme.

Touch the 'Done' button when the rack and wings have stopped moving.

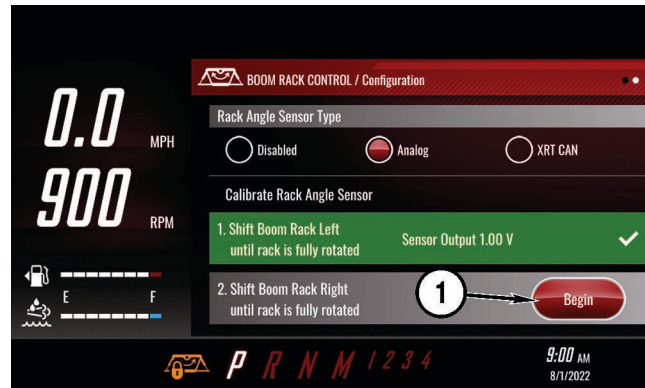

Both calibration steps are highlighted green and sensor output voltages are displayed after calibration is complete.

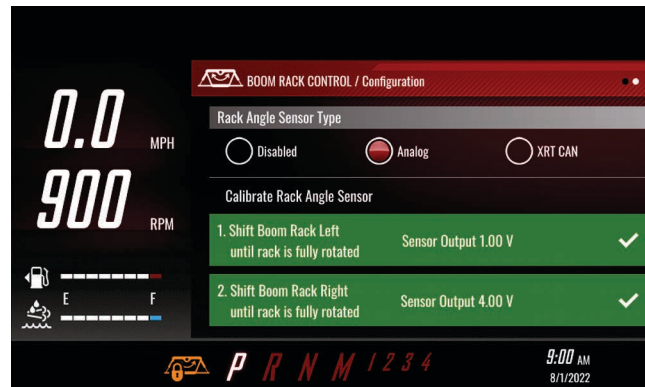

If the XRT sensor type (1) is selected, the sensor will be calibrated through the Raven autoboom XRT calibration procedure. If the calibration does not give an accurate zero reading when the rack is level with the machine, the 'Rack Angle Zero Offset' (2) can be adjusted.



To adjust the offset, select the Rack Angle Zero Offset (1). The button below the offset menu will be red.

Use the slider bar or the plus/minus icons to adjust the offset until the Current Angle (2) reading displays zero.

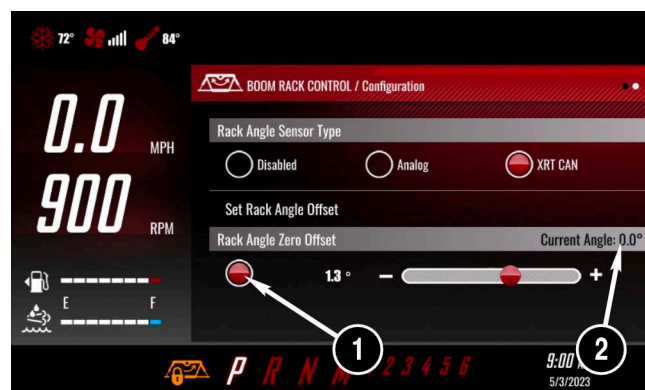

APACHE™

CHAPTER 4

WET SYSTEM OPERATION

NOTICE: Before performing any wet system operation procedures, read the Safety Section on page 2-1.

Wet System Overview

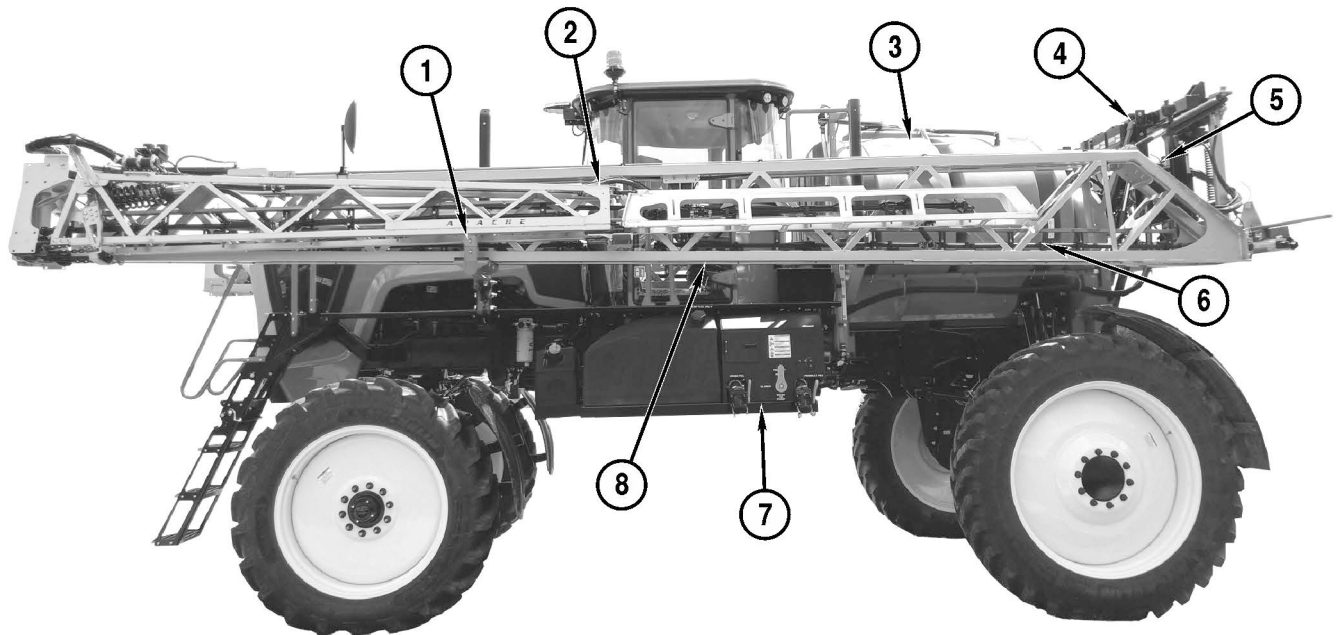

- | | |
|------------------|-------------------|
| 1. Boom Cradle | 5. Flow Controls |
| 2. Left Boom Tip | 6. Rinse Tank |
| 3. Product Tank | 7. Fill Station |
| 4. Boom Rack | 8. Left Boom Wing |

Fill Station - 2 IN Valve

The 2 inch fill station features an electric agitate/Rotoflush valve with a manual rinse/spray valve.

1. **Hand Rinse Valve**
This valve releases water from the dedicated hand rinse tank.
2. **Rinse Tank Fill**
3. **Product Valve**
This valve directs flow from the product tank to the pump or from the rinse tank to the pump.
4. **Product Tank Fill**
5. **Key Pad Electric Valve**
LED lighted push button controls for product pump, Rotoflush, and agitate. See “Electric Valve Operation” on page 4-3 for operation.
6. **Battery Terminals**
Can be used for external pump fill.
7. **Agitation/Rotoflush Valve**
During normal spraying operation, this valve is electronically actuated and controlled by the buttons on the fill station keypad or in the cab.

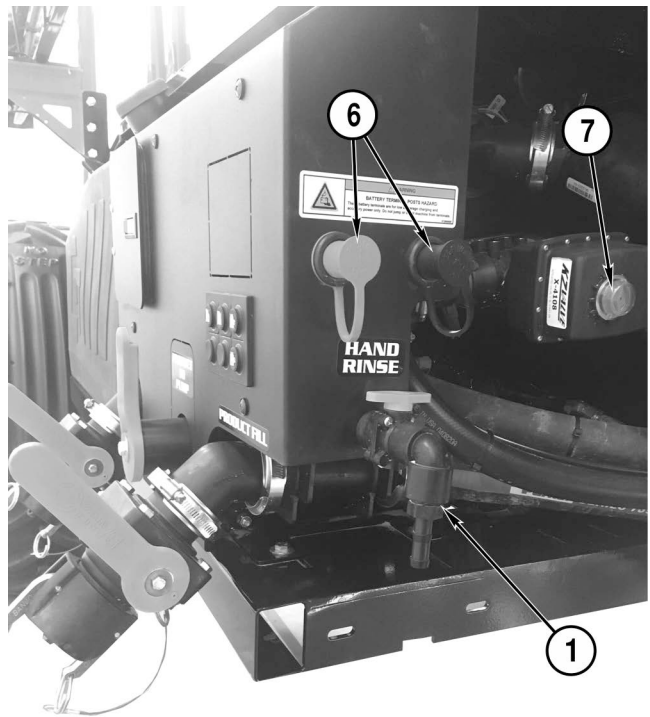
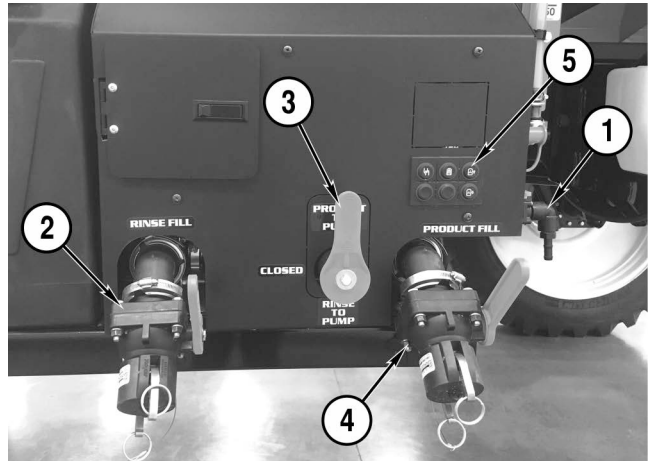

Key Pad Functions

1. Rotoflush Button

When pushed and the LED is green, the Rotoflush is ON. When pushed and the LED is red, the valve is CLOSED.

2. Remote Product Pump Button

When pushed and the LED is blue, the pump is ON. When pushed and the LED is red, the pump is OFF.

3. Increase/Decrease Agitation Button

There are two buttons for agitation. Pushing the top button will increase agitation, and pushing the bottom button will decrease agitation. Agitation can be increased/decreased incrementally by single button pushes, or rapidly by pushing and holding the button.

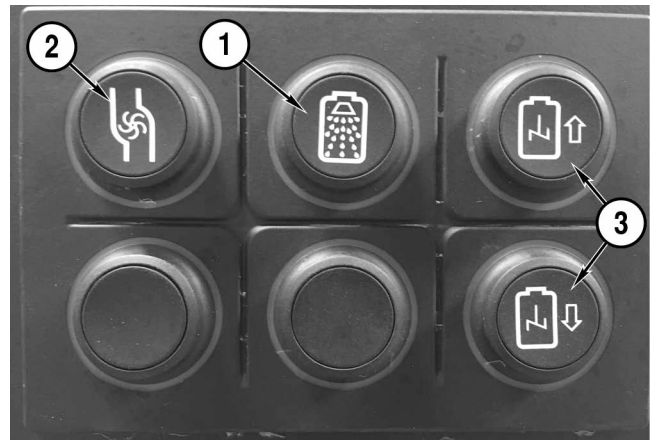

Electric Valve Operation

The electric valve is controlled by buttons on the panel just above the product fill. The buttons are encircled by LEDs that change color depending upon the operation status.

To switch between Rotoflush and agitate valve positions, push the corresponding button.

- Select the Rotoflush (item 1), and the LED will turn green.
- Select either agitate button (item 3) and the LED will turn blue.

When the electric valve is in motion to switch between the functions, the LED will rotate around the button.

- RED indicates an OFF or CLOSED status.
 - GREEN indicates ROTOFLUSH is selected.
 - BLUE indicates AGITATE is selected.
- (See “Button Feature Decal” on page 4-5.)

The control buttons on the fill station panel have corresponding buttons in the cab for remote operation. See “Touch Screen Controls” on page 4-6.

Fill Station - 3 IN Valve with Front Fill

The 3 inch fill station features an electric agitate/Rotoflush valve and an electric rinse/spray valve.

1. **Hand Rinse Valve**
This valve releases water from the dedicated hand rinse tank.
2. **Rinse Tank Quick Fill**
3. **Electric Product Valve**
This valve directs flow from the product tank to the pump or from the rinse tank to the pump.
4. **Product Tank Quick Fill**
5. **Battery Terminals**
Can be used for external pump fill.
6. **Key Pad Electric Valves**
7. **Agitation Valve**
During normal spraying operation, this valve is electronically actuated and controlled by a switch on the side console in the cab.

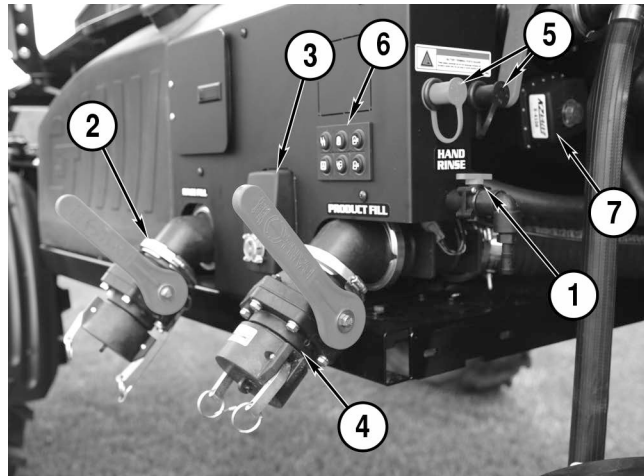

1. **Rotoflush Button**
When pushed and the LED is green, the Rotoflush is ON.

When pushed and the LED is red, the valve is CLOSED.
2. **Remote Product Pump Button**
When pushed and the LED is blue, the pump is ON.
When pushed and the LED is red, the pump is OFF.
3. **Increase/Decrease Agitation Button**
There are two buttons for agitation. Pushing the top button will increase agitation, and pushing the bottom button will decrease agitation. Agitation can be increased/decreased incrementally by single button pushes, or rapidly by pushing and holding the button.
4. **Mode Selection Button**
Toggles between Spray Mode and Rinse Mode.
5. **Electric Rinse/Spray Valve**
Open/Close the valve for the product tank and rinse tank.

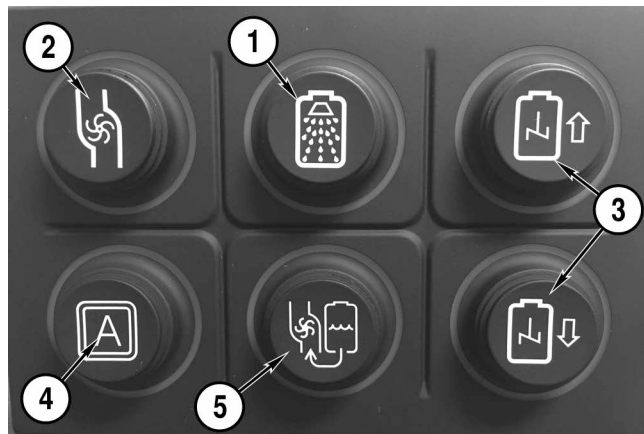

Electric Valve Operation

The valves are controlled by buttons on the panel just above the product fill. The buttons are encircled by LEDs that change color depending upon the operation status.

To switch between Rotoflush and agitate valve positions push the corresponding button.

- Select the Rotoflush (item 1), and the LED will turn green.
- Select either agitate button (item 3) and the LED will turn blue.

When the electric valve is in motion to switch between the functions, the LED will rotate around the button.

- RED indicates an OFF or CLOSED status.
 - GREEN indicates ROTOFLUSH is selected or RINSE is ON.
 - BLUE indicates AGITATE is selected or SPRAY is ON.
- (See “Button Feature Decal” on page 4-5.)

The control buttons on the fill station panel have corresponding buttons in the cab for remote operation. See “Touch Screen Controls” on page 4-6.

3 IN Front Fill

1. Product Tank Fill
2. Flow Meter Bracket
3. Flow Meter Display (option)

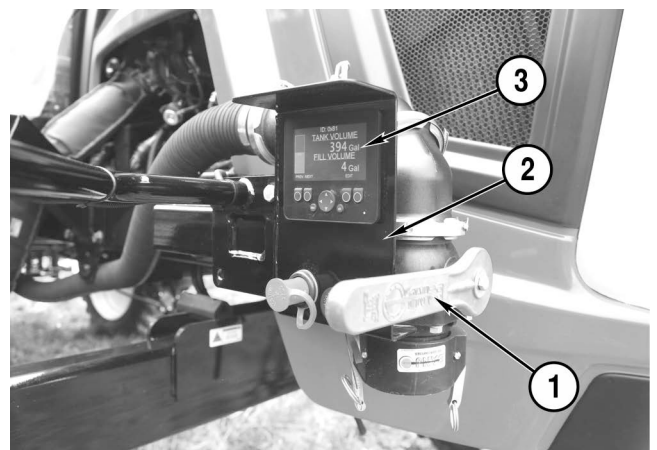

Button Feature Decal

The button feature decal is located on the inside of the glove box door.

The color of the word corresponds to the color of the light around the button when it is in that mode:

1. RINSE: green (G)
2. SPRAY: blue (B)
3. CLOSED: red (R)

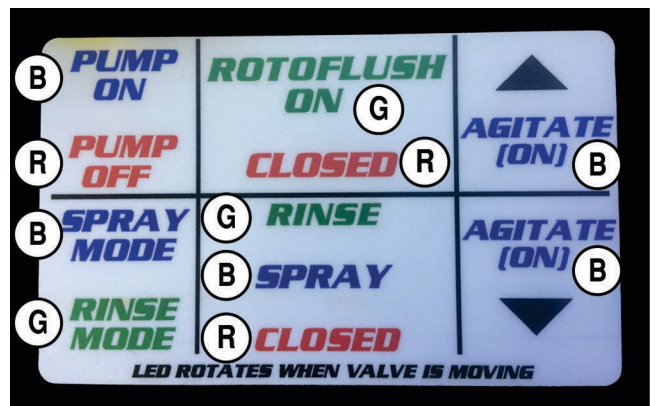

Touch Screen Controls

The touch screen has corresponding controls for the electric agitate/Rotoflush valve.

With the 3 inch option there are additional controls for the electric rinse/spray valve.



Touch Screen and Keypad Summary

The touch screen and fill station keypad can have the selections shown. Touch screen combination correspond with the keypad.

2 in Fill Agitate Pump



2 in Fill Agitate Pump OFF:

- Pump is RED.
- Agitates are BLUE.

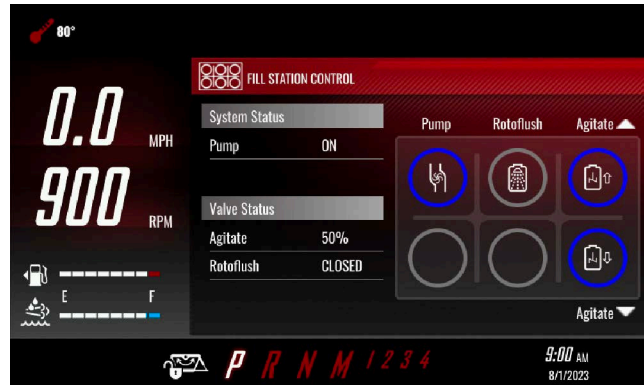

2 in Fill Agitate Pump ON:

- Pump is BLUE.
- Agitates are BLUE.

2 in Fill Rotoflush Pump



2 in Fill Rotoflush Pump OFF:

- Pump is RED.
- Rotoflush is GREEN.



2 in Rotoflush Pump ON:

- Pump is BLUE.
- Rotoflush is GREEN.

3 in Fill Rinse Pump

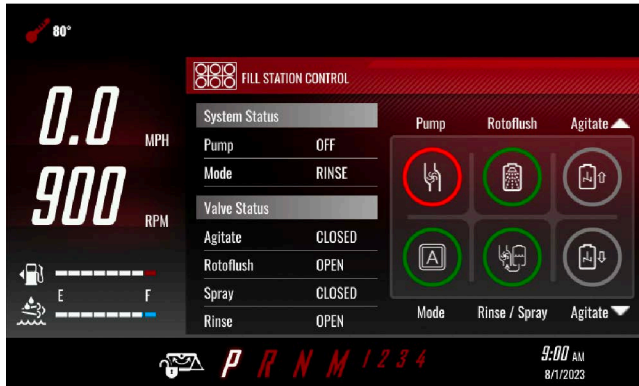

3 in Fill Rinse Pump OFF:

- Pump is RED.
- Mode is GREEN.
- Rotoflush is GREEN.
- Rinse/Spray is GREEN.



3 in Fill Rinse Pump ON:

- Pump is BLUE.
- Mode is GREEN.
- Rotoflush is GREEN.
- Rinse/Spray is GREEN.

3 in Fill Spray Pump

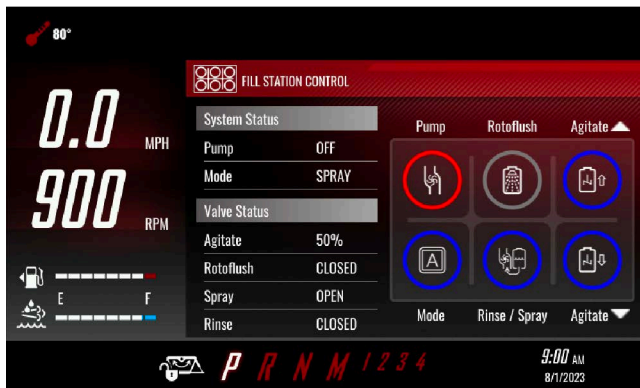

3 in Fill Spray Pump OFF:

- Pump is RED.
- Mode is BLUE.
- Rinse/Spray is BLUE.
- Agitates are BLUE.

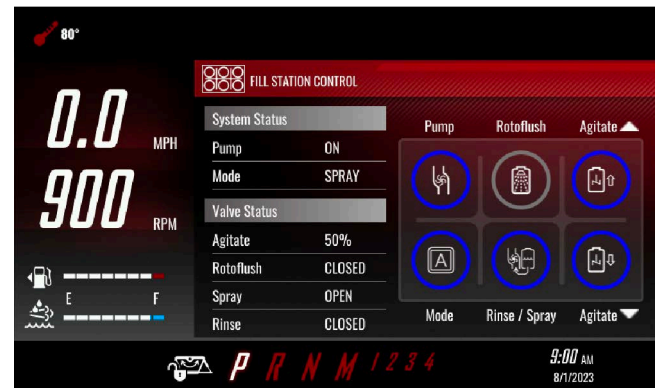

3 in Fill Spray Pump ON:

- Pump is BLUE.
- Mode is BLUE.
- Rinse/Spray is BLUE.
- Agitates are BLUE.

Product Pump and Valves

1. Product Pump

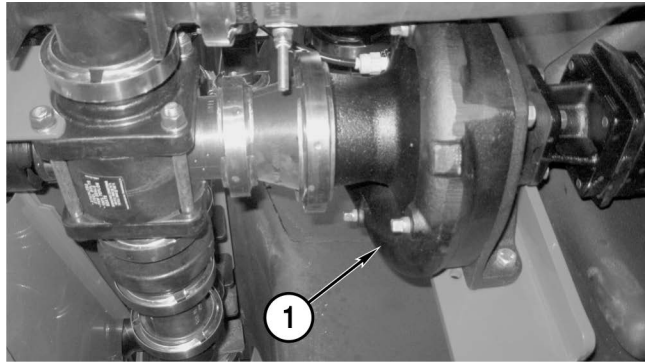

Sump Valve

1. Product Tank Sump Valve Shown in the OPEN position.

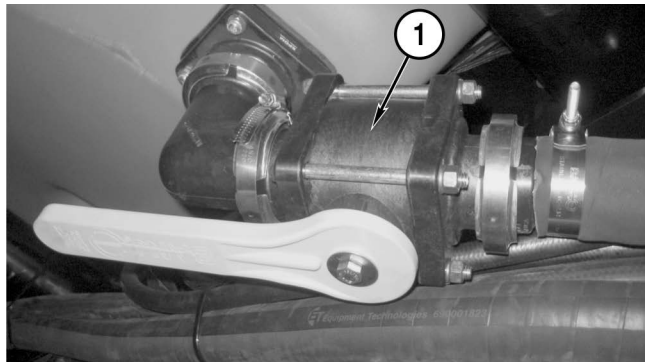

Flow Control

1. Flowmeter

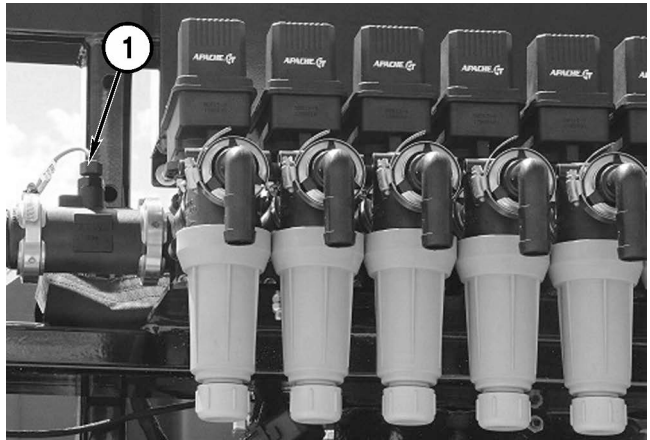

2. PWM Valve

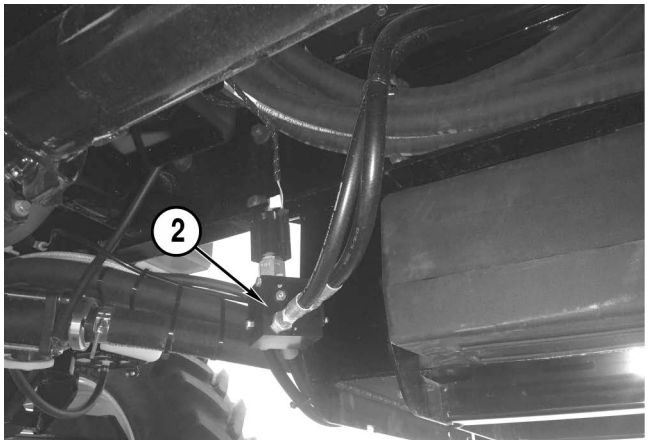

Electronic Boom Valves

The strainers (1) on the electronic boom valves have 50 mesh screens, that must be cleaned periodically.

Note: Apache sprayers equipped with individual nozzle control features will have 80 mesh screens in strainers.

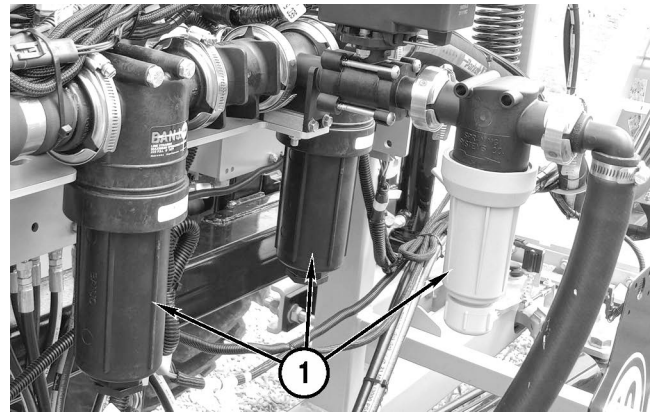

Viper® 4+ Monitor

Viper® 4+ Monitor is the Raven field computer option.

This monitor is built for Equipment Technologies by Raven. See the manufacturer's instructions, provided with the Apache Sprayer, for complete operating, calibration, and service information.



Monitor Calibration Information (for all Raven built monitors)

Speed cal (GPS for speed)1000

Meter cal.....See tag on the flowmeter, located on the rear boom rack.

Boom calThe boom cal numbers are specific for each sprayer and are dependent on the boom width, number of sections and nozzle spacing.

NOTE: All console calibration numbers should be recorded in the Apache owner's manual for future reference.

NOTE: These are factory presets. All controls must be calibrated before applying chemicals.

Side Console

1. Universal Terminal Controller (option)
2. Master Spray Button
3. Boom Rack Buttons
4. Boom Tilt buttons
5. Left/Right Wing Switches
6. Left/Right Tip Switches
7. Agitate Up and Down Switch
8. Product Pump Button

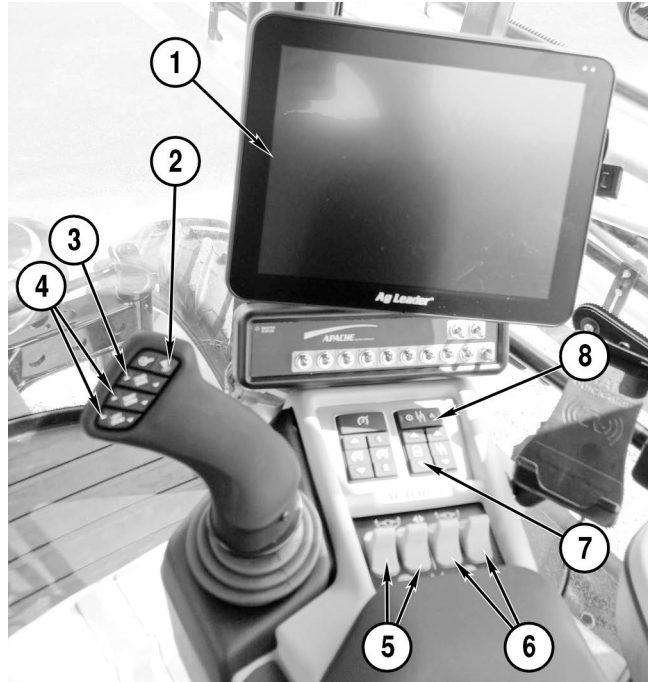

Joystick

1. **Left Boom Tilt**
Press to tilt the left boom up or down. Press the top of the button to raise and press the bottom of the button to lower.
2. **Right Boom Tilt**
Press to tilt the right boom up or down. Press the top of the button to raise and press the bottom of the button to lower.
3. **Boom Center Rack Up/Down**
Press to raise or lower the boom mast. Press the top of the button to raise and press the bottom of the button to lower.
4. **Master Spray Switch**
Press to turn on or off all boom sections that are in the on position on the switchbox.



Filling Product Tank

Open the sump valve (1) on the underside of the product tank.

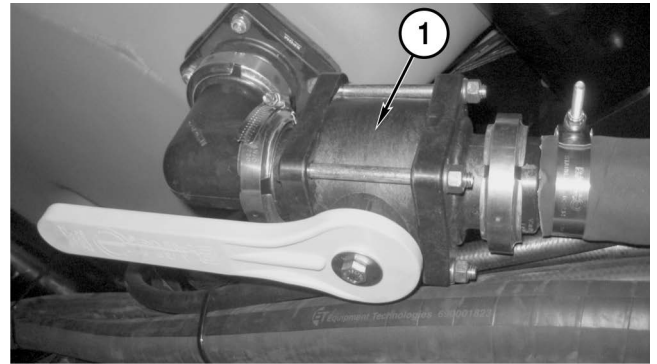

Remove the cap from the product fill inlet (1) and connect the hose from the nurse tank to the inlet.

Open the product fill valve (2), and fill tank to desired level. There is a product tank sight gauge on the front of the tank.

When filling is complete, close the valve on the nurse tank, then close the product fill valve.

Disconnect the hose from the inlet and install the quick fill inlet cap (shown as standard 2-inch fill configuration).

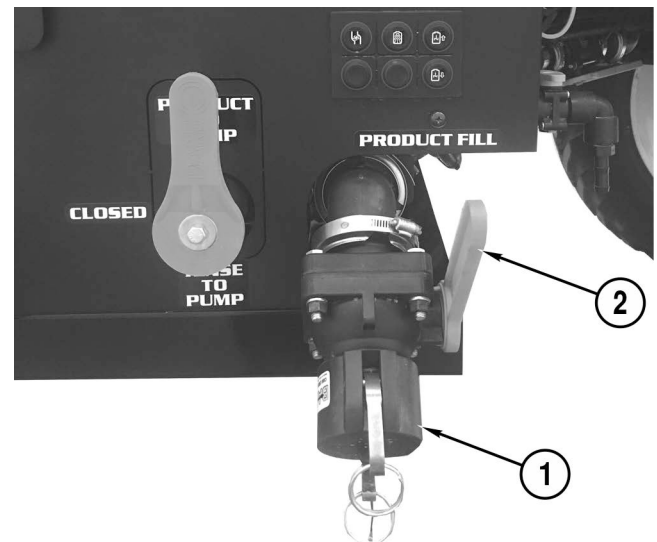

Tank Fill Monitor (optional)

Screen 1:

If equipped the tank fill monitor displays the current tank volume and fill volume. Tank volume can be adjusted manually (see screen 2) if product is added to the tank by means other than through the fill flow meter at the fill station.

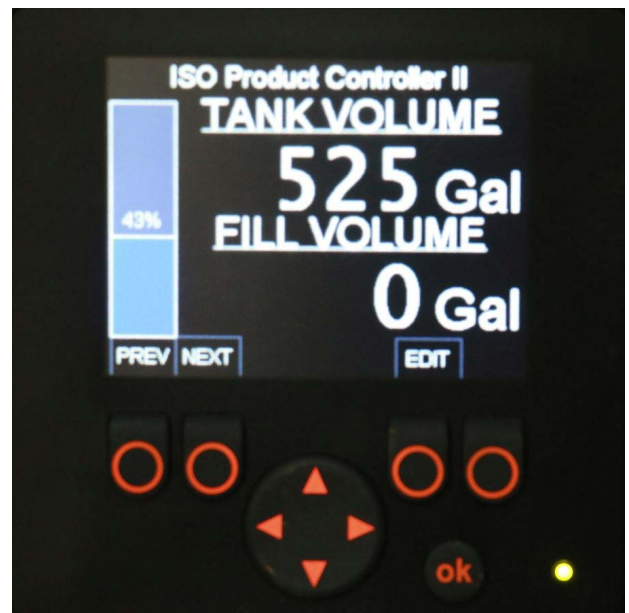

Screen 2:

Use the arrow keys to change the value of the tank volume, if necessary.



Screen 3:

The third screen is for information, including Tank Capacity, Fill Volume, Tank Volume, Sparge Pressure and Flow Rate.



Screen 4:

The fourth screen shows product controller node information and fill meter display information.

Once calibrated, the flow through the secondary flow meter will automatically be added to the tank volume.

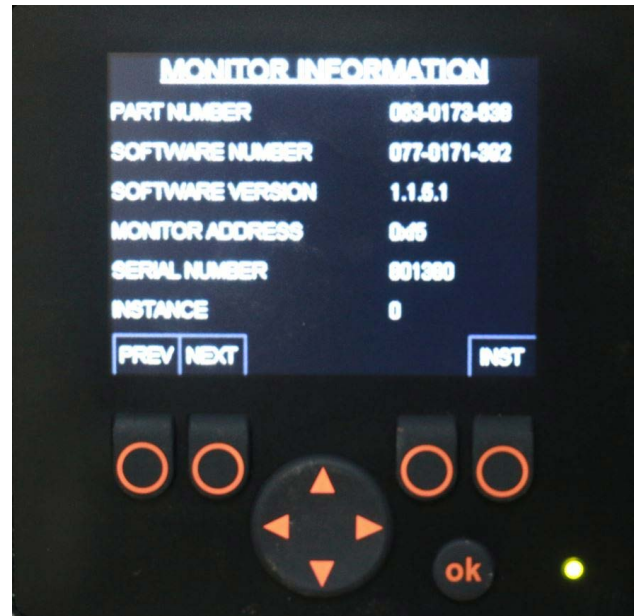

Product Tank Sight Gauge

The product tank sight gauge is located on the side of the fill station leading up to the hand rail above the walking surface. The gauge (1) indicates the amount of product in the tank, beginning at 50 gallons and up to 250 gallons on the side.

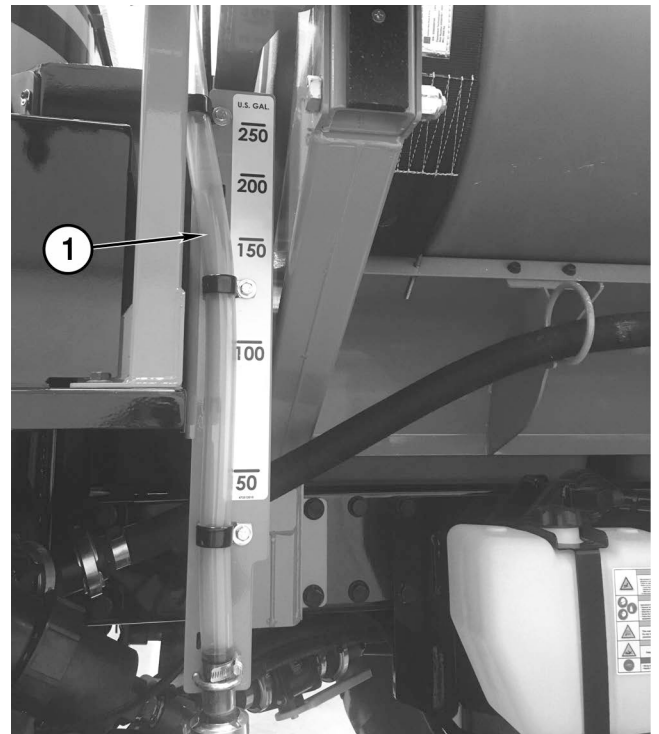

The remaining part of the gauge (2) can be seen from the ground or the cab of the machine. The maximum capacity of the gauge depends on the size of the product tank (800 gallons).

The product tank sight gauge shut off valve is located under the sprayer, on the front left corner of the product tank.

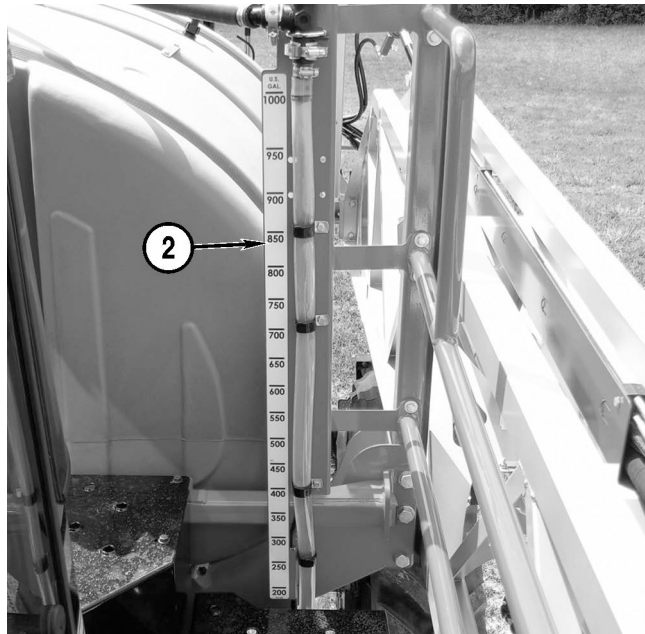

Filling Rinse Tank

Remove the cap from the rinse fill inlet (1) and connect the hose from the nurse tank to the inlet.

Open the rinse valve (2), shown in the CLOSED position and fill to the desired level. There is a tank level indicator tube on the back side of the tank.

IMPORTANT: Fill the tank slowly. Rapid filling or overfilling may rupture the tank.

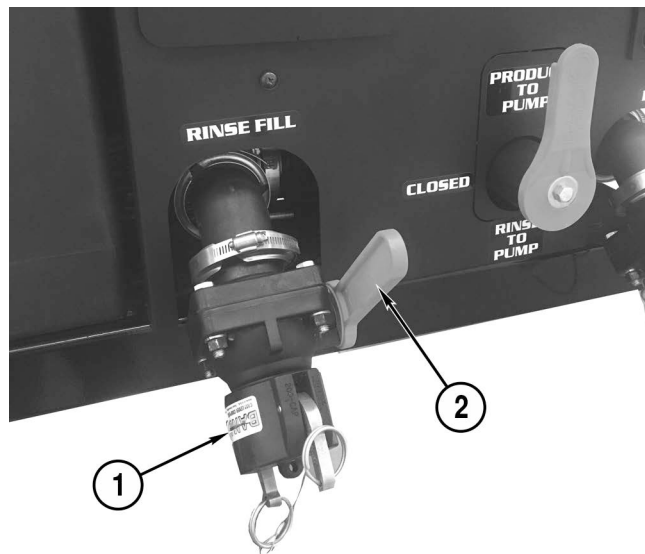

When filling is complete, close the valve on the nurse tank, then close the rinse fill valve.

Disconnect the hose from the inlet and install the fill inlet cap.

Hand Rinse (if equipped)

Unscrew the cap at the center top of the tank (1).

Insert a hose and fill the tank with clean water.

When filling is complete, remove the hose and securely screw the cap onto the tank.

*IMPORTANT: Rinse tank water is **NOT** potable water.*

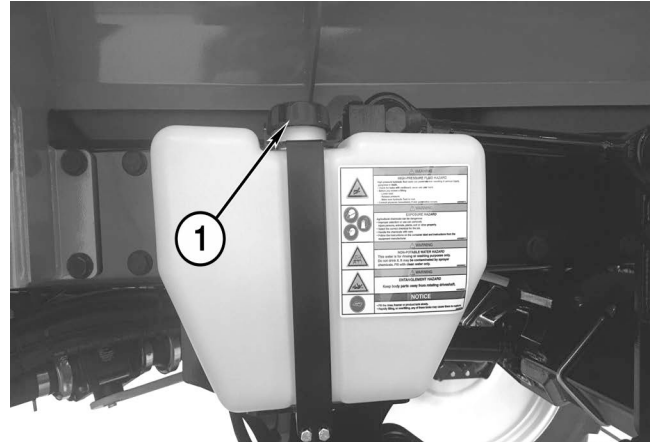

Operating Booms

Before performing any boom operations, read all the following safety messages and take all necessary precautions to avoid personal injury and equipment damage.



WARNING! Electrocutation Hazard. DO NOT fold or unfold the booms near power lines.



WARNING! Control Hazard. NEVER fold or unfold the booms while the Apache Sprayer is moving over 5 mph [8.04 km/h] or with the optional Auto Boom height control turned ON.

Tilt to Remove Boom from the Cradle

All Boom Sizes

On the joystick, press the top of the left (1) and right (2) boom tilt raise/lower switches to raise the booms (3) off of the boom cradles (4).

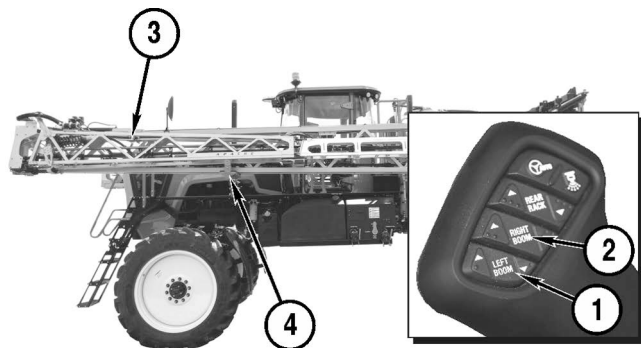

Unfold Boom Wings

NOTICE: Lock boom rack before unfolding. Rack movement could cause damage or injury.

On the console keypad, press the Unfold button (1) to activate. Then press and hold the Left and Right Wing buttons, (2) until the boom wings are fully extended. After the boom wings are fully extended, the boom tips can be unfolded.



Unfold Boom Tips

NOTICE: The booms must be unfolded before the boom tips can be extended. The machine can be damaged if the booms are not unfolded properly.

On the console keypad, make sure the Unfold button (1) is still activated. Then press and hold the Left and Right Tip buttons (2) until the boom tips are fully extended.

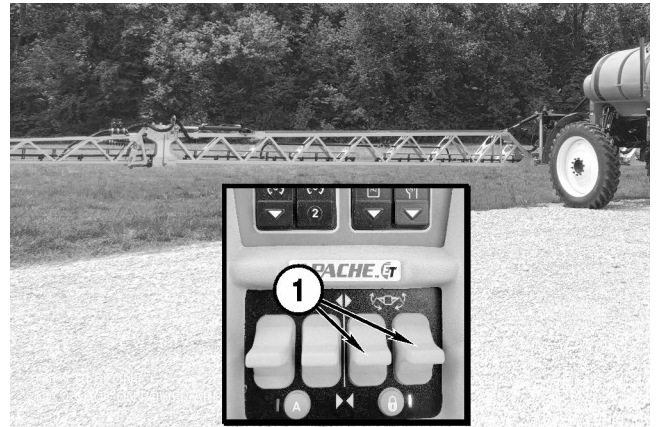

Height Adjustment

On the joystick, press the bottom of the boom rack raise/lower switch (1) to lower the boom rack (2) to the desired height.

Press the top of the switch to raise the boom rack.

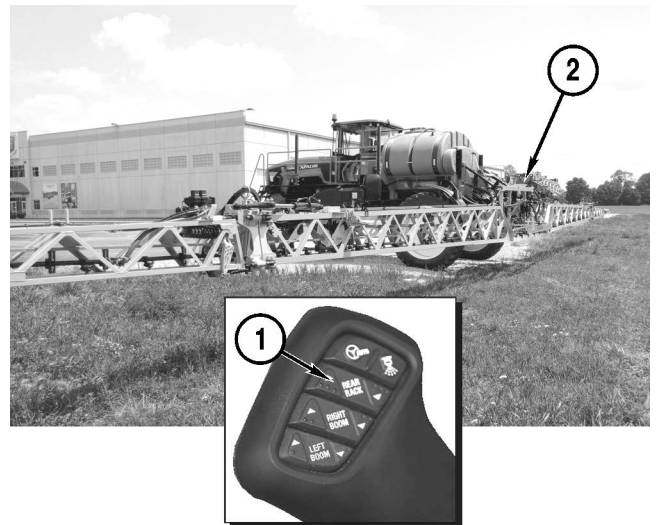

Tilt to Level Boom

On the joystick, use the left (1) and/or right (2) boom tilt raise/lower switches to adjust the booms to level.

Press the top of the switches to tilt the boom up and the bottom of the switches to tilt the boom down.

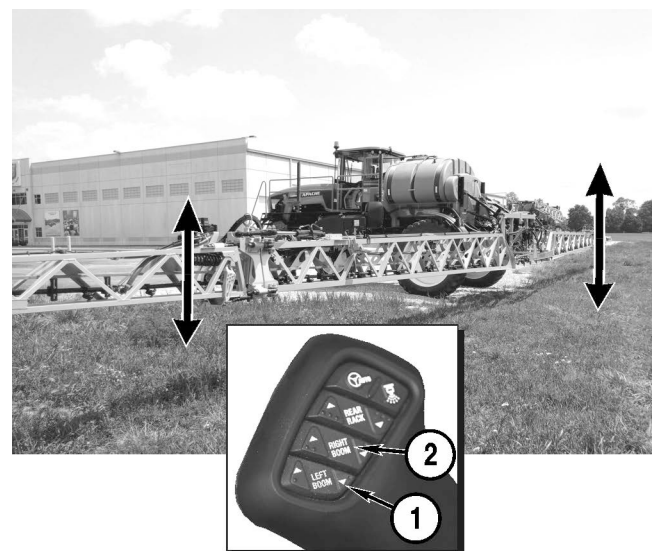

Fold Boom Tips

On the console keypad, press the Fold button (1) to activate. Then, press and hold the Left and Right Tip buttons (2) until the boom tips are fully folded.

After the boom tips are fully folded, the boom wings can be folded.

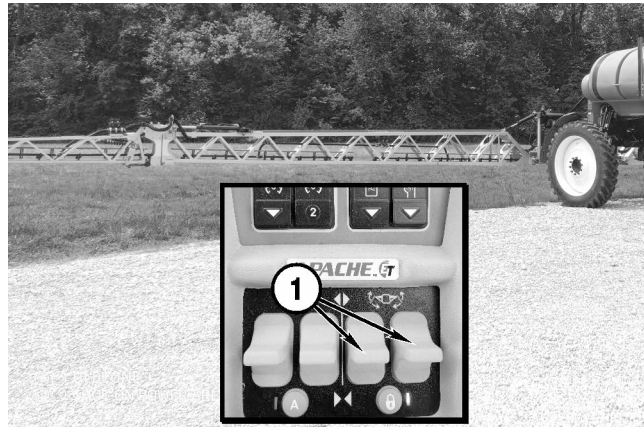

Fold Boom Wings

NOTICE: ALWAYS raise the rack and the left and right boom tips completely before folding the booms.

On the console keypad, make sure the Fold button (1) is activated. Then, press and hold the Left and Right Wing buttons (2) until the boom wings are fully folded.

NOTICE: Lock boom rack before folding. Rack movement could cause damage or injury.



Tilt to Return Boom to Cradle

On the joystick, press the bottom of the left (1) and right (2) boom tilt raise/lower switches to tilt the booms (3) onto the boom cradle (4).

With the booms properly stored, the Apache Sprayer is ready for transport.

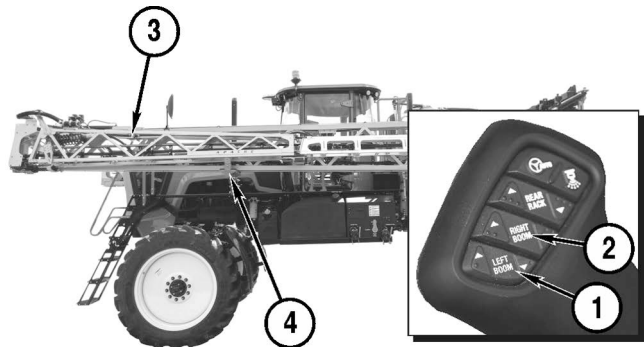

AutoFold (If Equipped)

The AutoFold function is accessed in the touch screen. The autofold icon (1) is located below the speedometer and to the right of the gear indicator.

For ET autofold, diagnostics and calibrations can be found in the settings menu of the display. additional information can be found in this manual under Vehicle Settings.

For Raven AutoFold, supplemental AutoFold information is in the Raven Viper 4+ screen. Refer to the Raven manual for additional information.

The autofold icon appears on the touch screen once AutoFold is unlocked and calibrated.

NOTE: Booms can always be operated with the standard Unfold/Fold functions on the joystick and keypad. Using these buttons will abort the AutoFold function.

NOTE: The Unfold/Fold process will ‘time-out’ when an electrical process is taking too long. The screen will return to the start screen.

NOTE: The end user climate can impact AutoFold performance if it is considerably different from the climate of calibration. Contact dealer if you suspect this performance issue.

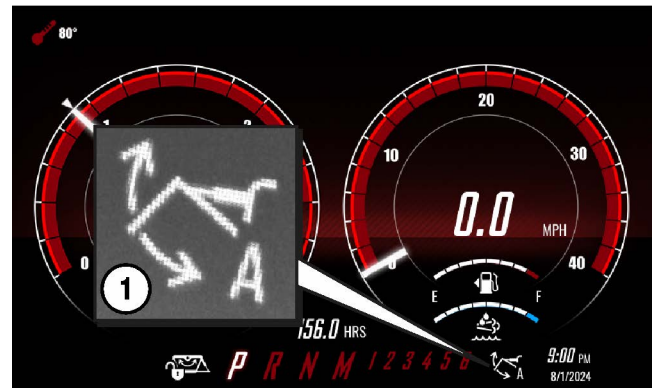

Unfold

1. Touch the AutoFold icon on the touch screen.
2. When the Operator Liability screen appears, read and understand the liability warnings. Touch OK to accept the liability agreement.
3. The Safety Check screen appears next. In order for AutoFold to function the following safety requirements must be met:
 - Speed is zero
 - Brakes are engaged
 - Operator is sitting in seat
 - Rack is level (ET autofold only)

A check mark confirms the requirement has been met.

4. Touch and release the Unfold button. The booms will tilt and unfold automatically.

NOTICE: If any of the safety requirements are not met during unfold or if any boom button is pressed, the function will be aborted.

The unfold function can be reengaged by once again meeting the safety requirements and touching the Unfold button.

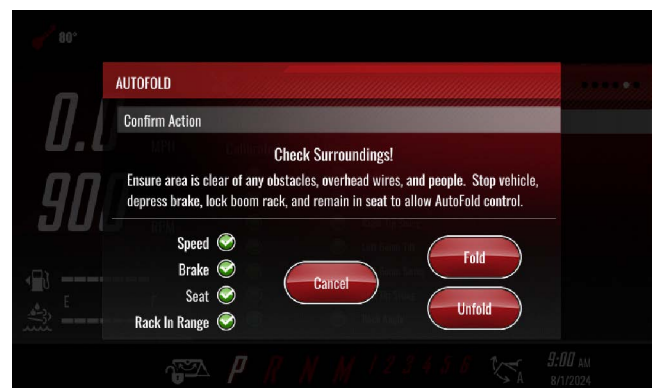
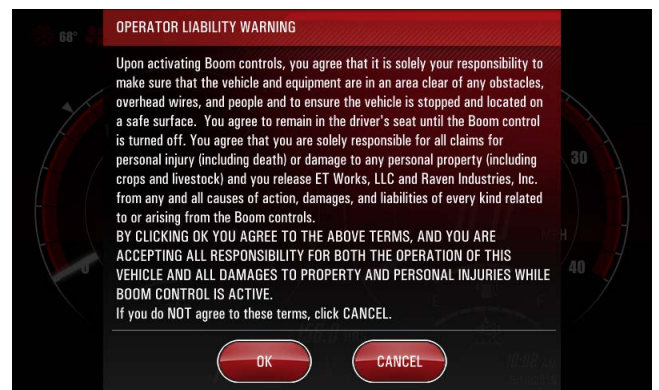

Fold

1. Touch the AutoFold icon on the touch screen.
2. The Safety Check screen appears next. In order for AutoFold to function the following safety requirements must be met:
 - Speed is zero
 - Brakes are engaged
 - Operator is sitting in seat
 - Rack is level (ET autofold only)

A check mark confirms the requirement has been met.

3. **Touch and release the Fold button.**

The booms will fold and return to cradles automatically.

NOTICE: If any of the safety requirements are not met during fold or if any boom button is pressed, the function will be aborted.

The fold function can be reengaged by once again meeting the safety requirements and touching the Fold button.

Spraying

Make sure the product and rinse tanks are filled. See “Filling Rinse Tank” on page 4-14. See “Filling Product Tank” on page 4-11.

Level the booms and boom tips using the tilt and unfold switches. See “Operating Booms” on page 4-16

Set the boom height using the boom rack switch. See “Height Adjustment” on page 4-17.

Open the sump valve (1) on the underside of the product tank.

NOTICE: ALWAYS read and follow all chemical labels and follow all federal and state laws when applying chemicals.

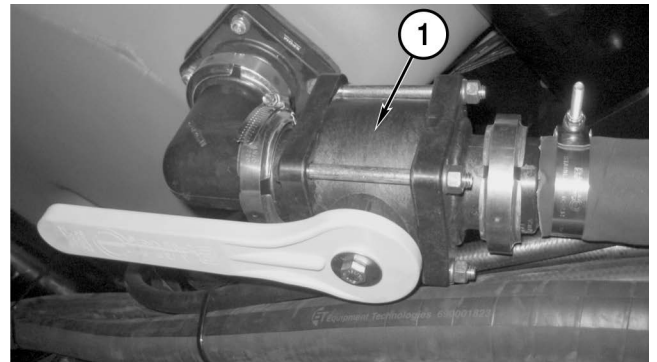

2 Inch Fill

Set the product valve (1) to PRODUCT TO PUMP.

Push either agitation button (2).

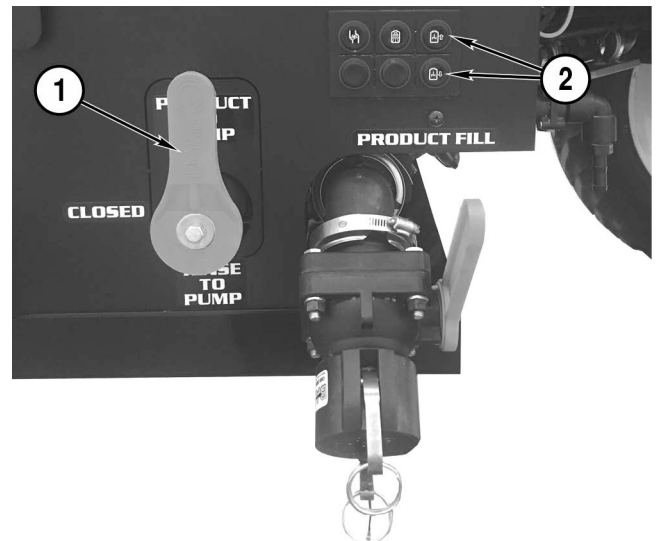

3 Inch Fill

To enable Spray Mode push the Mode button (1) to change the LED to BLUE.

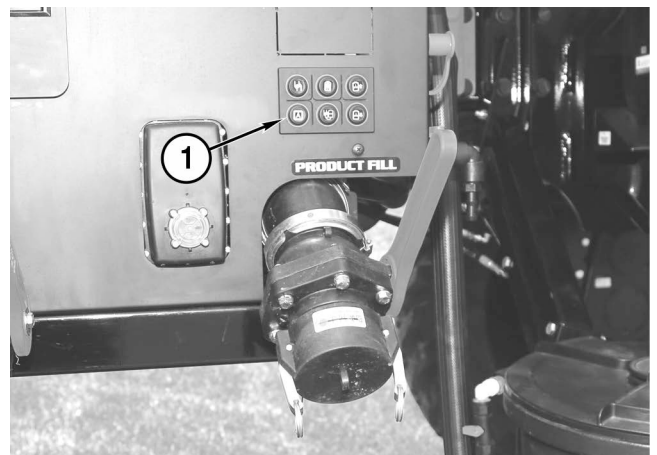

The product strainer (1) features 50 mesh screens, which should be checked and cleaned after every 50 hours of operation or as needed.

The strainer also features a drain valve (2). This valve can be used to ease the draining of the strainer housing before removal for cleaning, or while flushing, or winterizing.

NOTE: Depending on the chemicals being applied, it may be necessary to substitute the 50 mesh screen with a more coarse strainer. See the chemical manufacturer's instructions for complete details.

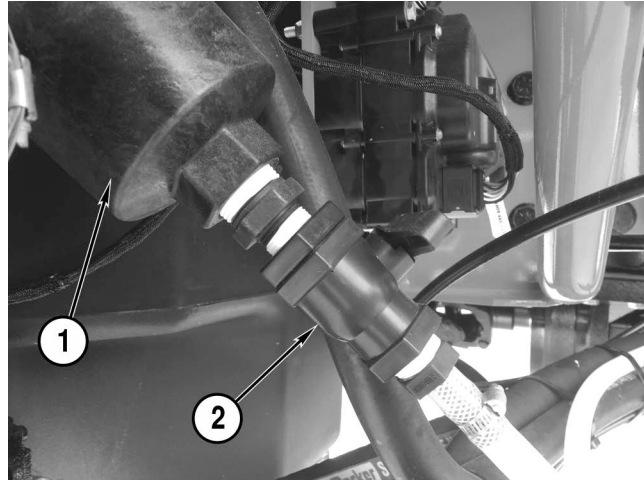

Power up the universal terminal, and check the settings.

Select a saved flow rate or enter the desired rate. See the respective controller's manual supplied with the Apache Sprayer for complete operating instructions.



Set the product pump button (1) to the ON position.

Using the universal terminal, set the desired boom section to the ON position.

IMPORTANT: DO NOT run the product pump dry. Damage to the pump seals will result. DO NOT intentionally dead-head the pump with high pressures. Damage to the pump seals will result. Product pump dead-head pressure with agitation closed should be 120 psi with the hydraulic oil at operating temperature.



Select an appropriate gear for the desired Apache Sprayer speed during spraying.

See “Shifting Forward Gears” on page 3-31. Under typical operating conditions, third or fourth gear is recommended.

Use the master spray on/off button on the joystick (1) to start and stop spraying.

Use the universal terminal to control boom sections to start and stop product flow to individual boom sections if necessary. The console controller will automatically adjust the product flow for the remaining sections.

Use the universal terminal to control the two optional fence row sections.



Quick Spray Mode (Compatible with Raven Spray Control Module Only)

Quick Spray Mode is a simple spraying function that does not use the field computer.

NOTE: Quick Spray will only work if the field computer is OFF or is set to Manual mode.

From the main start screen, swipe left once.

1. Select Quick Spray on the touch screen to go to the parameters screen.
2. The plus (+) and (-) buttons allow the operator to increase or decrease the pump **PWM** by 0.5% increments. Touching and holding the button will allow the value to change quickly.
3. **Boom Pressure**, (psi) as measured by the product controller.
4. **Application Rate**, (gallons/acre) as calculated by the product controller.
5. **Sparge Pressure**, (psi) as measured by the product controller. This can be manipulated by the agitate buttons on the pilot system.
6. **Manual Section Control**, the nine boom sections can be controlled by the corresponding nine triangles when the field computer display is OFF or in Manual mode. Each triangle can be pressed to toggle that section valve on/off. Make sure the Master Spray on the joystick is pushed on. The valve status is indicated by color.

OFF = Gray

ON = Blue (both Master Spray and section valve)

NOTE: If field computer display is ON or in Automatic mode, the triangle icons **cannot** be used to toggle the valves. Color still indicates status of the valve being on or off.

NOTE: The fence row nozzle cannot be controlled with Quick Spray.

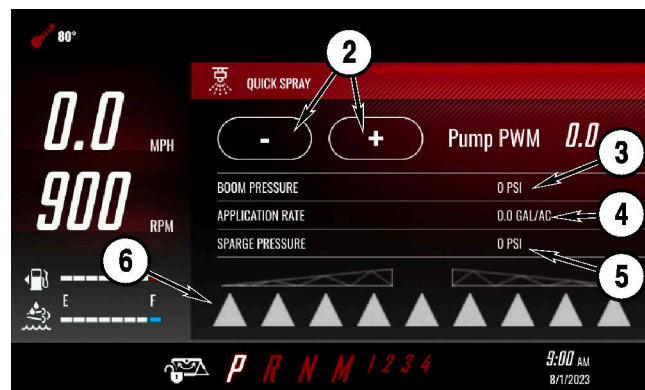
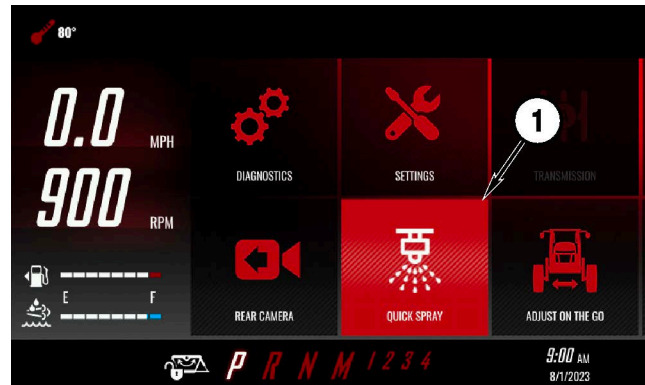

Optional Fence Row Nozzle with Switchbox

The Apache sprayer can be equipped with optional left, and/or right fence row nozzles. If equipped, the fence row nozzles (1) and actuator solenoids (2) are plumbed into the first boom section on the left and the last boom section on the right (left side shown). Therefore, the respective section must be on for the fence row nozzle to operate.

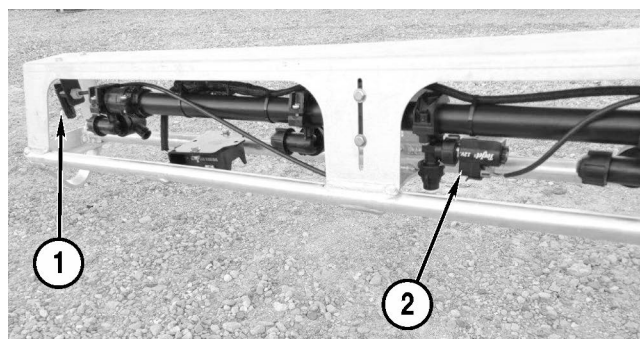

To operate the left fence row nozzle, boom section 1 and boom section L must both be switched on.

To operate the right fence row nozzle, the highest configured boom section and boom section R must both be switched on.

NOTE: For fencerow nozzles without a switchbox, consult Viper manual.

Flushing Product Tank

NOTICE: Read and follow chemical labels for flushing, disposal, and protective clothing requirement instructions.

NOTICE: DO NOT run the product pump dry. Damage to the pump seals will result. DO NOT intentionally dead-head the pump with high pressures. Damage to the pump seals will result.

Fill the rinse tank with clean, fresh, water. See “Filling Rinse Tank” on page 4-14.

2 Inch Fill

Turn the product valve to RINSE TO PUMP (1).

Push the Rotoflush button to ON, LED is GREEN (2).

Start the engine.

Push the product pump button (3) to the ON position, LED is BLUE, and increase the engine speed to approximately 1200 rpm.

NOTICE: The rinse tank will empty quickly. Monitor the process closely to reduce the possibility of running the product pump dry.

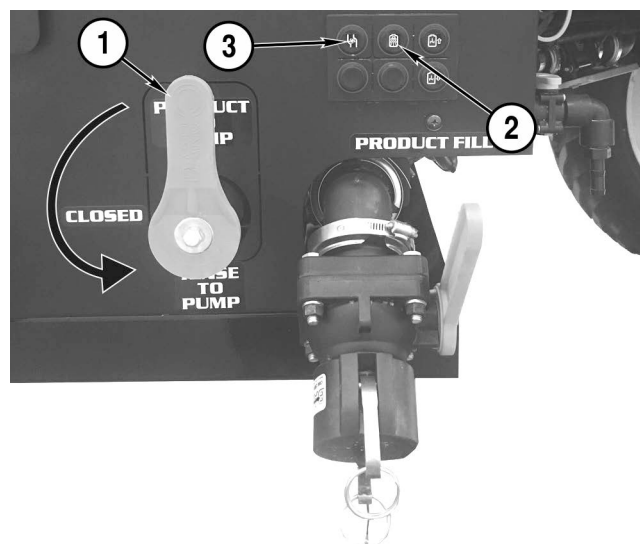

3 Inch Fill

To enable the rinse push the Mode button (1) until the LED is GREEN.

Start the engine.

Push the product pump button (2) to the ON position, LED is BLUE, and increase the engine speed to approximately 1200 rpm.

NOTICE: The rinse tank will empty quickly. Monitor the process closely to reduce the possibility of running the product pump dry.

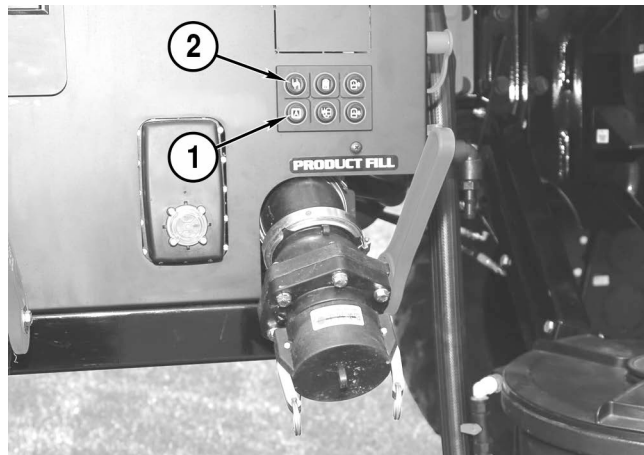

After the tank is rinsed:

- Return the engine to IDLE.
- Set the product pump button (1) to OFF, LED is RED.
- For a **2 inch fill**, move the product valve (2a) to PRODUCT TO PUMP.
- For a **3 inch fill**, push the Rinse/Spray button (2b) to CLOSED, LED is RED.
- Push the Rotoflush button (3) to OFF, LED is RED.
- Drain tank safely through the Product Tank Fill Valve (4).

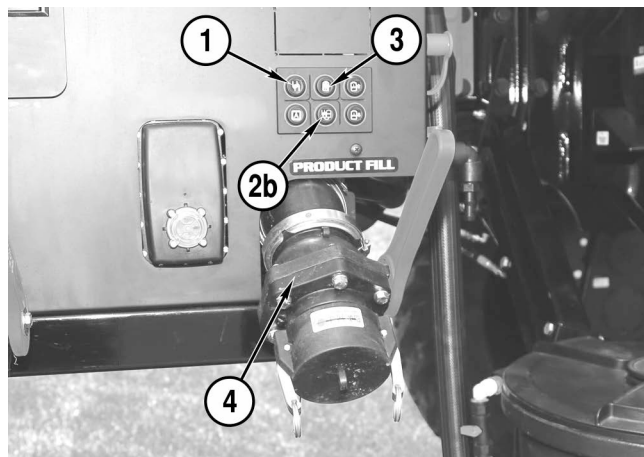
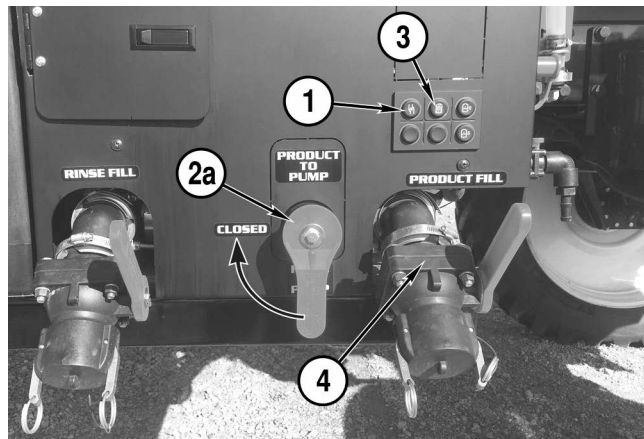

Flushing Booms

NOTICE: Read and follow chemical labels for proper usage, flushing, disposal and protective clothing requirement instructions. ALWAYS dispose of chemicals and contaminated rinse water in a safe location in accordance with chemical label recommendations and local laws.

NOTICE: Some chemicals may require multiple tank flushings.

NOTICE: DO NOT run the product pump dry. Damage to the pump seals will result. DO NOT intentionally dead-head the pump with high pressures. Damage to the pump seals will result.

To flush the booms:

- Unfold the booms.
- For a **2 inch fill**, set the product valve (1a) to RINSE TO PUMP.
For a **3 inch fill**, push Rinse/Spray (1b), LED is GREEN.
- NOTE: To exclusively flush the booms bypassing the product tank, set Rotoflush valve (3) to OFF (LED is RED).
- Remove Hypro Express Endcaps.
- Increase engine speed to 1200 rpm.
- Switch to Manual Spray in the field Computer.
- Push the Product Pump button ON (2), LED is BLUE.
- Press the Master Spray Button to flush.

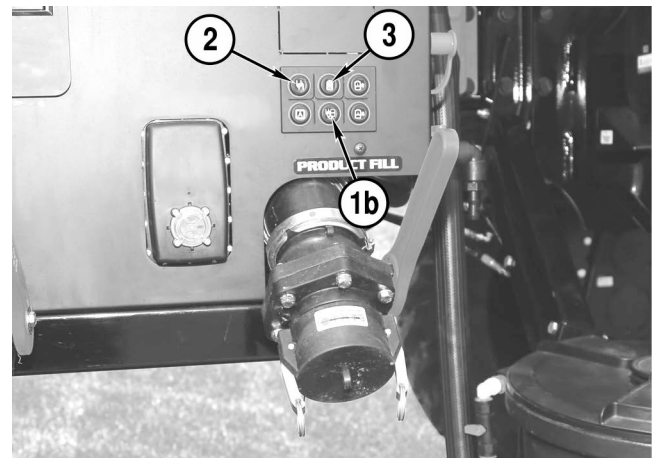
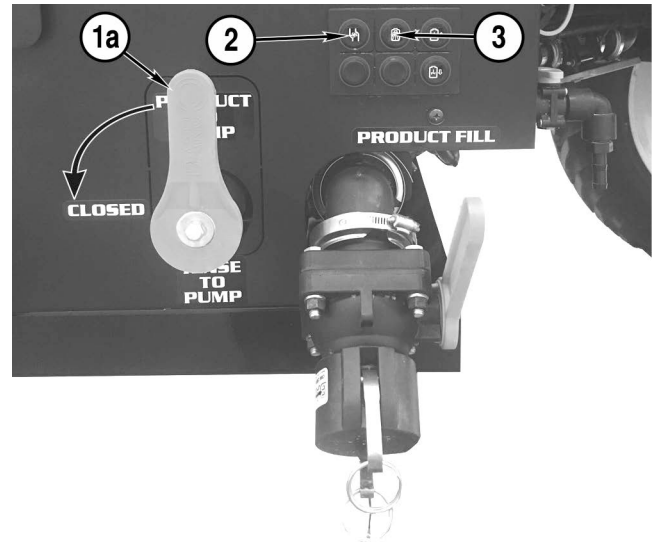

NOTE: If the Apache Sprayer is equipped with an optional chemical eductor, flush the eductor at the same time as the booms.

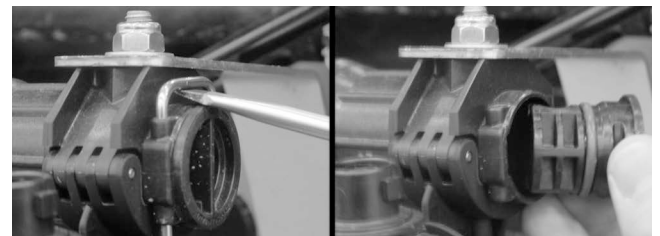

After the booms are flushed:

- Turn OFF Master Spray Button
- Return the engine speed to IDLE.
- Push the product pump button (2) to OFF, LED is RED.
- For a **2 inch fill**, set the product valve (1a) to PRODUCT TO PUMP.
- For a **3 inch fill**, push Rinse/Spray (1b) to OFF, LED is RED.
- Replace the Hypro Express Endcaps
- Fold the booms and turn off the engine.

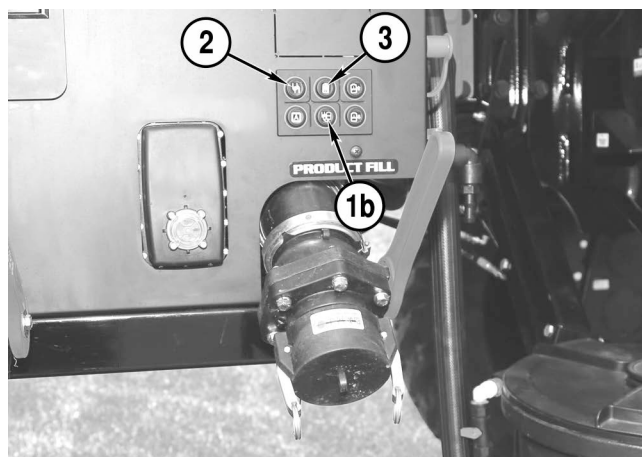
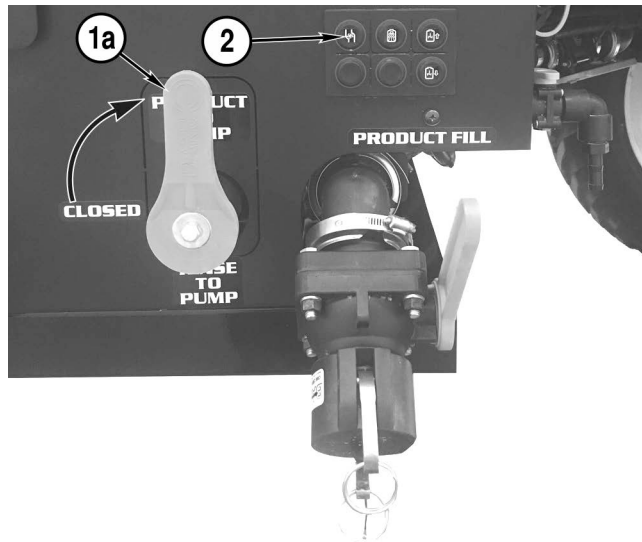

Cleanload Chemical Eductor

The eductor assembly is automatically lowered and raised with the use of the park brake button. When the park brake is activated, the eductor is lowered. When the park brake is deactivated, the eductor is raised.

Startup

1. All eductor valves must be closed prior to starting. Close the inlet ball valve (1) and the hopper ball valve (2).
2. Open the lid to check for foreign objects which may hinder performance or contaminate the system.
3. Close and lock the lid by turning the cover clockwise.
4. Divert pump flow to the eductor inlet line by turning the valve (3) to the open position.

NOTICE: A pressure of 30 psi [2.06 bar] minimum and 150 psi [10.3 bar] maximum must be used. Higher pressures increase eduction rate and available wand suction.



5. Turn the yellow handle of the inlet ball valve (1) to the open position.
6. Open the hopper ball valve (2), located on the bottom of hopper, by rotating the handle into a vertical position.
7. Unlock and open the lid slowly by turning the cover counterclockwise.
8. Load the eductor. Loading instructions differ for eductors equipped with an optional suction lance. Use the procedure that is appropriate for your application.

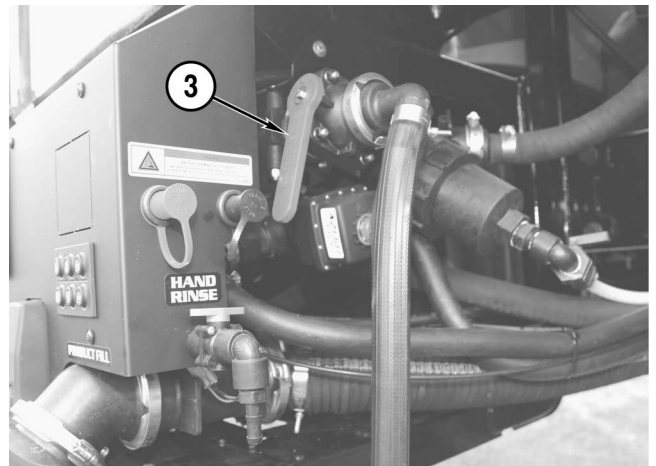

Loading Liquid or Powdered Chemical into Hopper

NOTICE: DO NOT at any point put your face directly over the hopper.

NOTICE: Avoid splashing liquids or powdered chemicals outside of the hopper.

1. Pour required amount of chemical into the hopper.
2. Rinse empty chemical containers if applicable. Place container opening over the container rinse valve and press down. This will activate the rinse valve and rinse the container.
3. Rinse the Cleanload hopper.
4. Close and lock the lid by turning the cover clockwise.
5. Open the eductor valve (3) for 20 seconds, then close the valve.
6. Open the lid and inspect for chemical residue. Repeat steps 3 to 5 as necessary.
7. Close the hopper ball valve (2) by rotating the handle into a vertical position. Turn the inlet valve (1) (yellow handle) off.

NOTE: The eductor hoses are flexible and may be kinked while in the up position. This is normal and will not cause any damage to the hoses or equipment. Make sure that the inlet valve (3) behind the fill station has been shut off before raising the eductor.

Boom Recirculation (Optional Equipment)

If equipped, the sprayer will have boom recirculation plumbing installed allowing for continuous flow of product throughout the boom plumbing.

Operation

When the recirculation system is active, the spray system is not spraying, nozzle control valves (NCVs) are off, and the electric return valve (1) is fully open. The main pump circulates the spray liquid from the main tank through the existing supply plumbing to the section valves.

The section valves turn on and off to circulate fluid for each section of the spray system. This keeps the liquid circulating, allowing the system to purge any air, break up chemical deposits, and agitate any separated chemicals through the system without the need to spray out of the nozzles.

Product returns through the manual throttling valve (4) and electric return valve (1) until spraying resumes.

The manual throttling valve is used to dampen the pressure spike effects of the electric return valve closing when spraying resumes. The individual recirculation hand valves should be used to separate sections when not using nozzle control valves (NCVs) and to isolate boom plumbing sections if maintenance is required or damage has occurred.

NOTE: It is recommended to rinse the system with the boom unfolded to prevent circulating with pinched supply hoses.

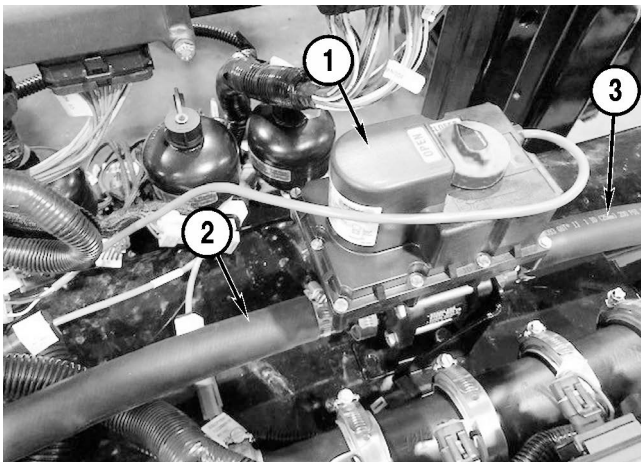

1. Electric Return Valve
2. Hose to Product Tank
3. Hose from Boom Plumbing

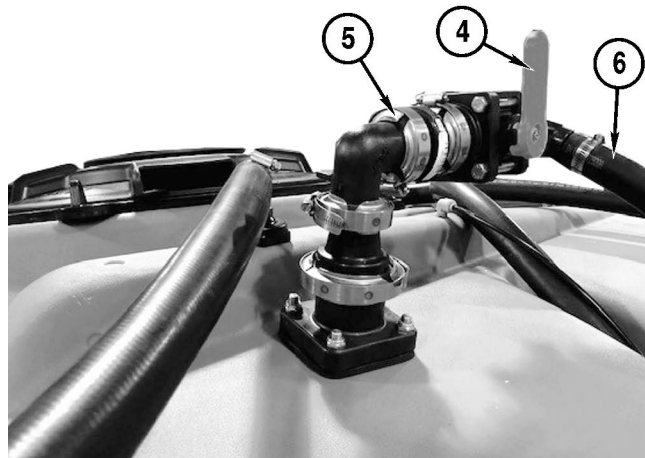

4. Manual Throttling Valve
5. Check Valve
6. Return Hose.

General Boom Recirculation Diagram

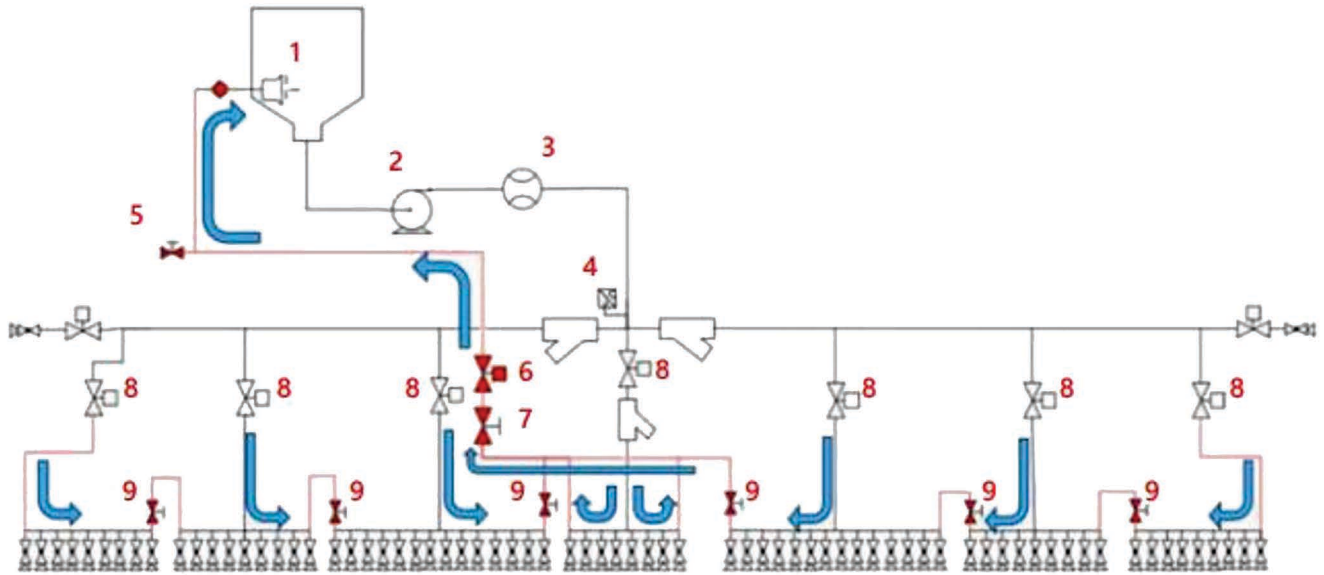

- | | |
|-----------------------------|-------------------------------|
| 1. Main Tank | 6. Electric Return Valve |
| 2. Main Pump | 7. Throttling Valve |
| 3. Main Flow Meter | 8. Section Valves |
| 4. Boom Pressure Transducer | 9. Recirculation Hand Valves. |
| 5. Drain Valve | |

Required Conditions for Recirculation

The following conditions are required to initiate the boom recirculation feature:

- Confirm the Boom Recirculation feature is enabled.
- Ensure the tank fill feature is not enabled.
- Toggle the product pump on.
- Ensure all boom sections are toggled on.
- Ensure the active spray width is zero.
- Recirculation hand valves between sections must be open.
- Either enable the Auto Recirculate feature or manually initiate recirculation on the universal terminal (UT).

Auto-Recirculation

The auto recirculate option allows the system to automatically start the recirculation sequence when the active section application width is zero (all sections turned off). If the auto recirculate feature is not enabled, the operator must activate recirculation manually using a button on the universal terminal (UT).

NOTE: Whether set for manual or automatic recirculation, recirculation will automatically turn off when spraying resumes.

Setup (Raven Boom Recirculation Specific)

To turn on main product recirculation:

1. Open the universal terminal (UT) menu and select the RCM-Sprayer menu button.
2. Select the Tools menu soft key along the right side of the display.
3. Select the Rates Setup tab along the top of the display.
4. Select the User Settings tab and select the Next button in the lower, right corner twice to display the Boom Recirculation check box option.
5. Enable the Boom Recirculation feature.

Setup Enable Main Product Recirculation

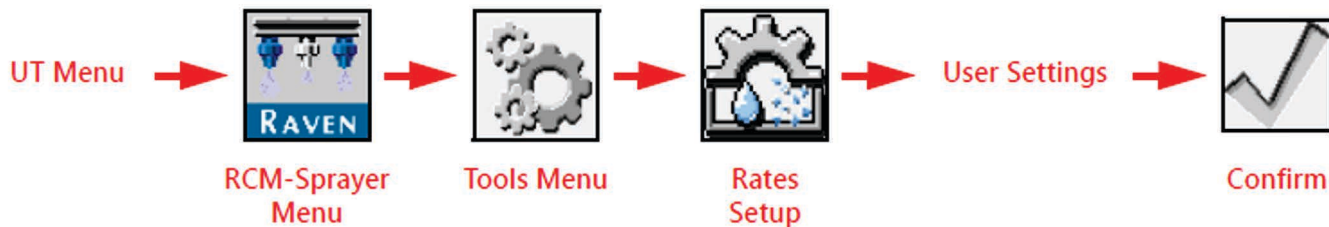

NOTE: The system will display a prompt for the operator to confirm that the plumbing of the system will support boom recirculation features. Once confirmed, the Boom Recirculation soft key will be displayed on the home page.

6. Enable the Auto Recirculate feature to allow the system to automatically initiate the recirculation system anytime the system is not spraying.

NOTE: Recirculation will always stop automatically when normal spraying is initiated, when tank fill operations are started, when the main product is turned off, or when a direct injection product is turned on. The operator may also manually stop recirculation by selecting the Recirculation soft key on the home page. Pressing this button disables the Auto Recirculation feature and returns the system to Manual Recirculation Mode.

7. The Boom Recirculation soft key will be displayed on the universal terminal (UT) home page.



Adjust Recirculation Times

To adjust the time allowed for recirculating each section:

1. Open the universal terminal (UT) menu and select the RCM-Sprayer menu button.
2. Select the Tools menu soft key along the right side of the display.
3. Select the Equipment Setup tab along the top of the display.
4. Use the next button to access the Section Auto-Operation Times page.

5. This page allows the operator to adjust the section recirculation times for the specific application system or current chemical suspension.

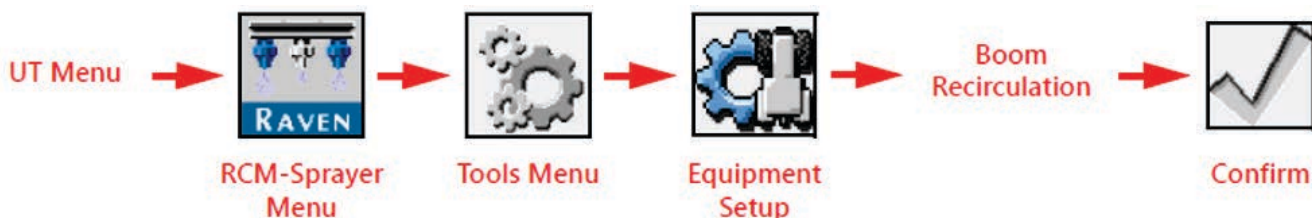

What To Expect While Recirculation Is Active

NOTE: When operating in Auto Recirculation Mode, it is recommended to adjust the Standby PWM% value so that recirculation pressure is close to the application pressure used during application.

When recirculation is active:

- Nozzle Control Valves (NCVs) will remain off.
- The main product pump runs at the “Standby PWM%” value.
- Section valves will cycle “On” sequentially in pairs from the outermost to innermost sections for the user defined recirculation time.
- The system will continue to monitor the main flow meter to ensure product is circulating. If the product recirculation is less than the low limit of the flow meter, the system will display an alert, but recirculation will continue.
- The boom pressure transducer is monitored to ensure the system pressure stays within the minimum and maximum allowable pressures. The main product pump will shut down if the boom pressure exceeds the minimum (2 PSI) or maximum (150 PSI) pressure.
- Section valves will continue to cycle sequentially unless spraying or shutdown conditions are met.
- The drain valve will be used to drain out any product in the recirculation line when rinsing the boom.

See Raven operation manuals for more information.

Setup (CapstanAg PinPoint III Boom Recirculation Specific)

To enable boom recirculation:

Tap Wrench > Pressure > Pump Setup > 2nd Page

Option 13: Recirculation

- OFF - Boom Recirculation will be inactive
- MANUAL - Manually turn on recirculation. Recirculation will turn off automatically when sections turn on
- AUTO - Recirculation automatically turns on when all sections are off
- AUTO DELAY 30s - Automatically turns on after all sections have been off for 30 seconds

Option 14: Recirculation Valve - Ensure this is set to “Normally Closed”.

See CapstanAg Operation manual for more information.

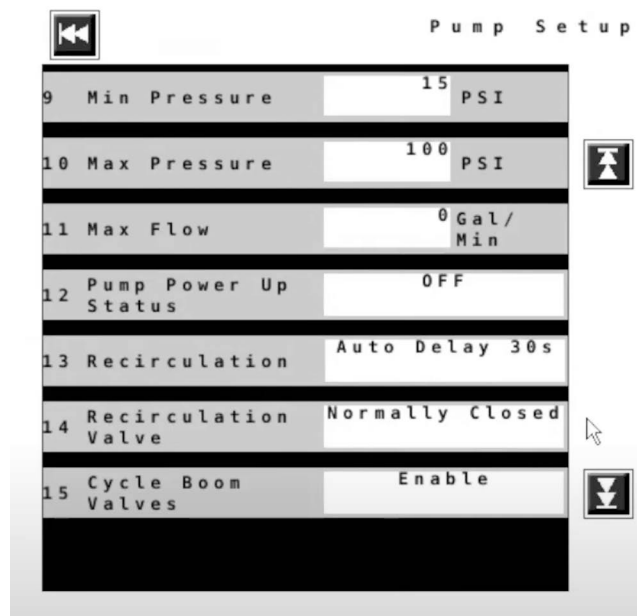

Setup (AgLeader Rightspot Boom Recirculation Specific)

Boom Recirculation Checkbox

To enable Boom Recirculation on the RightSpot Toolbox, check the box.

NOTE: The sprayer must be equipped with boom recirculation plumbing.

Recirculation Start Delay

Set the amount of time to delay recirculation after the system has entered standby mode. When the system enters standby mode, the Start Delay Criteria begins. Once that time has been reached, the boom recirculation will begin.

Section Valves Duration

Enter the amount of time each valve is open during the boom recirculation process.

NOTE: The sprayer must be equipped with boom recirculation plumbing.

To avoid application delays and erratic rates, the user should disable boom recirculation before starting to apply.

See the AgLeader Operation manual for more information.

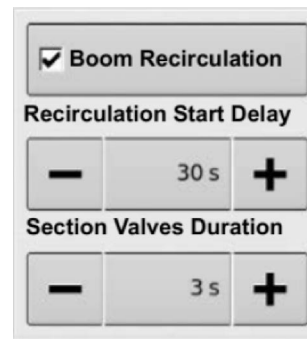

APACHE™

CHAPTER 5

LUBRICATION AND MAINTENANCE

The Scheduled Maintenance Icon will illuminate when maintenance is required.

Before performing any maintenance procedures, read the Safety Section on page 2-1.

Maintenance Precautions

- Parts found defective during inspection or any part whose specifications are not adequate must be replaced.
- ALWAYS tighten components to the specified torque. Loose parts can cause equipment damage or cause it to operate improperly.
- Only use Apache-approved replacement parts. Other replacement parts may affect warranty coverage.
- NEVER attempt to modify the Apache Sprayer design or safety features.
- If a warning alarm or indicator activates during engine operation, stop the Apache Sprayer and engine immediately and contact your Apache dealer. Determine the cause and repair the problem before continuing operation. To ensure your safety, the safety of others, and the safe operation and maintenance of the sprayer, read, follow, and practice the following:



WARNING! Exposure Hazards

- **ALWAYS wear appropriate eye protection to prevent the risk of eye injury. Wear safety glasses to prevent eye contact with debris, chemicals and fluids.**
- **ALWAYS wear ear plugs when working around loud noises to prevent hearing loss.**
- **ALWAYS wear the appropriate gloves to protect your hands, especially when handling extremely hot or cold equipment and fluids.**



WARNING! Entanglement Hazards

- **ALWAYS attach a “Person working on vehicle. DO NOT Start or Operate” tag near the key switch while performing maintenance on the equipment.**
- **ALWAYS stop the engine before beginning service.**
- **NEVER operate the engine without the guards in place.**
- **ALWAYS remove any tools or shop rags used during maintenance from the area before operation.**
- **NEVER engage the transmission or driven equipment by hand from underneath the Apache Sprayer when the engine is running.**



WARNING! Piercing Hazards

- **Avoid skin contact with high-pressure diesel fuel spray caused by a fuel system leak such as a broken fuel injection line. High-pressure fuel can penetrate your skin and result in serious injury. If you are exposed to high-pressure fuel spray, obtain prompt medical treatment.**
- **NEVER check for a hydraulic leak with your hands. ALWAYS use a piece of wood or cardboard.**

**WARNING! Flying Object Hazard.**

- **ALWAYS** wear eye protection when servicing the engine or when using compressed air or high-pressure water. Dust, flying debris, compressed air, pressurized water or steam may injure your eyes.

**WARNING! Crush Hazards**

- **ALWAYS** make sure the Apache Sprayer is on flat, solid ground before getting under the Apache Sprayer.
- **ALWAYS** block front and rear axle wheels before getting under the Apache Sprayer.
- If using a hydraulic jack or jack stands, ensure they are of the proper capacity and used in a proper manner under the frame of the Apache Sprayer.
- Use a hoist or use assistance when lifting components that weigh 50 lb [23 kg] or more. Make sure all lifting devices such as chains, hooks or slings are in good condition, of the correct capacity, positioned correctly and have current, valid inspection labels.
- **ALWAYS** use lifting equipment with sufficient capacity to lift the Apache Sprayer or equipment.
- If transport is needed for repair, acquire assistance when using a hoist and when loading and unloading.

**WARNING! Fire/Explosion Hazards**

- While the engine is running or the battery is charging, hydrogen gas is being produced and can be easily ignited. Keep the area around the battery well-ventilated and keep sparks, open flame and any other form of ignition out of the area.
- **ALWAYS** turn off the battery switch or disconnect the negative (-) battery cable before servicing the equipment

**WARNING! Explosion Hazard.**

- Batteries contain sulfuric acid. **NEVER** allow battery fluid to come in contact with clothing, skin or eyes. Severe burns could result. If battery fluid contacts the eyes and/ or skin, immediately flush the affected areas with a large amount of clean water and obtain prompt medical treatment.

**WARNING! Exposure Hazard.**

- **ALWAYS** wear safety goggles and protective clothing when servicing the battery.

**WARNING! High-Pressure Compressed Air - Exposure and Impact Hazards**

- Pneumatic components store compressed air and can separate violently during disassembly or removal. Before servicing any part of the pneumatic (air) system, slowly release all compressed air from the system.
- **NEVER** exceed the recommended working air pressure.
- **NEVER** connect or disconnect a hose or line containing air pressure.
- **ALWAYS** wear safety glasses when working with compressed air systems. **NEVER** look into the area of escaping air when draining air tanks or disconnecting lines. Dirt or moisture may be expelled, causing eye injury.

**WARNING! Shop Equipment Hazards**

- **ALWAYS check before starting the engine that any tools or shop rags used during maintenance have been removed from the area.**
- **ALWAYS use tools appropriate for the task at hand and use the correct size tool for loosening or tightening machine parts.**
- **ALWAYS use the proper tools and equipment for servicing the Apache Sprayer. Ensure the tools are rated and approved for use with this Apache Sprayer.**
- **If an Apache Sprayer is to be operated with test equipment connected, precautions must be taken to ensure that all equipment and related components are securely attached to prevent movement and interference.**
- **Before performing any maintenance procedure, have all the correct tools you need to perform the required tasks.**
- **Ensure that the work area is adequately illuminated. ALWAYS install wire cages on portable safety lamps.**

Environmental Precautions

The safety messages that follow have NOTICE level hazards.

- Thoroughly clean any spilled fluids from the equipment and/or ground after service is completed. Dispose of used fluids and filters as required by law.
- ALWAYS be environmentally responsible. Follow the guidelines of the EPA or other governmental agencies for the proper disposal of hazardous materials such as engine oil, diesel fuel and engine coolant. Consult the local authorities or reclamation facility.
- NEVER dispose of hazardous materials by dumping them into a sewer, on the ground, or into ground water or waterways.

Non-Apache Equipment Maintenance

Some components and systems of Apache Sprayers are manufactured by companies other than Apache and have specific safety, inspection, adjustment and maintenance procedures outlined by their manufacturer.

NOTICE: *ALWAYS perform maintenance procedures for all OEM equipment in addition to procedures for the Apache Sprayer.*

Some non-Apache equipment operator's and maintenance manuals are included with the Apache Sprayer. These include, but are not limited to, the Engine Owner's Manual, Sprayer Monitor System Manual, Chemical Educator Manual, Product Pump Instructions and other optional equipment manuals.

NOTICE: *ALWAYS perform and reference the original equipment manufacturers' service information when performing service or maintenance procedures on equipment manufactured by companies other than Apache. Before servicing original equipment manufacturer (OEM) systems or components, properly identify the OEM model and serial number to ensure correct service and replacement part information is referenced.*

Cleaning Guidelines

The following guidelines are recommended when cleaning mechanical and electrical parts of the cab.



WARNING! Fire Hazard

- *Cleaning solvents can cause death or serious injury.*
- *Cleaning solvents are extremely flammable and toxic if inhaled.*
- *DO NOT use near sparks or flame and avoid inhaling.*
- *Use in a well-ventilated area and follow the manufacturers' warnings on use and handling.*



WARNING! Exposure Hazard.

- *Wear safety glasses, gloves, and other proper protective clothing or gear when handling part cleaners or other hazardous cleaning agents.*

The safety messages that follow have *NOTICE* level hazards.

- Use caution when using power washers to avoid damaging rubber, plastic or electrical components.

Mechanical Parts

- Clean mechanical parts with a noncombustible cleaning agent.
- Clean mating surfaces thoroughly after removing a part to which an O-ring or gasket is attached. If you replace a part, ALWAYS use a new O-ring or gasket.

Electrical Parts

- NEVER spray water or cleaners directly on electrical parts.
- Electrical parts are susceptible to water damage and insulations leaks. Current leakage can develop if electrical parts become wet or the insulation is damaged.

Body and Cab Exterior

- The use of a low-pressure water supply system and mild automotive-type soap is recommended to wash and rinse the Apache Sprayer.
- DO NOT use abrasive cleaning materials on the Apache Sprayer, as brushes, chemicals and cleaners may damage the finish or components.
- DO NOT remove ice or snow from painted surfaces with a scraper or blade.
- DO NOT allow diesel fuel, oils, lubricants or antifreeze to come in contact with painted surfaces.
- When cleaning chrome, stainless-steel or aluminum parts, use clean water and a soft cloth.
- Avoid scratching or damaging polished metal finishes; DO NOT use abrasive cleaners.
- NEVER use pressurized water or cleaners to clean the cab interior.
- NEVER use corrosive cleaning solutions or any type of abrasives. Part or equipment damage caused by use of corrosive cleaners or abrasives is not covered under Apache warranty.
- Periodically clean the interior dash, gauge panels, floor and seat with a mild cleanser or water-dampened cloth.
- Periodically clean all interior glass with a water-dampened cloth or approved glass cleaning materials.

Apache Sprayer Service Interval Chart

Perform and repeat the prescribed maintenance at each interval ○ = Conditional Service ● = Regular Service ▲ = Required 100 Hour Service NOTE: DO NOT overlook the "At 100 Hours" interval.	Before Initial Use	After First 10 Hours	As Required	Daily	Every 40 Hours	After First 100 Hours	Every 100 Hours	Every 250 Hours or Yearly	Every 500 Hours or Yearly	Every Year	Every 1000 Hours or Yearly	Every 4500 Hours or 3 Years
Grease Boom	○			●								
Grease Boom Fold Cylinder	○			●								
Adjust Poly Tank Straps	○	○			●							
Torque Lug Nuts	○	○			●							
Grease Steering Components	○				●							
Grease Axle Components	○				●							
Grease Driveline Components	○						●					
Torque Axle Extension Bolts	○		○				●					
Adjust Boom	○	○	○									
Clean Primary Engine Air Filter			○									
Change Primary Engine Air Filter								●				
Change Engine Safety Air Filter			○							●		
Adjust Toe-In			○							●		
Winterize Wet System										●		
Flush Wet System (including product pump)			○	●								
Check Tire Pressure				●								
Check Oil Engine Level				●								
Drain Water from Primary Fuel Filter				●								
Check Coolant Level, Cooling Package, and Hoses				●								
Check Transmission Fluid Level				●								
Check Hydraulic Fluid Level				●								
Re-Phase Steering Cylinders (adjustable axles)				●								
Grease Front Strut and King-pins					●							
Grease Rear Suspension					●							
Check Differential Fluid Level					●							
Check Differential for Leaks					●							
Check Final Drive Fluid Level					●							
Check Final Drives for Leaks					●							

Perform and repeat the prescribed maintenance at each interval ○ = Conditional Service ● = Regular Service ▲ = Required 100 Hour Service NOTE: DO NOT overlook the "At 100 Hours" interval.	Before Initial Use	After First 10 Hours	As Required	Daily	Every 40 Hours	After First 100 Hours	Every 100 Hours	Every 250 Hours or Yearly	Every 500 Hours or Yearly	Every Year	Every 1000 Hours or Yearly	Every 4500 Hours or 3 Years
Change Differential Fluid						▲		●				
Change Hydraulic Fluid Filter (Immediately if indicated by console screen)						▲		●				
Change Primary Fuel Filter						▲			●			
Change Secondary Fuel Filter						▲			●			
Change Engine Oil and Filter						▲			●			
Change Transmission Fluid and Filter						▲			●			
Change Final Drive Fluid (drop box or planetary)						▲			●			
Change Cab Filter (charcoal filter)									●			
Inspect Front Accumulator and Suspension Cylinder									●			
Check Front Suspension Accumulator Charge									●			
Check Rear Suspension Cylinder and Accumulator Charge									●			
Inspect and Repack Wheel Hub and Flex Bearings									●			
Change Hydraulic Fluid											●	
Change DEF Tank Filter											●	
Change DEF Supply Module Filter												●

Before Initial Use

The following services must be performed before initial use of the Apache Sprayer and repeated at the interval prescribed in the Apache Sprayer Service Interval Chart. See “Apache Sprayer Service Interval Chart” on page 5-5.

- Torque Lug Nuts. See “Torque Lug Nuts” on page 5-17.
- Grease Boom. See “Grease Boom” on page 5-11.
- Torque Axle Extension Bolts. See “Torque Axle Extension Brace Bolts” on page 5-24.
- Grease Steering Components. See “Grease Front Axle Assembly” on page 5-18.
- Grease Axle Components. See “Grease Axle Components (adjustable only)” on page 5-19.
- Grease Driveline. See “Grease Driveline Components” on page 5-23.
- Adjust Poly Tank Straps. See “Adjust Poly Tank Straps” on page 5-17.
- Adjust Boom. See “Adjust Boom” on page 5-7.

After First 10 Hours

The following services must be performed after the first 10 hours of operation and repeated at the interval prescribed in the Apache Sprayer Service Interval Chart. See “Apache Sprayer Service Interval Chart” on page 5-5.

- Torque Lug Nuts. See “Torque Lug Nuts” on page 5-17.
- Adjust Poly Tank Straps. See “Adjust Poly Tank Straps” on page 5-17.

Adjust Boom

NOTICE: All boom adjustments should be performed with the boom fully unfolded and lowered.

Boom Lead Adjustment

1. Unfold the boom wings and boom tips, then lower the back rack.

2. Loosen the 3 bleed screws (1) for the boom fold and cushion circuits.

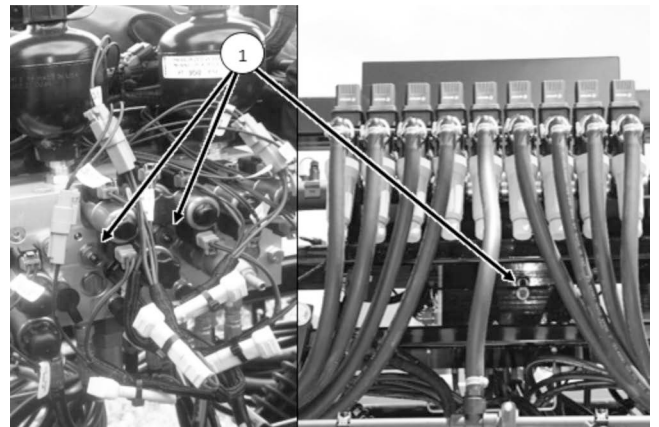

3. Loosen the jam nut (1) on the fold cylinder cushion rod.
4. Rotate the fold cylinder cushion rod (2) to adjust the boom lead. Decreasing the number of visible threads on the fold cylinder clevis will reduce the boom lead. Increasing the number of visible threads on the fold cylinder clevis will increase the boom lead.
5. After adjusting the boom lead so that the tips are even with the back rack, tighten the jam nuts (1).

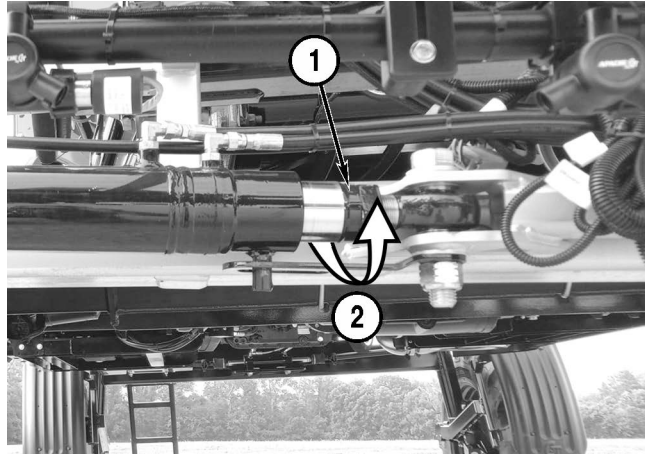

6. Tighten the three bleed screws (1) and their jam nuts.

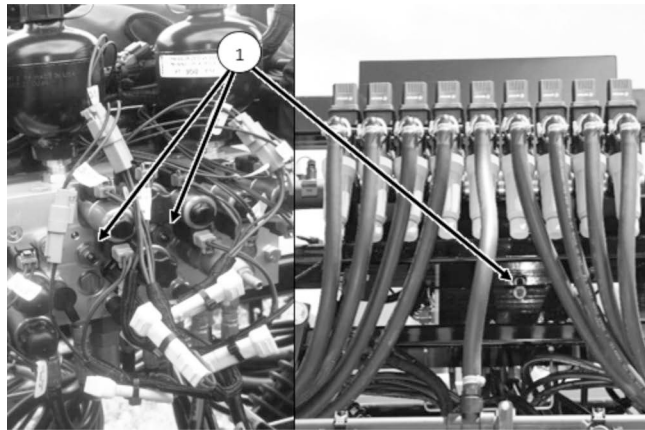

7. To check the boom lead adjustments, raise the back rack and fold the booms all the way in. Then repeat the unfold process and recheck the boom lead. Readjust if needed.



Boom Stabilizer

There are two boom stabilizers mounted on the boom rack. The upper and lower right-side stabilizers (1) are shown.

The gap between the nylon wear pads and the steel frame should be 0.039 to 0.079 in. [1 to 2 mm] with the booms unfolded.

To adjust the gap:

1. Loosen both lock nuts (2) on the stabilizer and equally adjust the jam nuts (3) until the gap is correct.
2. Tighten the lock nuts (2).
3. Repeat the steps for the other stabilizers, as required.

NOTE: For best performance, the jam nuts must be adjusted so the stabilizer halves are parallel and provide the recommended gap.

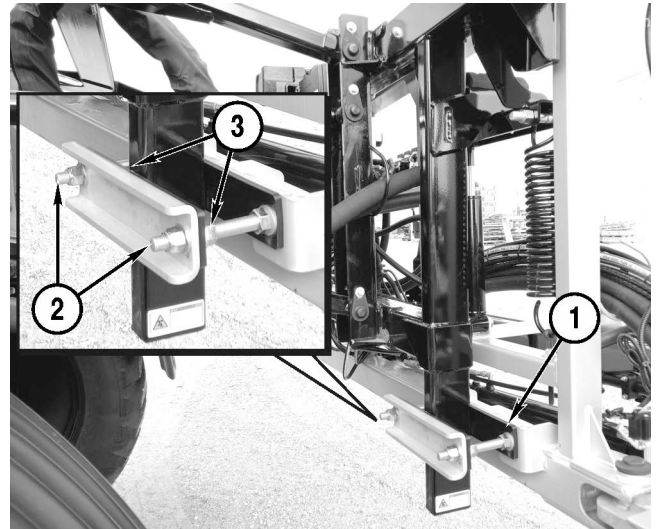

As Required

The following services will be required at various intervals depending on Apache Sprayer use and environmental conditions. Repeat these services as prescribed by the Apache Sprayer Service Interval Chart. See “Apache Sprayer Service Interval Chart” on page 5-5.

- Adjust Boom. See “Adjust Boom” on page 5-7.
- Check Axle Extension Bolt Torque. See “Torque Axle Extension Brace Bolts” on page 5-24.
- Adjust Toe-In. See “Measure and Adjust Toe-In (Standard 120” Axles)” on page 5-38.
- Clean the Primary Engine Air Filter. See “Clean or Change Engine Primary Air Filter” on page 5-25.
- Change Engine Safety Air Filter. See “Change Engine Safety Air Filter” on page 5-41.

NOTICE: When operating in severe conditions, the primary air filter should be cleaned after every 40 hours of use

- Flush Wet System. See “Flushing Booms” on page 4-27.

Daily

The following services must be performed daily, before operation of the Apache Sprayer.

NOTICE: NEVER clean the inner engine air filter (engine safety air filter). When it is dirty, ALWAYS replace it with a new one.

Grease Boom

(Optional Equipment)

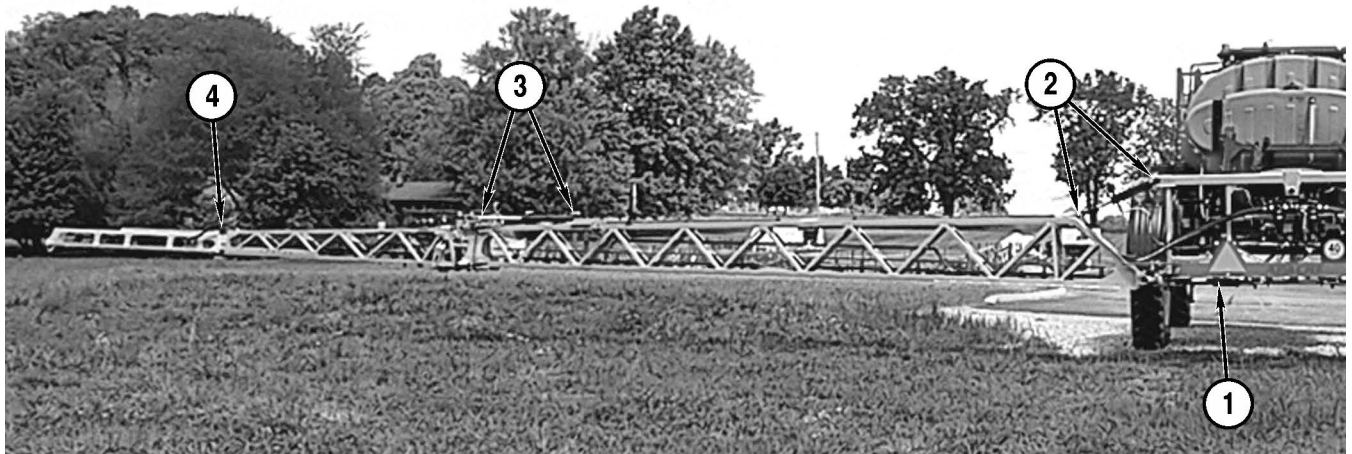

Both aluminum and steel booms are equipped with four sets of grease fittings. Apply an ample amount of lithium grease through each of the grease fittings.

- | | |
|---|---|
| <ol style="list-style-type: none"> 1. Boom Fold Cylinder <ul style="list-style-type: none"> • 2 fittings 2. Tilt Cylinder <ul style="list-style-type: none"> • 2 fittings | <ol style="list-style-type: none"> 3. Boom Tip Fold <ul style="list-style-type: none"> • 7 fittings [aluminum] • 8 fittings [steel] 4. Boom Breakaway <ul style="list-style-type: none"> • 1 fitting |
|---|---|

Boom Fold Cylinder

There are two grease fittings (1) on each boom fold cylinder. The left side is shown.

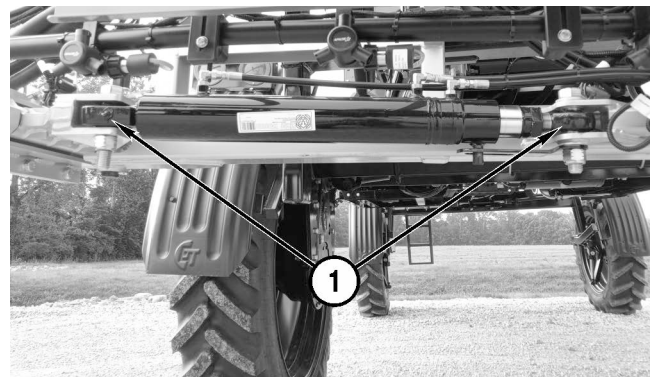

Tilt Cylinder

There are two grease fittings (1) on each tilt cylinder. The left side is shown.

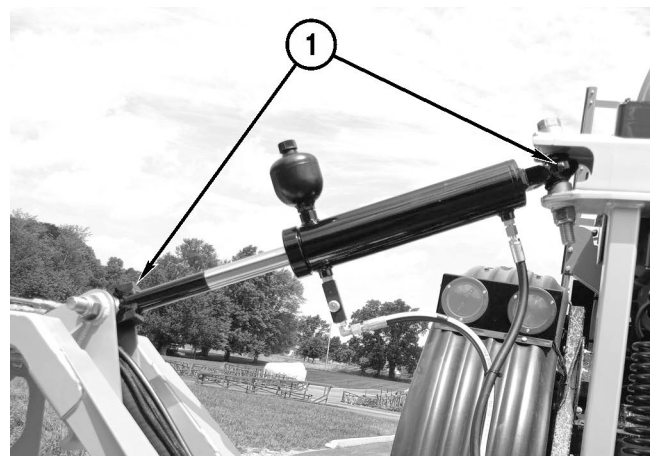

Boom Tip Fold

There are seven aluminum grease fittings (upper image) or eight steel grease fittings (lower image) in the boom tip fold area of each boom. The left side is shown.

NOTE: The booms must be placed in the open position to access some fittings and in the folded position to access the remaining fittings.

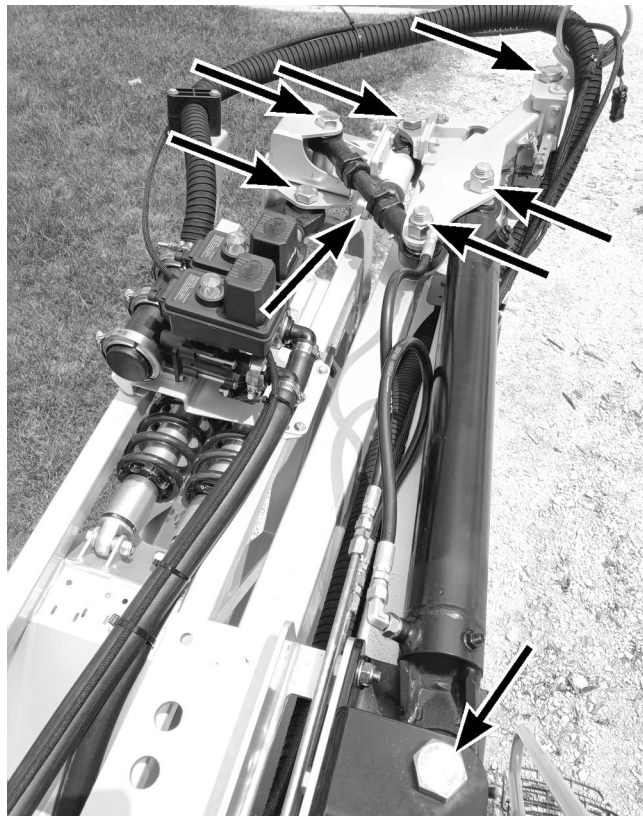

Boom Breakaway

There is one grease fitting (1) on each boom breakaway. The left side is shown.

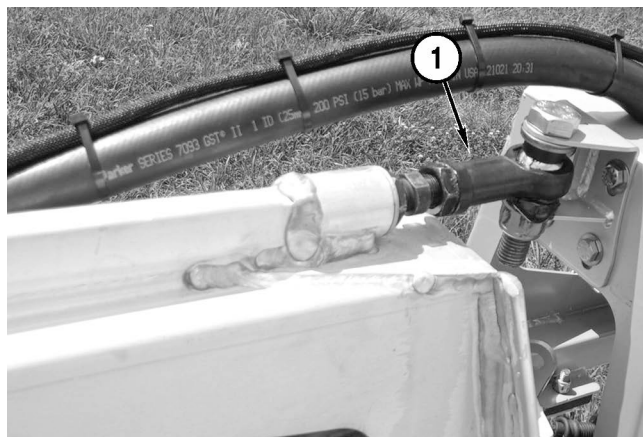

Flush Wet System

Drain and flush the product tank and wet system after use and when changing chemicals. See “Flushing Product Tank” on page 4-25. See “Flushing Booms” on page 4-27.

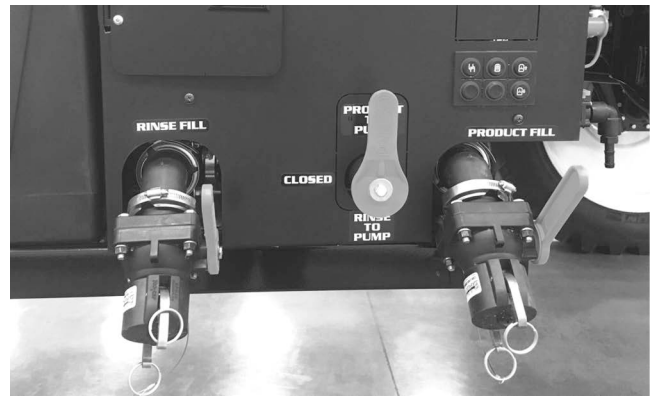

Check Tire Pressure

Perform the following:

- Check the tires for damage. Replace tires that have cuts or bubbles.
- Check the tires for proper inflation pressure. Inflate tires according to the tire manufacturer’s recommendations. See “Apache AS850 Fluids, Filters and Capacities” on page 1-2.
- Check the rims for cracks and other damage. Replace damaged rims.



Check Engine Oil Level

NOTICE: If the engine has been running, shut off and wait 10 minutes before checking oil level.

The dipstick is located in the engine compartment, on the left side of the engine.

While parked on level ground, remove the dipstick (1) and check the oil level.

The oil level should be within the hatched area on the dipstick.

If the oil level is below the ADD mark, add high quality Lucas 15W-40 Magnum motor oil at the oil fill location (2) on top of the engine, just after the radiator expansion tank.

Add oil as needed to bring the level to the hatched area on the dipstick.

Replace the dipstick.

An auxiliary oil fill location (3) is next to the dipstick on some machines.

Additional lubricating oil system information is available in the engine manufacturer’s manual provided with the Apache Sprayer.

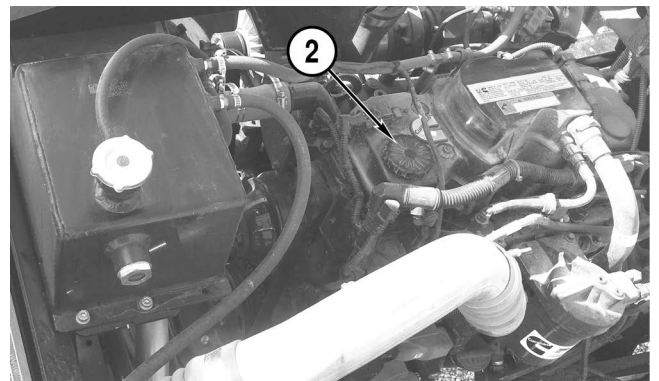
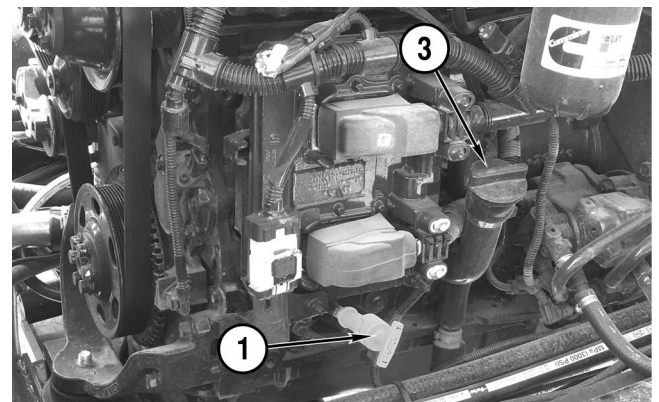

Check Cooling System



WARNING! Fire Hazard. Coolant may be flammable under certain conditions. NEVER allow coolant to come into contact with hot surfaces.



WARNING! Exposure Hazard. Wear eye protection and rubber gloves when handling engine coolant. Avoid skin contact with coolant. If contact with the eyes or skin should occur, flush eyes and wash immediately with clean water.



WARNING! Burn Hazard. NEVER remove the radiator cap if the engine is hot. Steam and hot engine coolant will spray out and seriously burn you. Allow the engine to cool down before you attempt to remove the cap.

Remove the radiator cap and check the coolant level. Remove the radiator cap slowly to relieve internal pressure. The coolant should be level with the bottom of the fill neck.

Add coolant as necessary. DO NOT overfill the cooling system, as this may cause the coolant to spray from the system during operation.

NOTICE: See the engine manufacturer's manual for coolant requirements and additional cooling system information. Coolant specifications must meet or exceed ASTM D3306 / D6210 or RP-329.

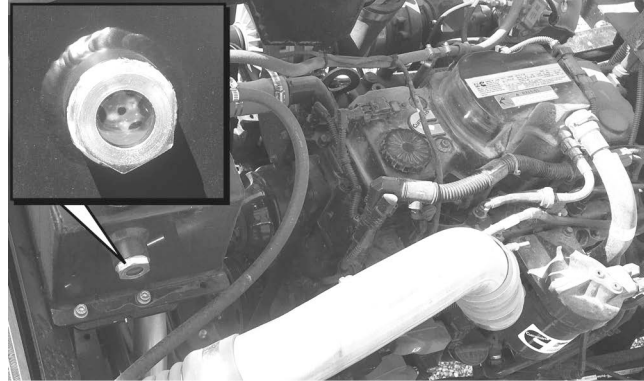

Install the radiator cap.



WARNING! Burn Hazard.

ALWAYS tighten the radiator cap securely after checking the coolant. Steam can spray out during engine operation if the cap is loose.

Inspect the cooling system components for damage and debris.

- Check tubes, hoses and other components for damage and leaks.
- Replace damaged components as necessary.
- Clean debris from around or between cooling package components.

Cycle Fan Reverser

Operate this function until the radiator and coolers are free of dust and debris. See "Diagnostics Page 3: Fan Control" on page 3-10.

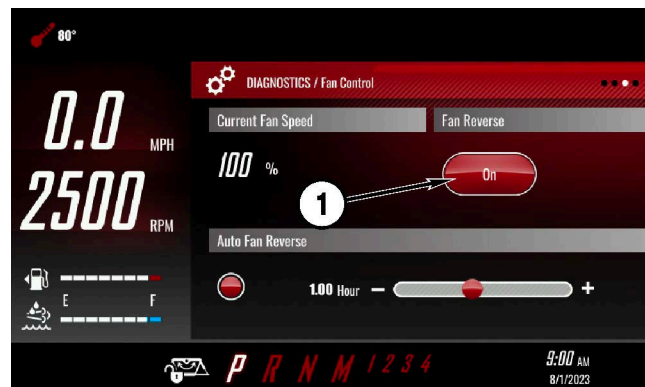

Check Transmission Oil Level

The transmission oil dipstick is located in the engine compartment, on the left side of the engine, and toward the cab.

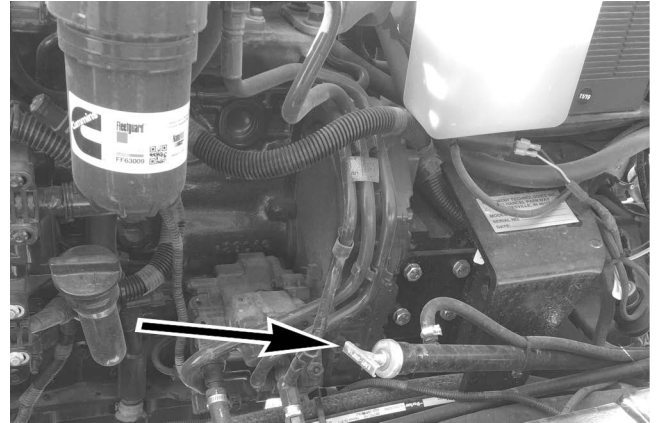

NOTE: All measurements must be taken with the engine running at low idle.

The transmission oil level check must be carried out as follows:

- Check transmission oil level weekly
- Machine on level ground
- Transmission in Neutral position
- In the cold start phase, the engine must be running approximately 2 to 3 minutes at idle speed. The transmission oil level must be above the cold start mark “COLD MIN”.

Turn the dipstick handle counterclockwise to loosen.

Remove the dipstick and check the transmission oil level.

NOTICE: *DO NOT overfill the transmission oil. Overfilling can damage the transmission or cause the transmission to malfunction or overheat.*

NOTICE: *Use only Lucas 15W-40 Magnum motor oil.*

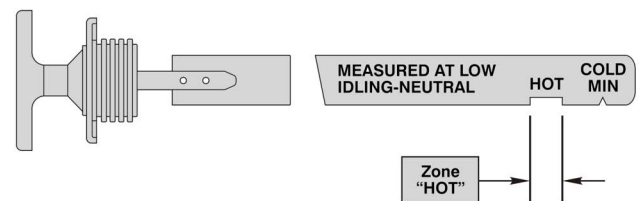

Check Hydraulic Fluid Level

NOTICE: *The machine must be on level ground with the booms folded and in the transport position for an accurate hydraulic fluid level reading.*

The hydraulic fluid reservoir is located on the right side of the Apache Sprayer and a sight glass (1) indicates the hydraulic fluid level and temperature.

NOTICE: *Use only Lucas Universal Hydraulic Fluid, or equivalent, for the Apache Sprayer hydraulic system.*

If no fluid is visible in the sight glass, remove the tread plate above the hydraulic tank to access the fill cap. Then remove the fill cap (2) and add Lucas Universal Hydraulic Fluid, or equivalent, until fluid is visible in the bottom of the sight glass.

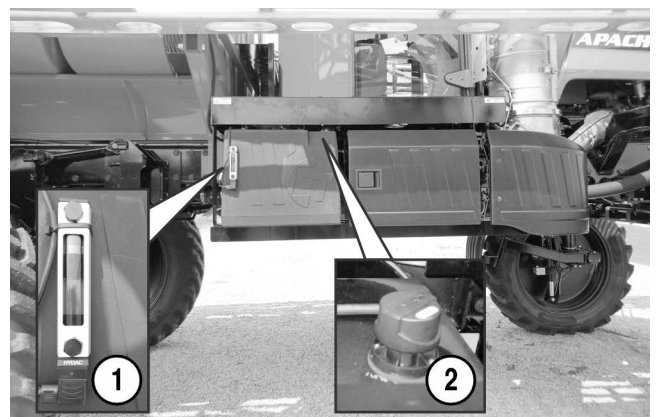

NOTICE: *Oil should be topped off after the oil in reservoir is at operating temperature to avoid overfill. DO NOT fill more than 3/4 up on the sight glass.*

Re-Phase Steering Cylinders

With the engine operating at 1000 rpm and the hydraulic fluid at operating temperature, turn the steering wheel to the extreme left and continue to turn the wheel 100 revolutions. Repeat this process turning the steering wheel to the extreme right. The vehicle must be moving in a forward direction while re-phasing the steering.

Drain Primary Fuel Filter

Drain the water from the primary fuel filter by opening the valve (1).

Close the valve after draining.

Use the priming pump (2) to prime the filter.

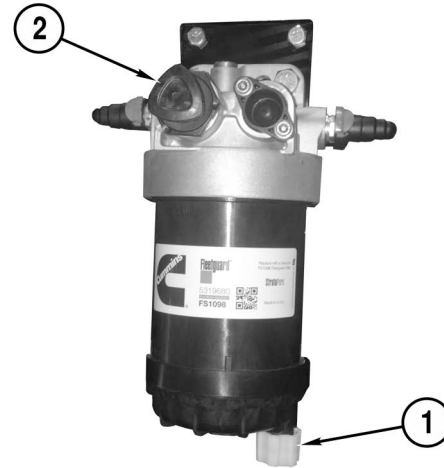

Every 40 Hours

The following services must be performed after every 40 hours of operation of the Apache Sprayer.

Adjust Poly Tank Straps

Check the poly tank straps while the tank is at least 50% full. If the straps feel or appear loose, tighten them evenly from side to side without deforming the tank, the bolts or the tank cradle.

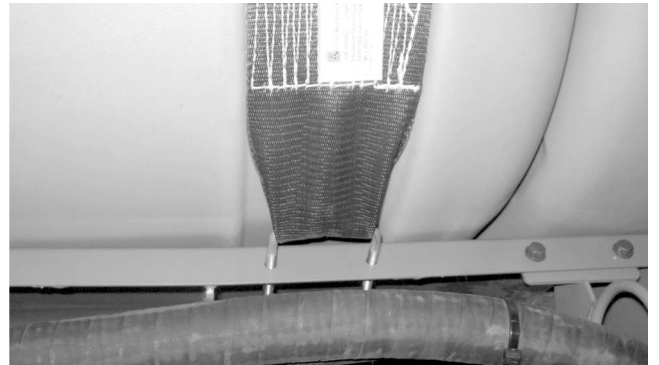

Torque Lug Nuts

Torque wheel lug nuts to:

- 420 lb-ft [569 N•m]



Grease Rear Suspension

Apply Lucas lithium grease or equivalent to the upper (1) and lower (2) grease fittings at each end of the suspension cylinders.

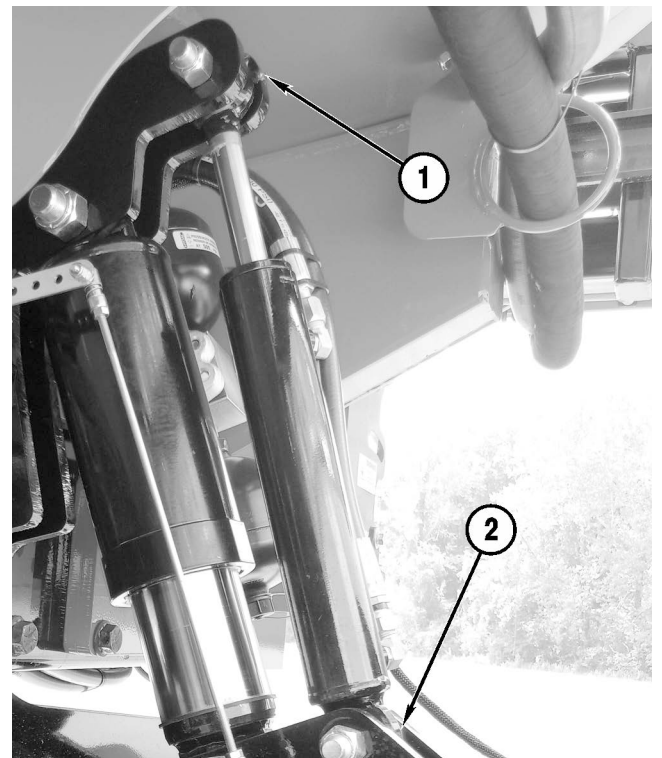

NOTE: A block can be used between the frame rail and rear axle to relieve load from the suspension cylinder ball joints. By disconnecting the suspension switch ball joint, the suspension can be manually lowered onto the block between the axle and frame. This will allow the ball joints to take an adequate amount of grease.

Grease Front Axle Assembly

Each side of front axle has two king-pin grease fittings (1), one hub grease fitting (2), and one inter-flex bearing grease fitting (3). The right wheel is shown.

Apply lithium grease through the two king-pin grease fittings (1).

Apply lithium grease through the hub bearing grease fitting (2).

Apply lithium grease through the inter-flex bearing grease fitting (3).

NOTE: The inter-flex bearing are sealed chambers and once greased require very little grease to maintain.

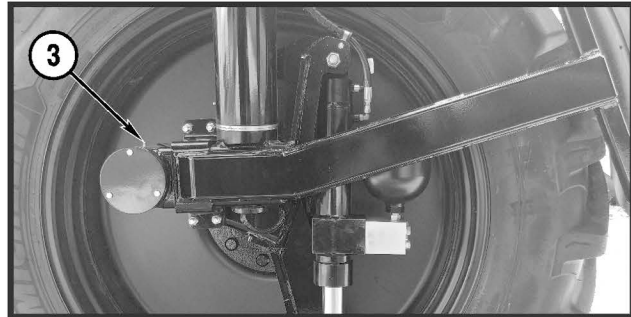
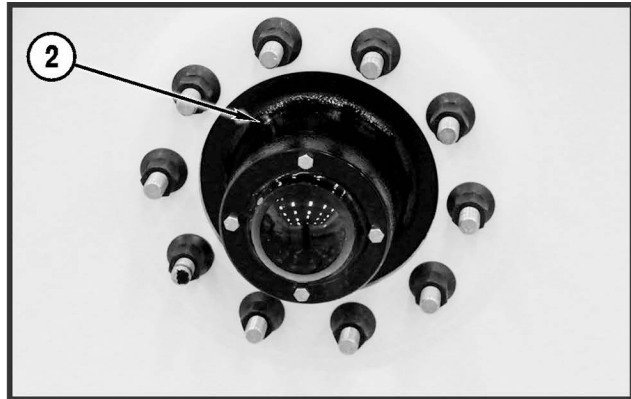
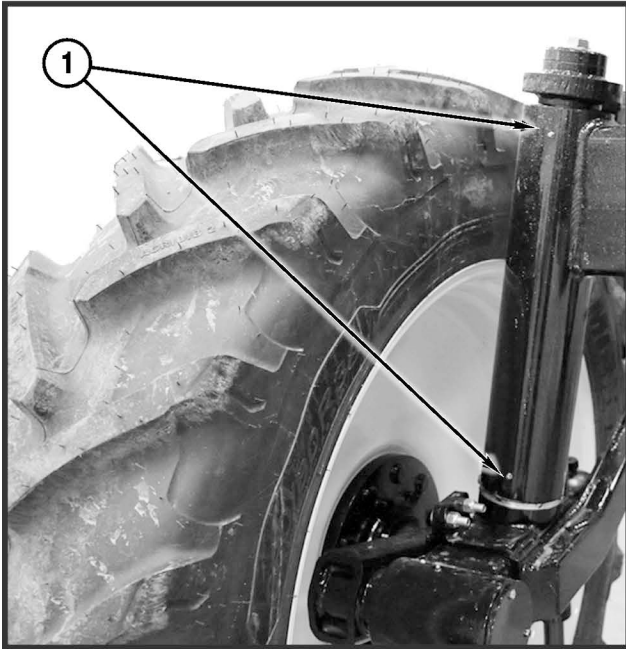

Apply Lucas lithium grease or equivalent through each grease fitting.

Repeat these steps for the other front wheel.

Grease Axle Components (adjustable only)

The rear axle is equipped with 24 grease fittings, installed in two square-tube axle extension assemblies. Eight fittings point downward from the bottom faces of each square tube. Shown are the four rear-most fittings (1).

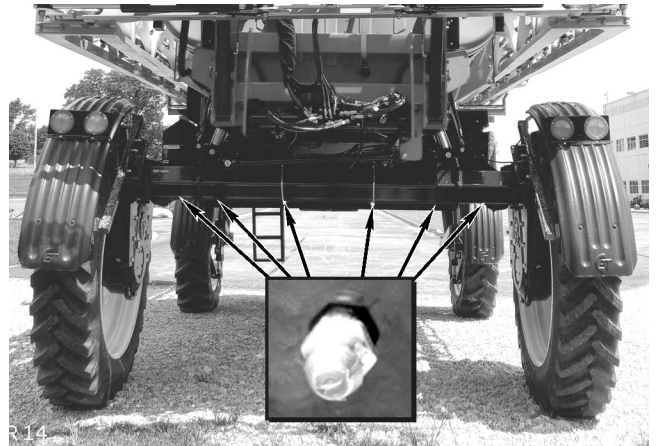

The front axle is equipped with 12 grease fittings.

Apply an ample amount of Lucas lithium grease or equivalent through each of the fittings.

An axle pivot is located under the vehicle on the front axle. The pivot is equipped with a grease fitting on front (1) and rear (2) of the front axle.

Apply an ample amount of Lucas lithium grease or equivalent through each of the fittings.

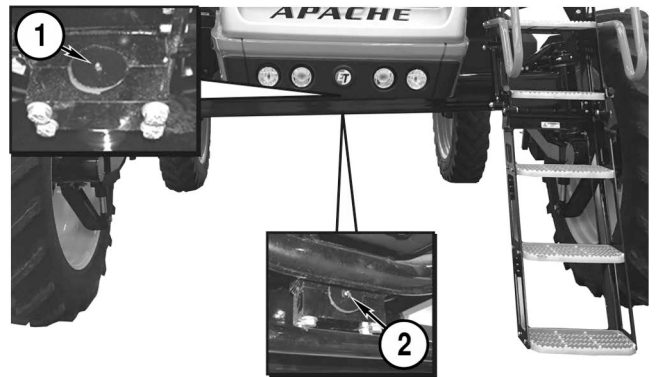

Grease Rod End - Fixed Axle

The fixed axle has a grease fitting on each rod end near the steering arm.

Apply an ample amount of Lucas lithium grease, or equivalent, through each of the fittings.

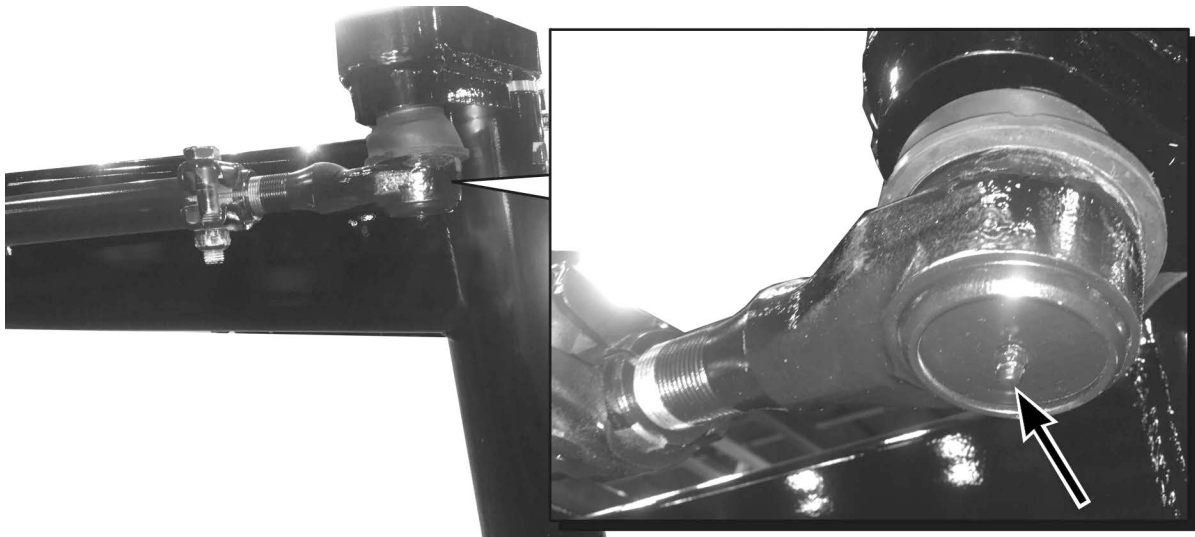

Check Differential Fluid Level

The differential is located under the Apache Sprayer, on the rear axle. The fill/level plug is directly above the drain plug on the rear of the differential.

With the machine parked on level ground, remove the differential fill/level plug (1) and check the fluid level. The fluid should be level with the bottom of the fill/level hole.

Install the plug and tighten.



Check Differential for Leaks

Inspect the differential for leaks at the U-joint, near the drop boxes, and between inner and outer housings. Repair the leaks before operating the Apache Sprayer.

Check Final Drive Fluid Level

Depending on the machine's crop clearance, the Apache Sprayer is equipped with either a drop box or planetary final drive.

Drop Box

The drop box level plug (1) is located on the drop box at each rear wheel. The left drop box is shown.

Remove the drop box level plug (1). The fluid level should be at the bottom of the level hole. If the fluid level is good, install and tighten the level plug (1).

NOTICE: Use only Lucas 80/90 Gear Oil or equivalent for the drop box fluid.

If the fluid level is low, remove the drop box fill plug (2) and add fluid until it is level with the bottom of the level hole (1).

NOTE: Drop Box Fluid Capacity: Approximately 21 quarts [20 liters]

Install and tighten the fill plug (2) and the level plug (1).

Repeat the steps for the other drop box.

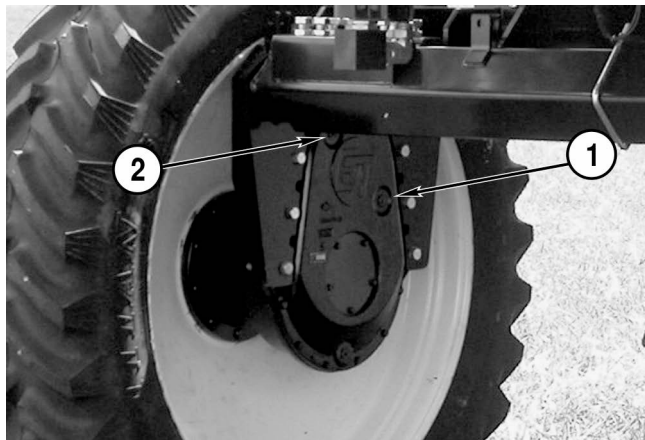

Check Drop Box for Leaks

Inspect the drop box for leaks around the housing and around the three plugs.

Planetary

The planetaries are located on each rear wheel. The plug (1) on the planetary serves as the drain, level, and fill location.

To check the level of the planetary fluid, position the wheel so the plug on the planetary is in the 3 o'clock position.

Remove the plug in the planetary and observe if the fluid is at the bottom of the fill hole. If the level is good, then install and tighten the plug (1).

NOTICE: Use only Lucas 80/90 Gear Oil or equivalent to the bottom of the fill hole.

If level is low, fill each planetary with Lucas 80/90 Gear Oil or equivalent to the bottom of the fill hole.

NOTE: Planetary Fluid Capacity: Approximately 2.9 quarts [2.7 liters].

Install the plug (1) and tighten.

Check Planetaries for Leaks

Inspect the planetary for leaks around the housing and the plug.

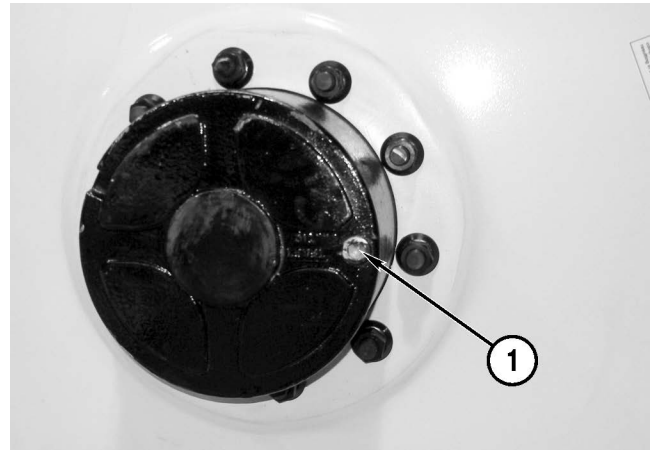

After First 100 Hours

The following services must be performed after the first 100 hours of operation and repeated as prescribed by the Apache Sprayer Service Interval Chart.

- Adjust Poly Tank Straps. See “Adjust Poly Tank Straps” on page 5-17.
- Change Primary Fuel Filter. See “Change Primary Fuel Filter” on page 5-27.
- Change Secondary Fuel Filter. See “Change Secondary Fuel Filter” on page 5-27.
- Change Differential Fluid. See “Change Differential Fluid” on page 5-26.
- Change Transmission Oil and Filter. See “Change Transmission Oil and Filter and Clean Strainer” on page 5-34.

Every 100 Hours

The following services must be performed after every 100 hours of operation of the Apache Sprayer.

Grease Driveline Components

The Apache Sprayer has a total of ten driveline grease fittings. Three of these fittings are slip joint fittings and seven are U-joint fittings.

Apply an ample amount of Lucas lithium grease or equivalent through each of the fittings.

One slip joint grease fitting (1) is located under the Apache Sprayer, between the transmission and the rear axle.

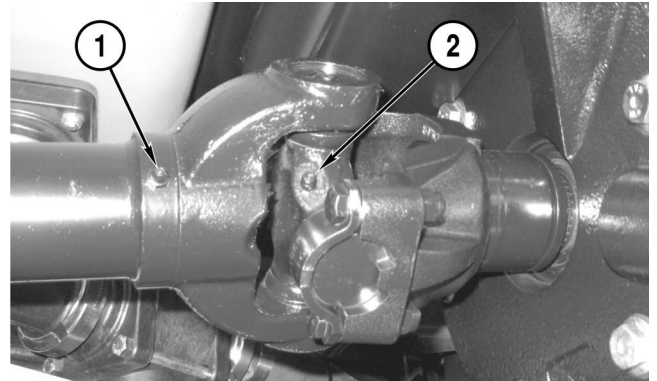

A U-joint fitting is located at the transmission output U-joint (not shown) and another fitting (2) is located on the U-joint connected to the slip joint.

A U-joint fitting (1) is located at the differential input.

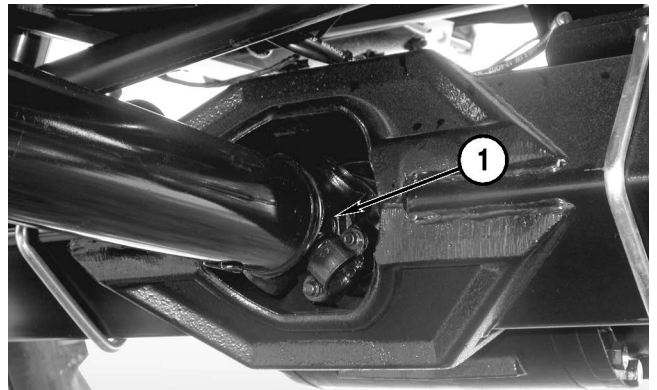

The other two slip joint grease fittings (1) are located under the Apache Sprayer, between the differential and each drop box U-joint, or between the differential and each planetary final drive.

The remaining U-joint fittings (2) are located on the U-joints at each end of the left and right axles.

The left axle is shown.

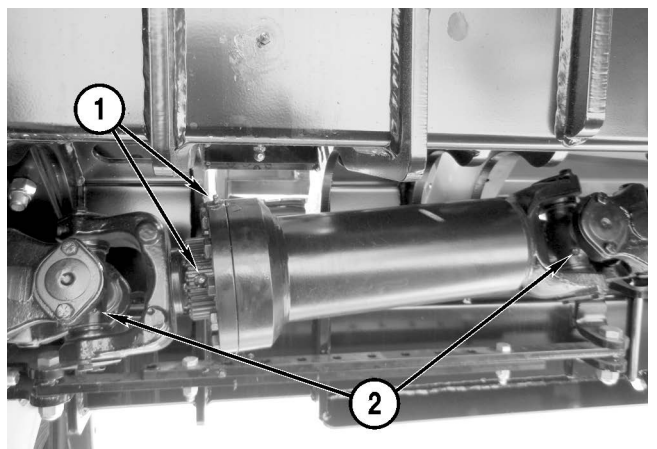

Torque Axle Extension Brace Bolts

NOTICE: There are different axle brace bolt torque values for manual and Adjust-On-The-Go axles. Follow the instructions for your application. Also, it is recommended to thread all bolts down until they make contact with the wedge blocks, verify the slider tube is centered, then tighten in a cross pattern similar to wheel lug nuts.

Manual Adjust Axles

There are six axle brace bolts (1) on each front brace.

Loosen all the jam nuts.

Tighten the axle brace bolts (1) to 80 lb-ft [108 N•m].

Tighten the jam nuts.

Repeat the process for the other front axle brace.

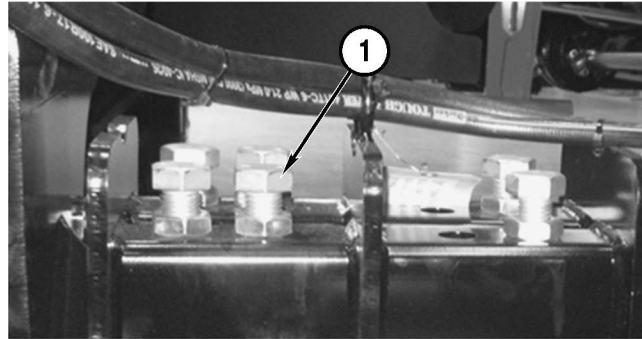

There are twelve axle brace bolts (1) on each rear brace.

Loosen all the jam nuts.

Tighten the bolts (1) to 80 lb-ft [108 N•m].

Tighten the jam nuts.

Repeat the process for the other rear axle brace.

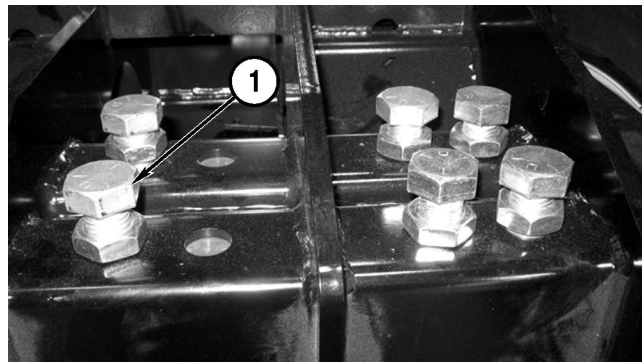

Adjust On The Go Axles

There are six axle brace bolts (1) on each front brace.

Loosen all the jam nuts.

Tighten the axle brace bolts (1) to 22 lb-ft [30 N•m].

Tighten the jam nuts.

Repeat the process for the other front axle brace.



There are twelve axle brace bolts (1) on each rear brace.

Loosen all the jam nuts.

Tighten the bolts (1) to 22 lb-ft [30 N•m].

Tighten the jam nuts.

Repeat the process for the other rear axle brace.

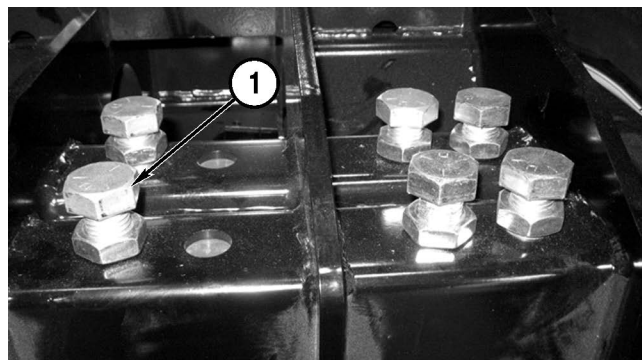

Every 250 Hours or Yearly

NOTE: Some services at this interval were performed at the “After First 100 Hours” interval. If the service was performed as prescribed, measurement of 250 hours should begin at the 100 hour mark.

The following services must be performed after every 250 hours of operation or yearly.

Clean or Change Engine Primary Air Filter

NOTICE: When operating in severe conditions, the primary air filter should be cleaned if indicated by the console display.

NOTICE: If a “Change Air Filter” fault is indicated on the touch screen display, stop immediately and remove and clean or replace the primary air filter as needed.

The primary air filter is mounted in the engine compartment, above the engine and toward the cab.

Clean the outside of the air cleaner assembly.

Lift up the plastic latch (1) and rotate the round end of the housing to the unlock position (2).

Pull off the end (3).

NOTICE: NEVER clean the inner engine air filter (engine safety air filter). When it is dirty, ALWAYS replace it with a new one.



Pull filter and slide out of housing.

Clean the filter using compressed air. Blow the filter from the inside-out.

If installing a new primary engine air filter:

- Primary Engine Air Filter Part Number: 230512001.

Install the filter by sliding it over the safety air filter.

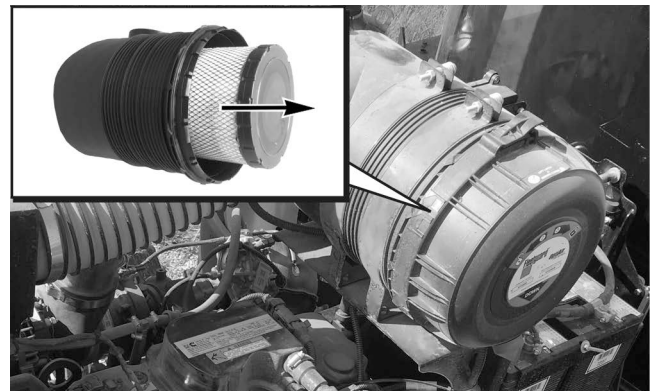

Reinstall the housing end cap by sliding it onto the housing with the drain (1) oriented downward and twisting clockwise to the lock position.

NOTE: The drain should be at the 6:00 position after installation. If not, remove the end cap, clock it properly, and reinstall.



Change Differential Fluid

The differential is located under the Apache Sprayer, on the rear axle. The fill/level plug (1) is directly above the drain plug on the rear of the differential.

Remove the differential drain plug and drain the fluid into a suitable container. Dispose of the fluid properly.

Install the drain plug and tighten.

NOTICE: Use only Lucas Universal Hydraulic Fluid, or equivalent, for the differential fluid.

Remove the differential fill/level plug (1). Add fluid until it is level with the bottom of the fill/level hole.

- Differential Fluid Capacity:
Approximately 11.9 quarts [11.26 liters].

Install the fill/level plug (1) and tighten.



Change Hydraulic Fluid Filter

The hydraulic fluid filter is located on the right side out-rigger under the service platform.

Remove the six bolts and lift off the service platform (1).

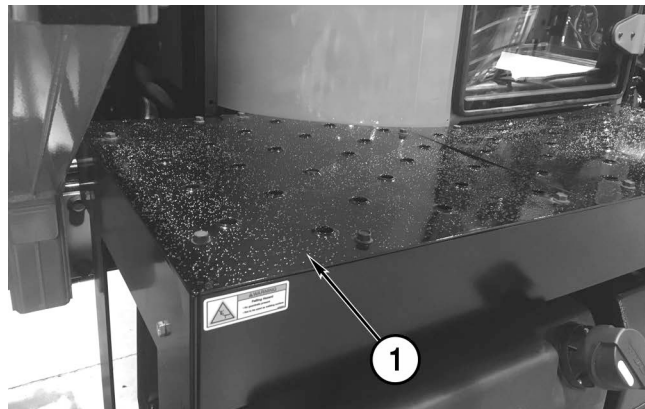

Remove the cover (1) from the filter housing.

Remove the filter from the assembly.

Discard the filter into an appropriate container.

Install an o-ring on the filter housing and lubricate it with clean Lucas Universal Hydraulic Fluid or equivalent.

Install the filter into the filter housing.

Install and tighten the filter housing cover.

Use the sight glass to check the fluid level. See "Check Hydraulic Fluid Level" on page 5-15.

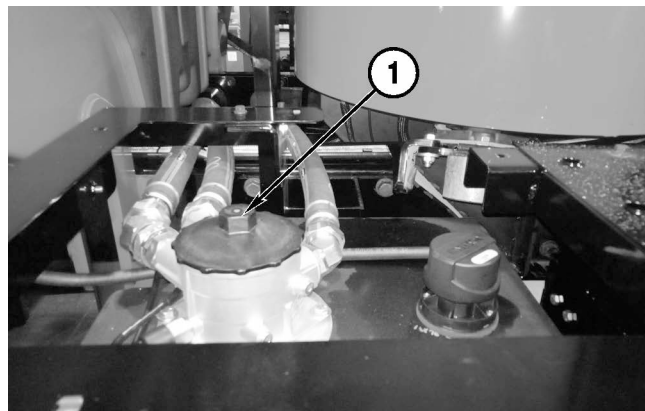

Every 500 Hours or Yearly

NOTE: Some services at this interval were performed at the “After First 100 Hours” interval. If the service was performed as prescribed, measurement of 500 hours should begin at the 100 hour mark.

The following services must be performed after every 500 hours of operation or yearly.

Change Primary Fuel Filter

The primary fuel filter is located under the walking surface after the boom support.



WARNING! Fire Hazard. Wipe up fuel spills immediately. Fuel will spill from the filter and fuel lines when loosened or removed. Use a suitable container to collect the fuel and dispose of properly.

Turn the filter counterclockwise to remove. Dispose of the filter properly.

NOTICE: *ALWAYS* replace the fuel filter with a new fuel filter.

- Primary Fuel Filter Part Number: 261000003

Fill the new filter with diesel fuel before installing.

Tighten the filter, by hand, 3/4 to 1-1/4 turns after the seal contacts the filter housing.

NOTE: It is not necessary to bleed the fuel system after replacing fuel filters.

Additional fuel system information is available in the engine manufacturer’s manual provided with the Apache Sprayer.

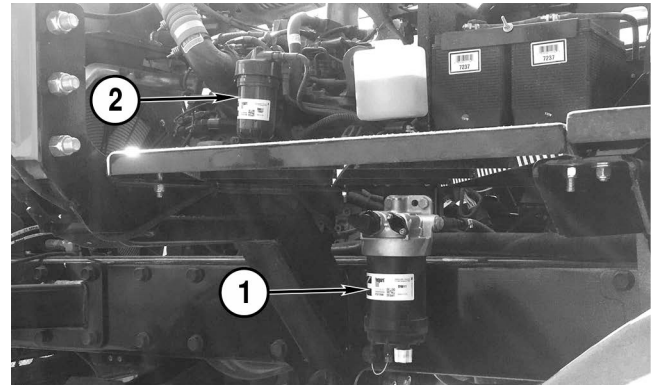

Change Secondary Fuel Filter

The secondary fuel filter (2) is located in the engine compartment on the left side of the engine.

Turn the filter counterclockwise to remove.

Dispose of the filter properly.

NOTICE: *ALWAYS* replace the secondary fuel filter with a new secondary filter.

- Secondary Fuel Filter Part Number: 211000000.

Fill the new filter with diesel fuel before installing.

NOTICE: *DO NOT* over-tighten the filter. Damage to the seal can result.

Tighten the filter, by hand, 3/4 to 1-1/4 turns after the seal contacts the filter housing.

NOTE: It is not necessary to bleed the fuel system after replacing fuel filters.

Additional fuel system information is available in the engine manufacturer’s manual provided with the Apache Sprayer.

Inspect Front Accumulator and Suspension Cylinder

Inspect the front accumulators and suspension cylinders for hydraulic leaks and correct operation. Typically, the cylinder should have 4 to 6 in. [101.6 to 152.4 mm] of the cylinder ram showing while the Apache Sprayer is on level ground.

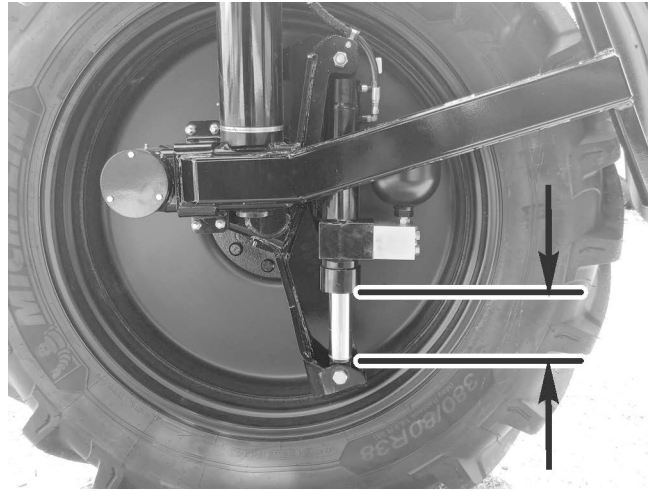

Check Accumulator Charge

Safely raise the front of the Apache Sprayer so the front tires are just off of the ground.

Remove the cap (1) and install a nitrogen valve and gauge on the accumulator.

Open the valve and check the nitrogen pressure.

- AS850 Accumulator Nitrogen Pressure:
450 psi [31 bar]

Add pressure to the accumulator baseline as follows:

- +50 PSI [3.45 bar] for an Adjustable Axle

NOTE: It may be necessary to top off the nitrogen level yearly.

NOTICE: *If oil comes out of the accumulator charge port, the accumulator has failed. Contact your dealer for a replacement accumulator.*

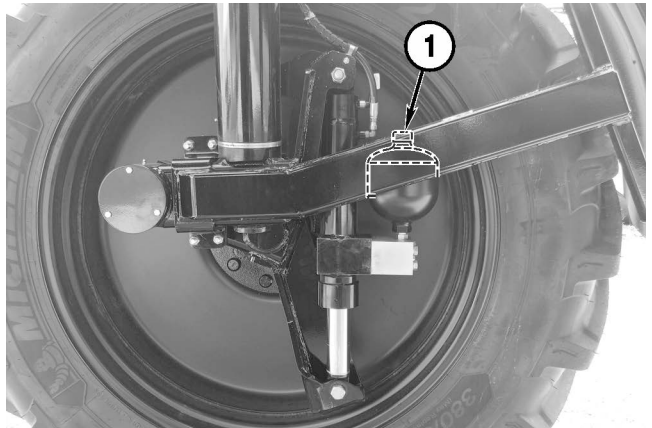

Check Rear Suspension Cylinder, Accumulator and Charge

A special low profile kit was developed to ease the measurement and charging of the rear suspension accumulators on 2011 and newer Apache Sprayers. The low profile kit also requires the use of the accumulator charging kit and an adapter.

If a low profile adapter is not available, the accumulator pressure can be checked by removing the accumulator from the manifold.

- Low Profile Kit: 98000064
- Accumulator Charging Kit: 980000419
- Adapter: 980000421



Remove the allen-head bolt from adapter, Part Number 980000421, and leave the o-ring in place.

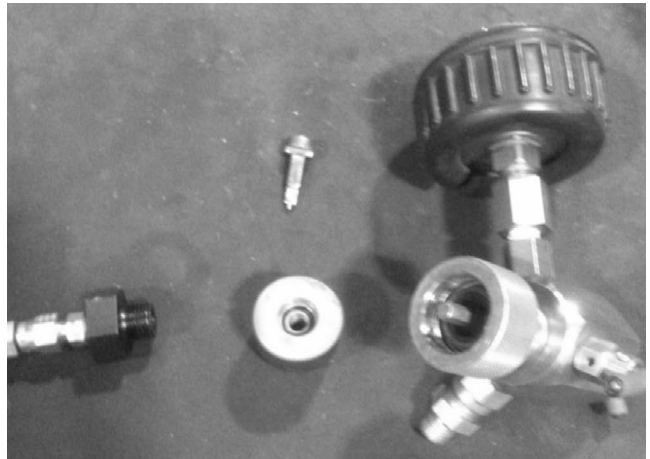

Assemble the adapter, Part Number 980000421 and the charging kit tool, Part Number 980000419.



For safety and better access to the bottom accumulator, place blocks between the frame and axle and lower the rear suspension onto the blocks. Be careful to not pinch the suspension switch wire.

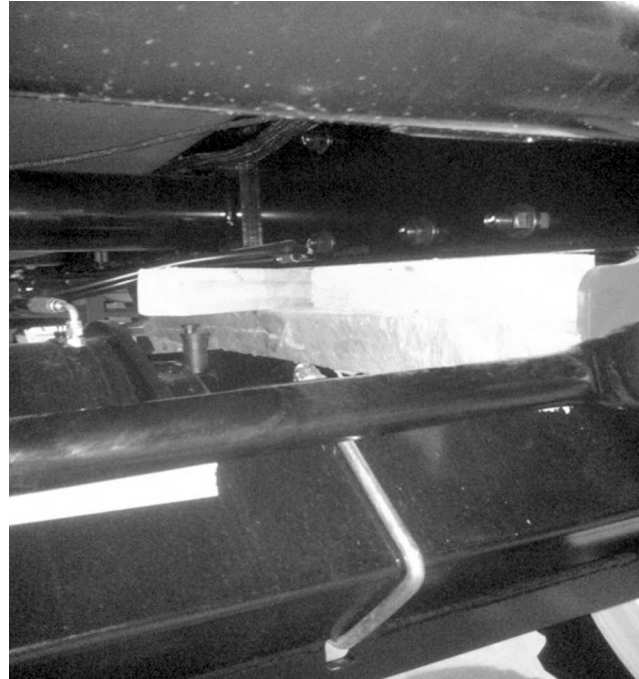

Remove the plastic cap from the accumulator and loosen the allen bolt. Only loosen the bolt enough for the pressure to be checked.



Install the low profile adapter onto the accumulator.

Use a 1/4" wrench to turn the hex to open the accumulator valve.



Check the accumulator nitrogen pressure.

Rear Ram Cylinder Accumulator Nitrogen Pressure:

- 500 psi [34.5 bar]

NOTE: It may be necessary to top off the nitrogen level yearly.

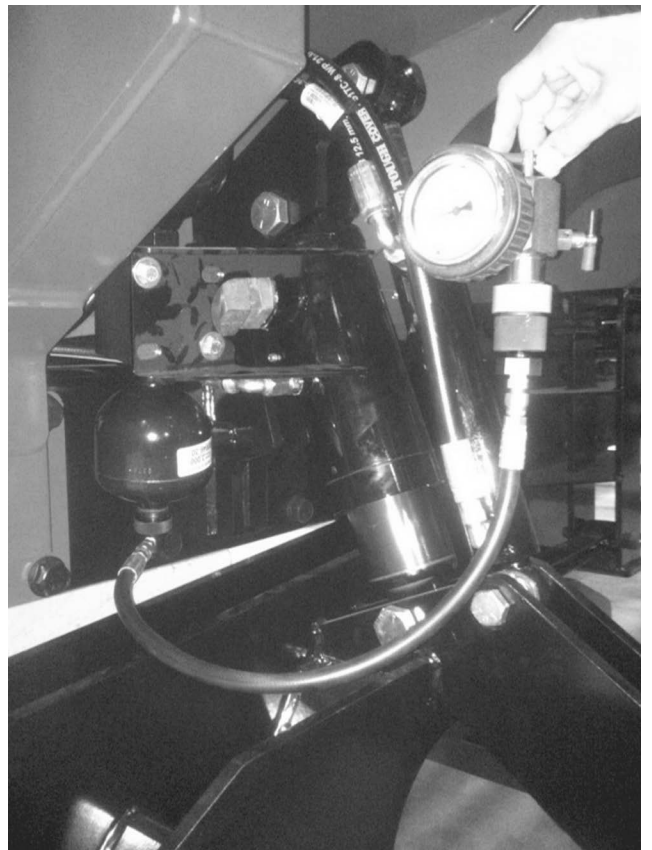

Check the accumulator nitrogen pressure on the rear preload suspension manifold located on the back of the frame.

Preload Accumulator Pressure:

- 550 psi [38 bar]

NOTE: It may be necessary to top off the nitrogen level yearly.



Change Engine Oil and Filter



WARNING! Burn Hazard. If you must drain the engine oil while it is still hot, stay clear of the hot engine oil to avoid being burned. ALWAYS wear eye protection.

Operate the engine for approximately five minutes to warm the engine oil. Shut off the engine.

The engine oil drain plug is located on the bottom of the oil pan. Remove the engine oil drain plug and drain the oil into a suitable container. Properly dispose of the used engine oil.

Install the drain plug and tighten to the torque value below:

- 1.Plug with Copper Washer: 52 lb-ft [71 N•m]
- 2.Plug with O-ring: 37 lb-ft [50 N•m]

The engine oil filter is located on the right side of the engine.

Turn the engine oil filter counterclockwise to remove. Dispose of the filter properly.

NOTICE: DO NOT over-tighten the filter. Damage to the seal can result.

Lubricate the seal on the engine oil filter.

- Engine Oil Filter Part Number: 201450241.

Install and tighten the filter, by hand, 3/4 to 1-1/4 turns after the seal contacts the filter housing.

NOTICE: DO NOT overfill the engine oil. Crankcase oil capacity can vary. ALWAYS use the dipstick to determine if the engine oil is to the appropriate level.

Fill the engine with high quality Lucas 15W-40 Magnum motor oil or equivalent at the oil fill location (2) on the topside of the engine just behind the radiator reservoir.

An auxiliary fill (3) can be found on the left side of the engine on some machines.

- Engine Oil Capacity:
Approximately 16 quarts [15 liters].

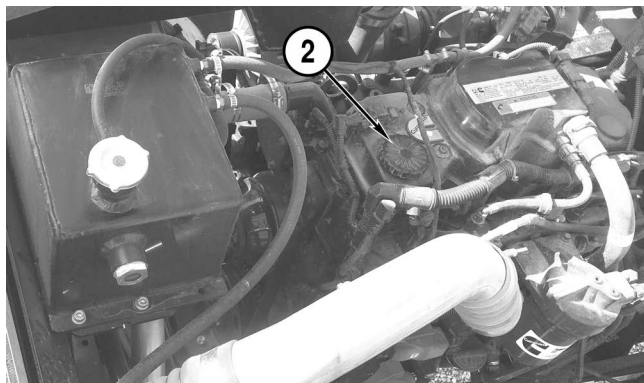
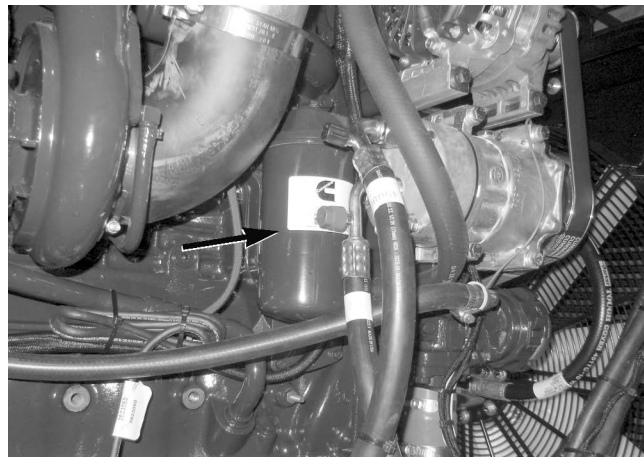
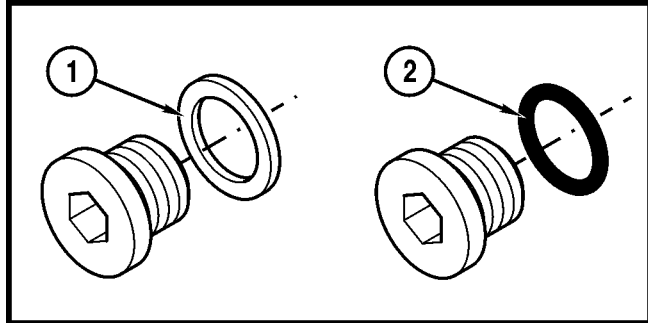

Add oil as needed to bring the level to the hatched area on the dipstick (1).

Install the dipstick.

Operate the engine and check for leaks.

Shut off the engine and wait 10 minutes. Check the engine oil level and add oil as needed to bring the level to the hatched area on the dipstick.

Additional lubricating oil system information is available in the engine manufacturer's manual provided with the Apache Sprayer.

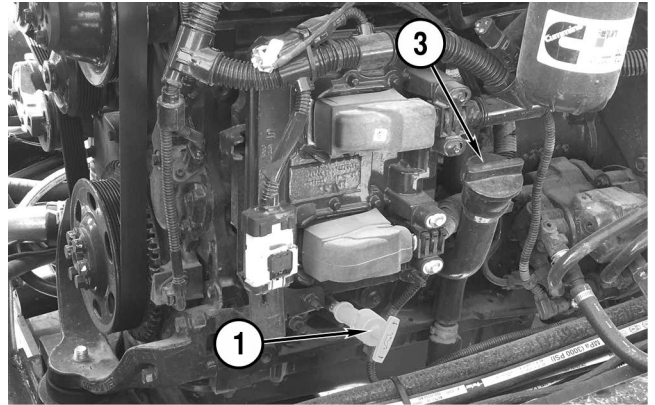

Change Transmission Oil and Filter and Clean Strainer

The transmission drain plug is located under the machine on the front side of the transmission.

Remove the drain plug (1) and drain the transmission fluid into a suitable container. Dispose of the fluid properly.

Install the drain plug (1) Remove the strainer cover plate (2) and clean the strainer with diesel fuel. Replace the strainer if it is damaged in any way.

Install the strainer and cover plate (2).

- Transmission Fluid Strainer
Part Number: 300000095

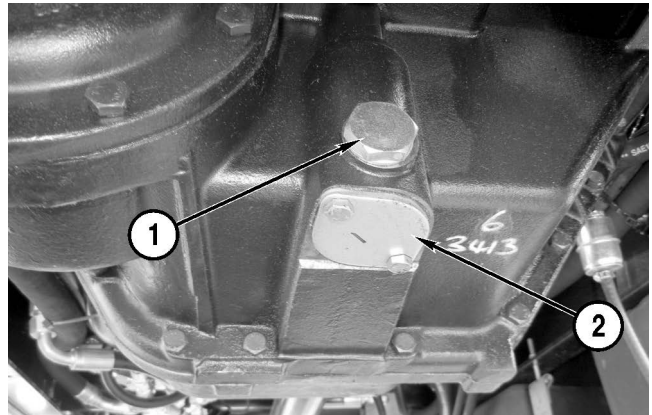

The transmission filter is located on the right side of the transmission, next to the park brake canister.

Turn the filter counterclockwise to remove. Dispose of the filter properly.

NOTICE: DO NOT over-tighten the filter. Damage to the seal can result.

Lubricate the seal on the transmission fluid filter.

Transmission Fluid Filter Part Number: 300000101

Install and tighten the filter, by hand, 3/4 to 1-1/4 turns after the seal contacts the filter housing.

NOTICE: DO NOT overfill the transmission fluid. Overfilling can damage the transmission or cause the transmission to malfunction.

NOTICE: Use only Lucas Universal Hydraulic Fluid or equivalent.



Use a funnel to fill the transmission fluid at the transmission dipstick tube on the left side of the engine.

- Transmission Fluid Capacity: Approximately 16 quarts [15 liters].



Check the transmission fluid level with the transmission fluid at normal operating temperature, transmission in NEUTRAL position, and the engine off.

The fluid level should be between the two dots on the dipstick.

Install the dipstick and turn the handle clockwise to tighten.

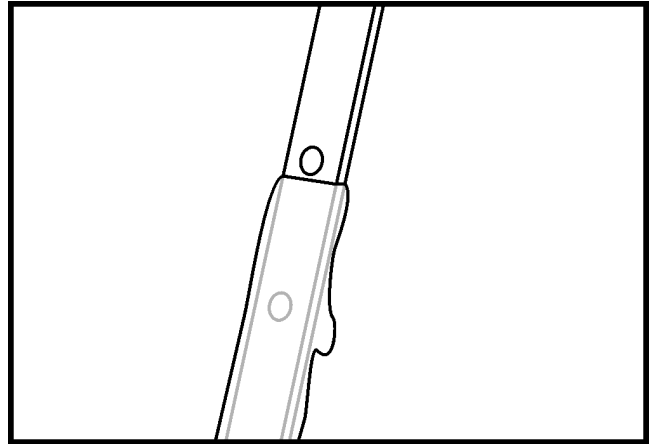

Inspect and Repack Wheel and Inter-Flex Bearings

Contact your dealer to inspect and repack the wheel (1) and inter-flex (2) bearings.

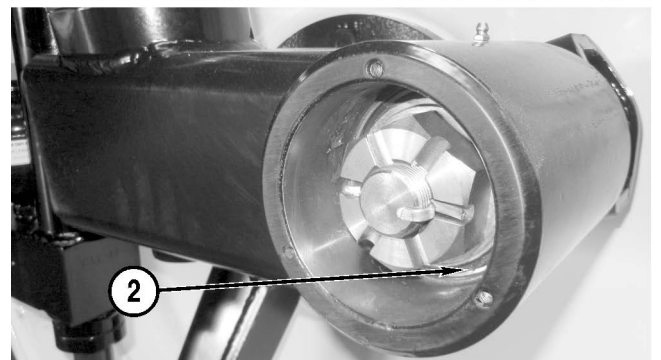
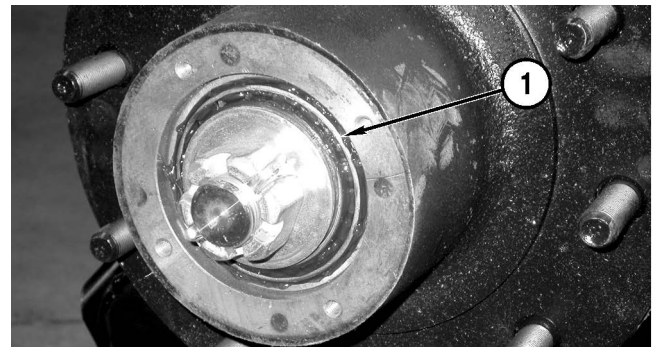

Change Final Drive Fluid

Depending on the machine's crop clearance, the Apache Sprayer is equipped with either a drop box or planetary final drive.

Drop Box

The drop box drain, level and fill plugs are located on the drop box at each rear wheel. The left drop box is shown.

Remove the drain plug (1) and drain the fluid into a suitable container. Dispose of the fluid properly.

Install the drain plug (1).

NOTICE: Use only Lucas 80/90 Gear Oil or equivalent for the drop box fluid.

Remove the drop box fill plug (2) and level plug (3).

Add fluid until it is level with the bottom of the level hole (3).

- Drop Box Fluid Capacity:
Approximately 21 quarts [20 liters]

Install and tighten the fill plug (2) and the level plug (3).

Repeat the steps for the other drop box.

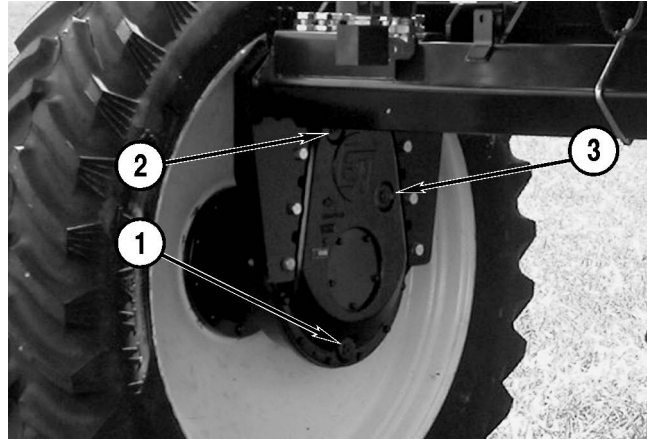

Planetary

The planetaries are located on each rear wheel. The plug (1) on the planetary serves as the drain and fill location.

To drain the planetary fluid, position the wheel so the plug on the planetary is in the 6 o'clock position.

Remove the plug in the planetary, drain the fluid into a suitable container and dispose of the fluid properly.

To fill the planetary fluid, position the wheel so the plug on the planetary is in the 3 o'clock position.

NOTICE: Use only Lucas 80/90 Gear Oil or equivalent for the planetary fluid.

Fill each planetary with Lucas 80/90 Gear Oil or equivalent to the bottom of the fill hole.

- Planetary Fluid Capacity:
Approximately 2.9 quarts [2.7 liters].

Install the plug (1) and tighten.

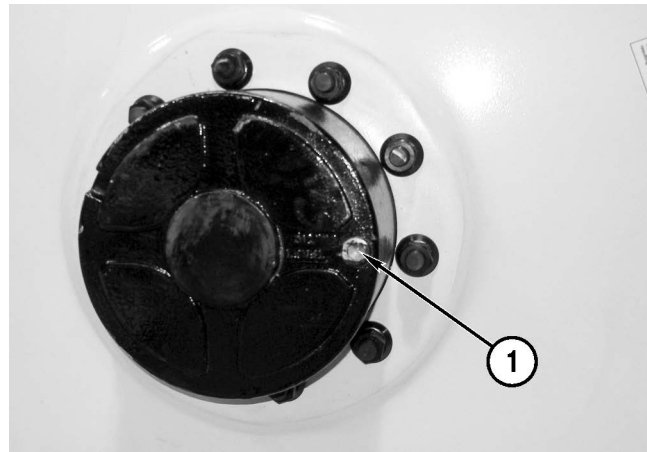

Change Cab Charcoal Filter

NOTICE: DO NOT attempt to clean the old cab air filter. ALWAYS replace with a new filter.

The charcoal air filter is located under the cab, connected to the A/C box.

Remove the knob screw (1) by turning to the left to loosen.

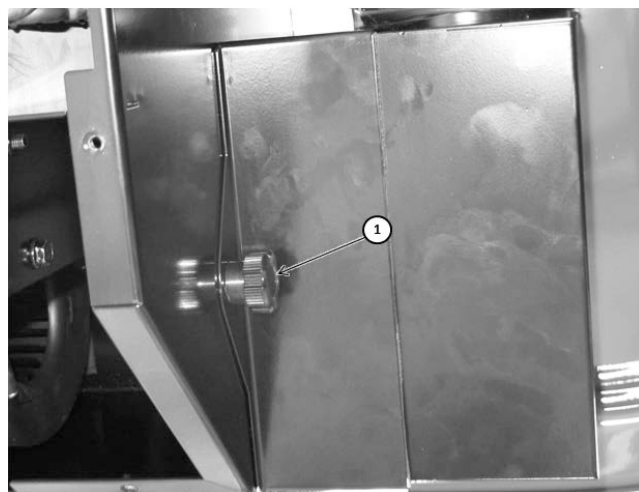

Remove and discard the filter (1) by sliding it out.

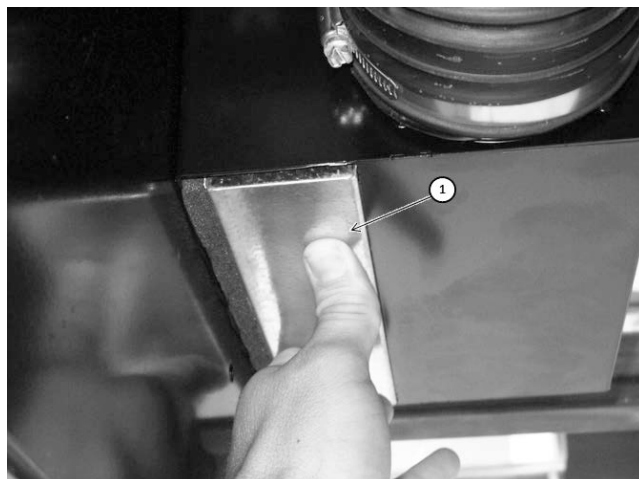

Insert the new filter (1) into the frame with the air-flow arrow pointing toward the A/C box.

- Charcoal Air Filter
Part Number: 490003651

Close the cover and install the knob screw by turning to the right to tighten.



Every Year

The following services must be performed every year.

Measure and Adjust Toe-In (Standard 120" Axles)

Measure Toe-In

Safely lift the front of the Apache Sprayer so the front tires are slightly off of the ground.

Turn the steering wheel so the front wheels are pointing straight.

Make sure the steering cylinder is centered by measuring the lengths of extended rod on each side of the cylinder.

Adjust until lengths (1) are equal.

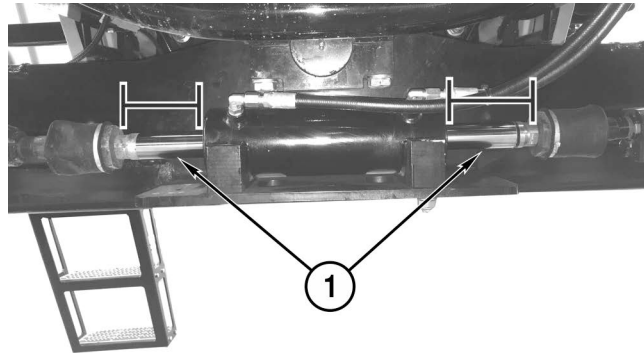

Measure the distance from the center of the spindle (1) on one side to the front (2) and back (3) of the rim on the opposite side, with the measuring point being about half way up the height of the rim.

The distance to the front should be 1/8" [3.2 mm] to 3/16" [4.8 mm] less than the distance to the rear (i.e. toed-in).

If the distance does not fall in the range listed above, adjust the toe-in.

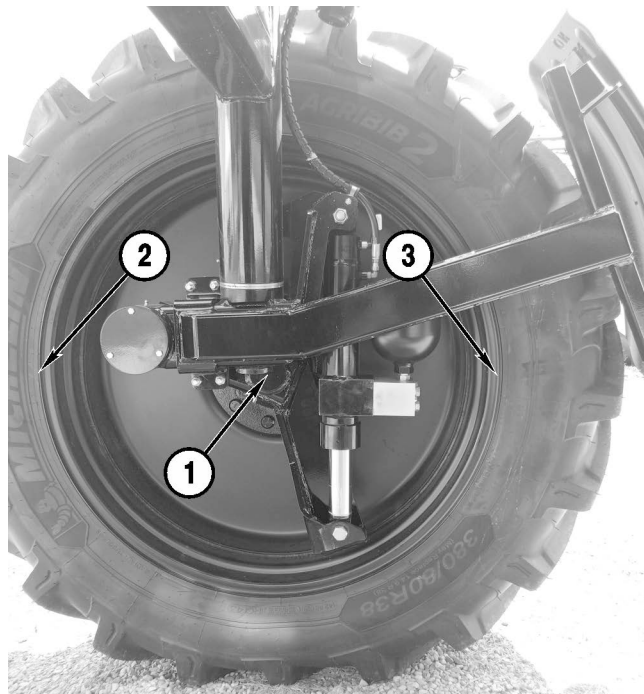
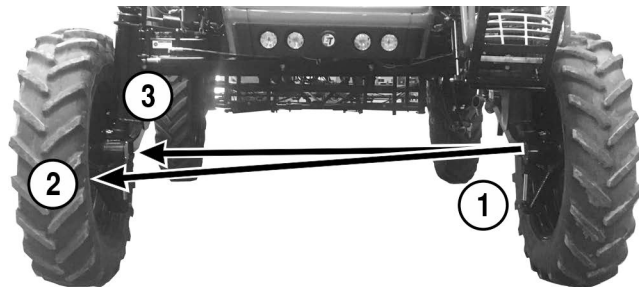

Adjust Toe-in

Loosen the clamps (1) at both ends of the tie rod tube and loosen the tie rod end jam nut (2).

While holding the cylinder rod stationary at the large hex (3), adjust the toe-in by rotating the tube (4).

Perform the toe-in measurement/adjustment procedure from both sides.

After setting the toe-in, tighten the jam nut for the tie rod end. Tighten the bolt for the tie-rod clamp to 92 ft.lb. [125 N-m] of torque.

Safely lower the front end.

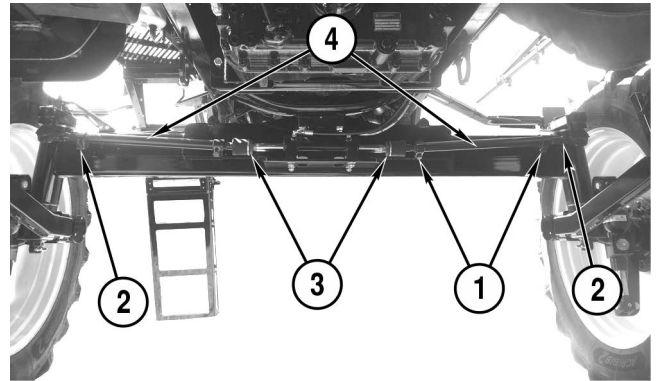

To adjust the steering cylinder rod:

Loosen the nut and bolt on the steering cylinder clamp (1).

Use a wrench on the ball joint end (2) to adjust the spacing.

- If distance between the strut tower and axle tube is greater on the left wheel, turn the ram counterclockwise (as viewed from the ram end of the cylinder).
- If distance between the strut tower and axle tube is greater on the right wheel, turn the ram clockwise (as viewed from the ram end of the cylinder).

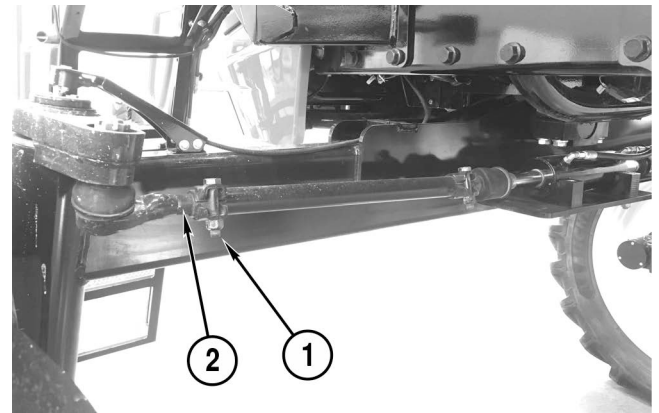

**Measure and Adjust Toe-In
(120" to 160" Adjustable Axles)**

NOTICE: On adjustable axle machines, the steering must be re-phased before measuring or adjusting the toe-in.

Rephase the Steering

NOTE: This process will be easier with warm oil. Operate the engine at 1000 rpm and make sure the hydraulic fluid is at operating temperature.

Safely lift the front wheels off the ground.

Turn the wheel to the right extreme and continue to turn 100 complete revolutions.

Turn the wheel to the left extreme and continue to turn 100 complete revolutions.

Adjust the steering cylinder rams by turning the wheel to the left or to the right until they have an equal amount of ram protruding.

Measure Tie Rods

Make sure the ball joints of the tie rod end are fully seated in the taper.

Measure the distance that the steering cylinder ram is extended (1) on the left and right wheel from the start of the threads to the face of the bar. The measurements must be equal and between 3.75 in. [95.25 mm] and 4.125 in. [104.7 mm]. Adjust the tie rods if necessary.

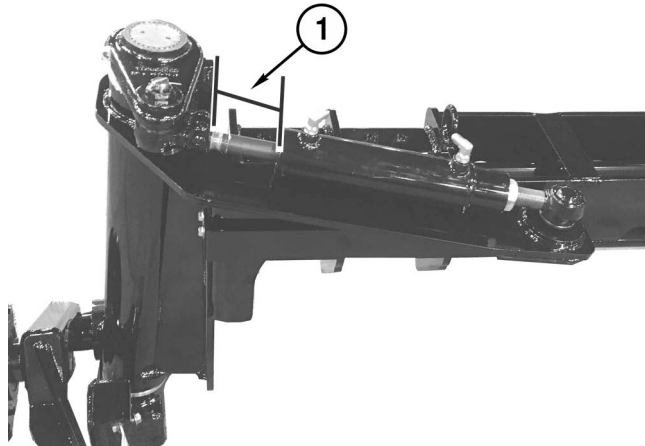

Measure Toe-in

Safely lift the front of the Apache Sprayer so the front tires are slightly off of the ground.

Turn the steering wheel so the front wheels are pointing straight.

Measure and note the distance (1) from the center of the right hub to the front of the left rim.

Measure and note the distance (2) from the center of the right hub to the rear of the left rim.

NOTE: Ladder not shown.

If distance (1) is 0.1875 in. [4.8 mm] less than distance (2), the toe-in is correct for the right wheel. If the toe-in is not correct, it must be adjusted.

Repeat the steps, measuring from the left hub to the right rim (3&4), to measure toe-in for the right wheel.

Adjust the toe-in on each wheel until it meets specification.

NOTE: The ladder is secured in upright position for visibility.

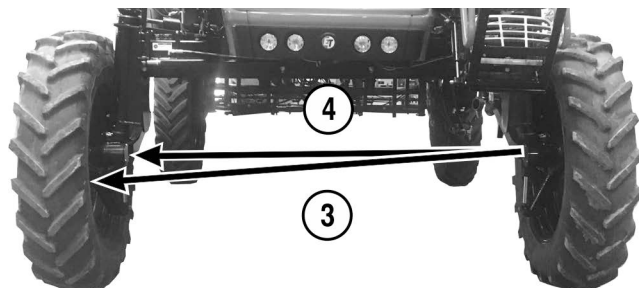
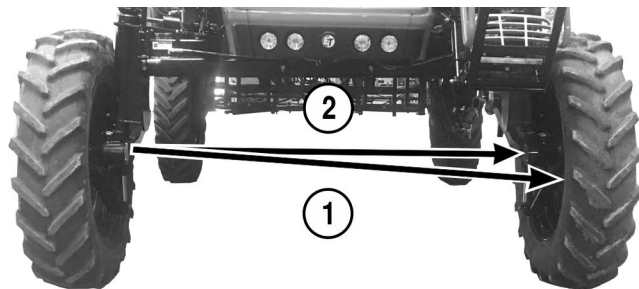

Adjust Toe-in

Toe-in adjustments should be made at the ram end of the steering cylinder.

Loosen the nut and bolt on the tie rod clamp (1).

Use a wrench on the end of the ram (2) to increase or decrease toe-in.

Final Check Toe-in

Lower the machine to the ground and check the distance from wheel to wheel.

The measurement from the rear of the right wheel to the rear of the left wheel should be between 0.3125 in. [9.5 mm] and 0.4375 [11 mm] greater than the measurement from the front of the right wheel to the front of the left wheel.

If correct, tighten all hardware.

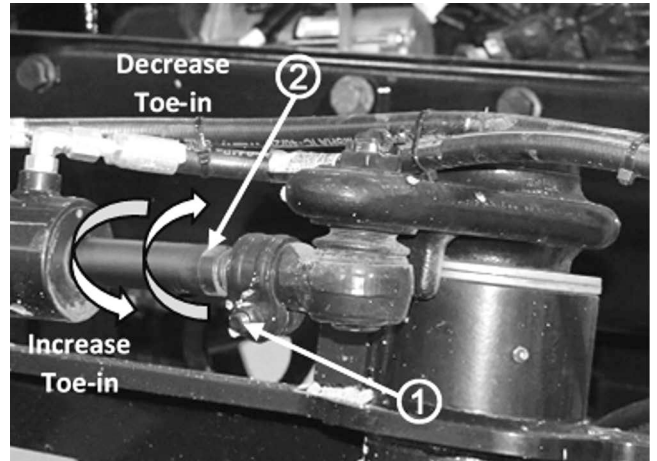

Change Engine Safety Air Filter

NOTICE: DO NOT attempt to clean the engine safety air filter. ALWAYS replace with a new filter.

The engine safety air filter is mounted in the engine compartment, above the engine and toward the cab. It is in the same housing as the primary engine air filter.

Lift up the plastic latch (1) and rotate the round end of the housing to the unlock position (2).

Pull off the end (3).

NOTICE: DO NOT leave the intake opening uncovered. If not replacing the filter immediately, cover the opening to prevent dirt and debris entering the intake system.



Slide out the primary air filter and set it aside. Slide out the engine safety air filter and discard.

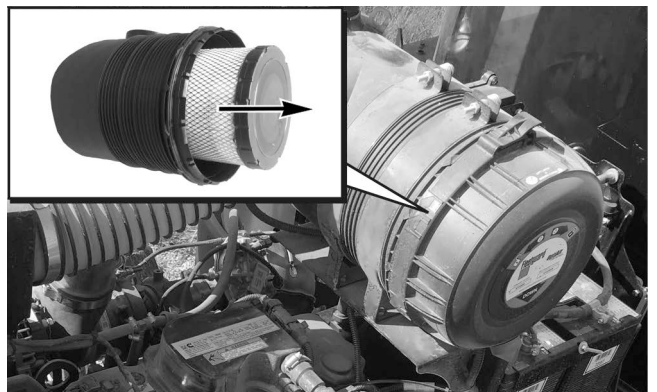

Install the new engine safety air filter by sliding into the round housing.

- Engine Safety Air Filter
Part Number: 230512002

Install the primary filter by sliding it over the safety air filter.

Reinstall the housing end cap by sliding it onto the housing with the drain oriented downward (1) and twisting clockwise to the lock position.

NOTE: The drain should be at the 6:00 position after installation. If not, remove the end cap, clock it properly, and reinstall.



Winterize Wet System

The product tank and wet system must be flushed before winterizing. See “Flushing Product Tank” on page 4-25.

Open the product tank fill valve, rinse tank valve, and Rotoflush valve to drain any remaining water in the tanks and Rotoflush line.

Close the rinse tank valve, and sump valve.

Remove end caps and set all boom sections to the ON position.

Turn agitation OFF by pressing the button for Agitation/Rotoflush valve (1) to OFF (valve closed).

Connect a compressed air line to the main fill valve (2). Apply compressed air at 40 psi [2.7 bar] to blow out the wet system and booms.

Use the Viper 4 to cycle the boom sections off and on several times to purge water from around the valves.

Disconnect the air line and close the product fill valve.

NOTICE: Drain the rinse tank, hand rinse tank, and injection tank, if equipped, to prevent damage during storage.

Remove all boom section strainers (1) and the product strainer.

Reinstall the strainer bowls.

Store the strainers in a warm, dry location.

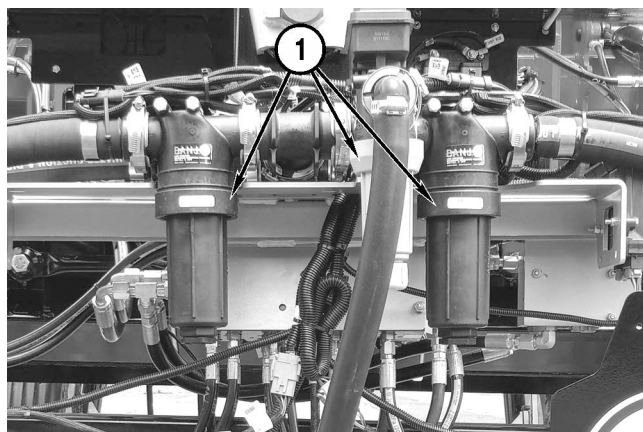
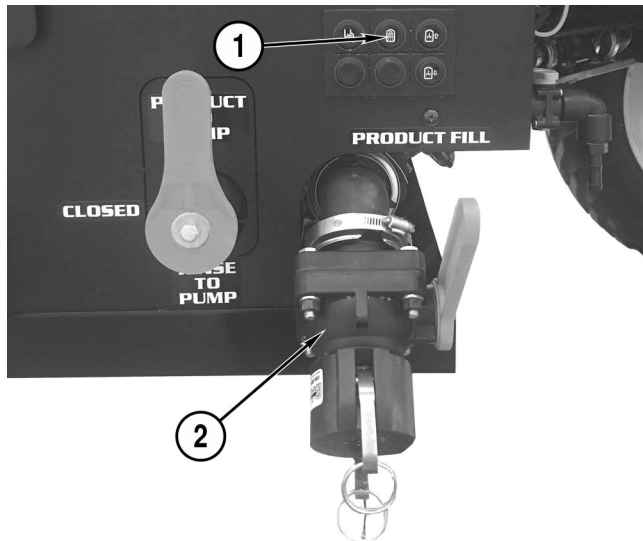

Pour approximately 20 gallons [76 liters] of RV anti-freeze into the product tank.

NOTICE: Boom lengths over 60 ft will require more than 20 gallons [76 liters] of antifreeze.

Pour 1 gallon [4 liters] of RV antifreeze into the rinse tank.

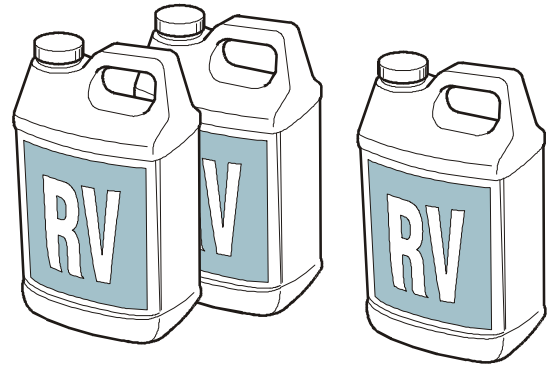

Repeatedly open and close the sump valve (1) and rinse tank/product valve (2), to allow the antifreeze to surround the ball valves.

A 2 inch fill is shown. For a 3 inch fill, push the rinse/spray button.

Close the rinse tank valve (2) and open the sump valve (1).

A 2 inch fill is shown. For a 3 inch fill, push the rinse/spray button.

Except for one nozzle at the end of each boom section, turn off all the nozzle bodies.

Open all manual valves halfway and then close to allow any trapped water to escape.

NOTICE: DO NOT run the product pump dry. Damage to the pump seals will result. DO NOT intentionally dead-head the pump with high pressures. Damage to the pump seals will result.

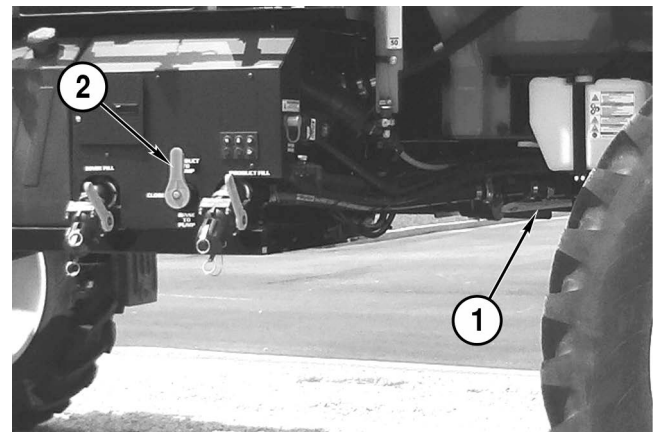

Start the engine.

Unfold and lower the booms as far as possible.

Using the Viper 4 monitor set all boom sections to the OFF position and press the agitation increase button (1).

Set the product pump switch (2) to the ON position.

Press the agitation decrease button (3) to turn agitation off. One at a time, set the boom sections to the ON position until antifreeze flows from the open nozzle in each boom section.

Turn the boom sections OFF.

Set the product pump switch (2) to the OFF position.

NOTE: Excess antifreeze may be left in the sprayer.



Every 1000 Hours or Yearly

The following services must be performed after every 1000 hours of operation or yearly.

Change Hydraulic Fluid

The hydraulic fluid drain plug (1) is located on the hydraulic fluid reservoir, between the cab and the product tank.

Remove the hydraulic fluid drain plug (1) from the bottom of the reservoir and drain the fluid into a suitable container with a capacity of approximately 23 gallons [87 liters]. Dispose of the fluid properly.

Install the drain plug (1).

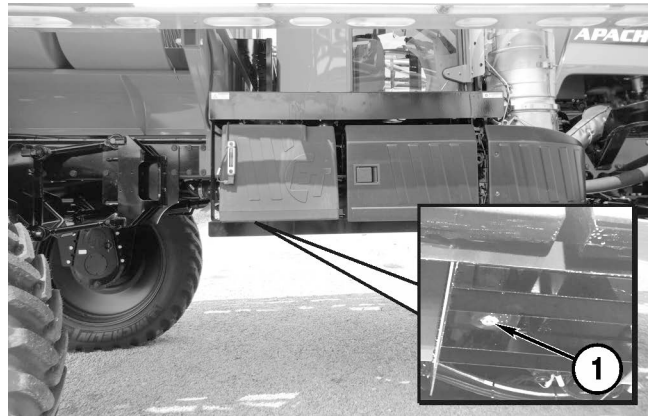

NOTICE: Use only Lucas Universal Hydraulic Fluid or equivalent for the Apache Sprayer hydraulic system.

Remove the hydraulic fluid reservoir cap (1) and fill with Lucas Universal Hydraulic Fluid or equivalent.

- Hydraulic Fluid Reservoir Capacity:
23 gallons [87 liters]

Use the sight glass (2) to check the fluid level. See “Check Hydraulic Fluid Level” on page 5-15.

NOTE: The sight glass also shows hydraulic fluid temperature.

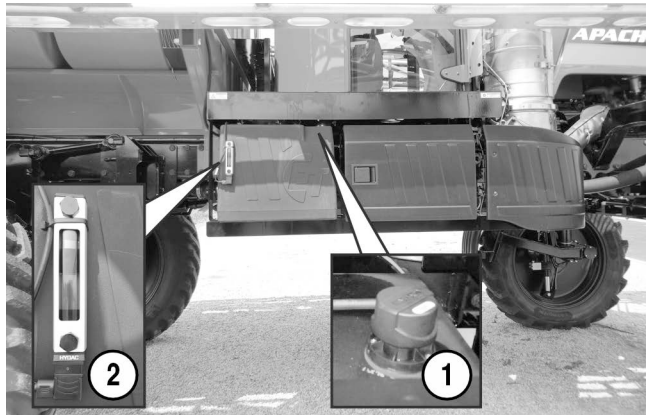

Change DEF Suction Filter

The DEF suction filter is located in the DEF tank which is located under the walking surface in front of the fuel tank.

To reduce the possibility of injury from hot coolant spray, turn the engine off and, with locking pliers, pinch the DEF heater hoses closed. The heater hoses are a larger diameter hose and connect to the larger fittings on the unit.

Note hose location for assembly.

Disconnect all the hoses and drain the fluids into a suitable container. Dispose the fluids properly.

Remove the six bolts (1) and retaining ring (2) that hold the DEF level/temperature unit (3) in place.

Lift the unit out of the tank and remove the clip from the inlet port of the DEF filter.

Remove the DEF filter and inspect. If dirty or any cracks are present, discard and replace.

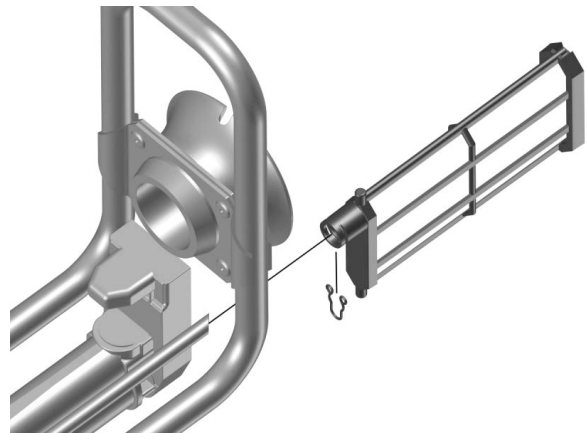
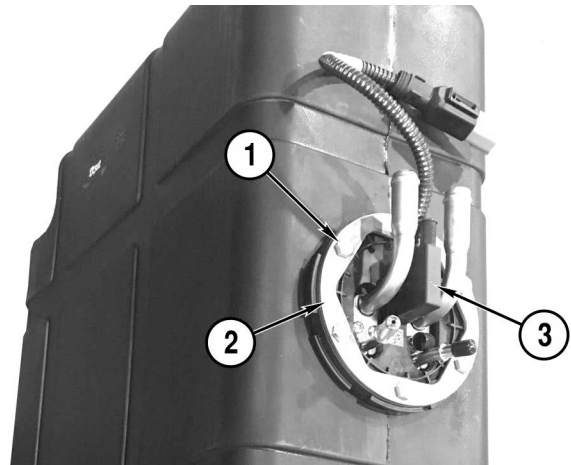

Install the o-ring (1) in its notch on the DEF tank pickup tube.

Insert DEF tank filter inlet port into the pickup tube. Install the clip over the notch on the filter inlet port.

NOTICE: Consult Cummins parts service for 40 micron filter and o-ring replacement.

Place the DEF level/temperature unit back into the tank and orient the hose barb as they were originally.

Install the retaining ring and mounting screws. Tighten the bolts to 80 in-lb [9 N•m]

Connect the hoses and release to clamps on the heater hoses.

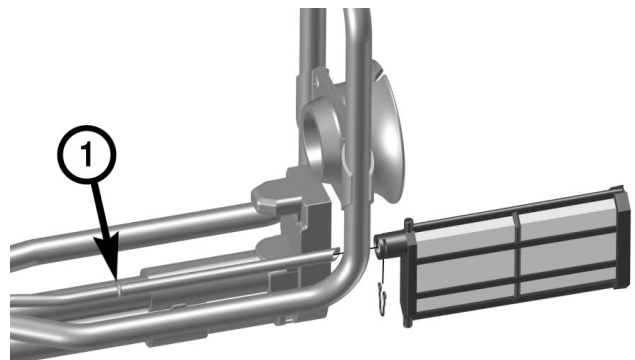

Every 4500 Hours or 3 Years

The following services must be performed after every 4500 hours or 3 years of operation.

Change DEF Supply Module Filter

Remove the DEF filter cap (1) and filter from the supply module.

Install the new filter and replace the cap.

- DEF Supply Module Filter
Part Number: 241000009

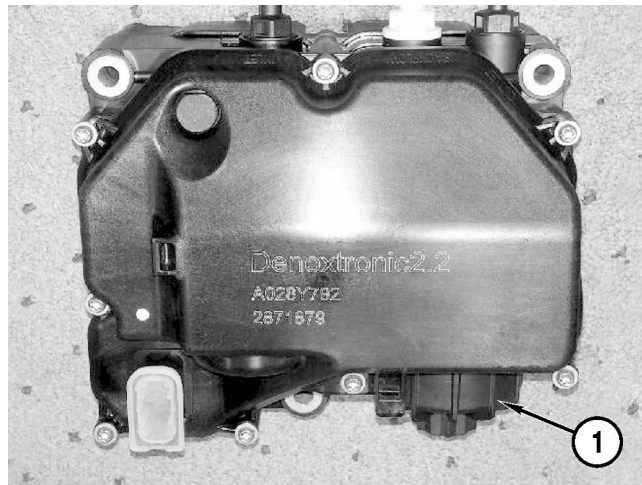

APACHE™

CHAPTER 6

TORQUE VALUE CHARTS

Fittings

ALWAYS tighten fittings to the values below unless a different torque value is specified.

Make sure fitting threads are clean and threads are engaged properly.

All torque values are adopted from SAE J514 and SAE J1453.

Size Chart

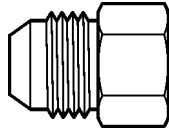
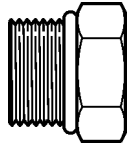
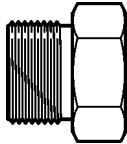
SAE Dash Size			
	SAE (JIC) 37° Flare Thread	O-ring Style Straight Thread	Face Seal
	Size	Size	Size
2	5/16-24	5/16-24	----
3	3/8-24	3/8-24	----
4	7/16-20	7/16-20	9/16-18
5	1/2-20	1/2-20	----
6	9/16-18	9/16-18	11/16-16
8	3/4-16	3/4-16	13/16-16
10	7/8-14	7/8-14	1-14
12	1 1/16-12	1 1/16-12	1 3/16-12
14	1 3/16-12	1 3/16-12	----
16	1 5/16-12	1 5/16-12	1 7/16-12
20	1 5/8-12	1 5/8-12	1 11/16-12
24	1 7/8-12	1 7/8-12	2-12
32	2 1/2-12	2 1/2-12	----



Fitting Torque Value Chart

SAE Dash Size	TORQUE					
	SAE 37° Flare		O-ring Straight Thread		Face Seal	
	lb-ft	N•m	lb-ft	N•m	lb-ft	N•m
2	4	5	4	5	----	----
3	8	11	9	12	----	----
4	12	16	16	22	18	25
5	15	20	22	30	---	---
6	18	25	35	48	27	37
8	37	50	60	82	40	54
10	48	65	105	143	63	86
12	74	100	140	190	92	125
14	88	120	184	250	----	----
16	100	135	221	300	122	165
20	133	180	258	350	147	200
24	166	225	317	430	166	225
32	236	320	----	----	----	----





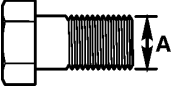
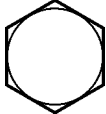

Bolts

ALWAYS tighten bolts to the values below unless a different torque value is specified. Fasteners must ALWAYS be replaced with the same grade. Make sure bolt threads are clean and threads are engaged properly. All torque values are derived from Machinery’s Handbook, Mechanical Engineering Design, SAE J1701 and SAE J1701M.

SAE Series Torque Value Chart

 A = Bolt Diameter		 SAE Grade 2 (No Markings)			 SAE Grade 5 (3 Radial Dashes)			 SAE Grade 8 (6 Radial Dashes)		
A Diam. (In) and thread pitch	Wrench Size	FASTENER COATING								
		SAE Grade 2 Torque lb-ft [N•m]			SAE Grade 5 Torque lb-ft [N•m]			SAE Grade 8 Torque lb-ft [N•m]		
		Dry	Zinc Plated	Lubri- cated	Dry	Zinc Plated	Lubri- cated	Dry	Zinc Plated	Lubricated
1/4-20	7/16"	6 [8]	5 [7]	4 [5]	8 [11]	7 [9]	6 [8]	12 [17]	11 [15]	9 [12]
1/4-28	7/16"	6 [8]	5 [7]	4 [5]	10 [13]	9 [12]	7 [9]	14 [18]	12 [17]	10 [13]
5/16-18	1/2"	11 [15]	10 [13]	8 [11]	17 [23]	15 [20]	13 [18]	25 [34]	22 [30]	18 [24]
5/16-24	1/2"	12 [17]	11 [15]	9 [12]	19 [26]	17 [23]	14 [19]	27 [37]	24 [32]	20 [27]
3/8-16	9/16"	20 [27]	18 [24]	15 [20]	31 [42]	28 [38]	23 [31]	44 [60]	39 [53]	38 [52]
3/8-24	9/16"	23 [31]	20 [27]	17 [23]	35 [47]	31 [42]	26 [35]	49 [67]	44 [60]	37 [50]
7/16-14	5/8"	32 [43]	29 [39]	24 [32]	49 [66]	44 [60]	37 [50]	70 [95]	63 [85]	61 [83]
7/16-20	5/8"	36 [48]	32 [43]	27 [37]	55 [75]	50 [68]	41 [56]	78 [106]	70 [95]	58 [79]
1/2-13	3/4"	49 [66]	44 [60]	37 [50]	75 [102]	68 [92]	57 [77]	106 [144]	96 [130]	93 [126]
1/2-20	3/4"	55 [75]	49 [66]	41 [56]	85 [115]	76 [103]	64 [87]	120 [163]	108 [146]	105 [142]
9/16-12	13/16"	70 [95]	63 [85]	55 [75]	110 [149]	100 [136]	80 [108]	150 [203]	130 [176]	110 [149]
9/16-19	13/16"	78 [106]	70 [95]	60 [81]	121 [164]	110 [149]	90 [122]	171 [232]	157 [213]	130 [176]
5/8-11	15/16"	97 [131]	87 [118]	73 [99]	150 [203]	135 [183]	113 [153]	212 [287]	191 [259]	159 [216]
5/8-18	15/16"	110 [149]	99 [134]	82 [111]	170 [230]	153 [207]	127 [172]	240 [325]	216 [293]	180 [244]
3/4-10	1 1/8"	172 [233]	155 [210]	129 [175]	267 [362]	240 [325]	200 [271]	376 [510]	339 [460]	282 [382]
3/4-16	1 1/8"	192 [261]	173 [235]	144 [195]	297 [403]	267 [362]	223 [302]	420 [570]	378 [513]	315 [427]
7/8-9	1 5/16"	167 [226]	150 [203]	125 [169]	429 [582]	386 [523]	322 [437]	606 [822]	545 [739]	455 [627]
7/8-14	1 5/16"	184 [250]	165 [224]	138 [187]	474 [642]	426 [578]	355 [481]	669 [907]	602 [816]	677 [918]
1/8	1 1/2"	250 [339]	225 [305]	187 [254]	644 [873]	579 [785]	483 [665]	909 [1232]	818 [1109]	681 [923]
1-12	1 1/2"	274 [371]	246 [334]	205 [278]	722 [979]	634 [860]	528 [716]	1020 [1383]	895 [1213]	746 [1011]

Metric Series Torque Value Chart

 Diameter and Thread Pitch (Millimeters)	Wrench Size	 Metric Grade 8.8		 Metric Grade 10.9		 Metric Grade 8.8		 Metric Grade 10.9		 Diameter and Thread Pitch (Millimeters)
		Course Thread				Fine Thread				
		Metric 8.8		Metric 10.9		Metric 8.8		Metric 10.9		
		N•m	lb-ft	N•m	lb-ft	N•m	lb-ft	N•m	lb-ft	
6 x 1.0	10	8	6	11	8	8	6	11	8	6 x 1.0
8 x 1.25	13	20	15	27	20	21	16	29	22	8 x 1.0
10 x 1.5	16	39	29	54	40	41	30	57	42	10 x 1.25
12 x 1.75	18	68	50	94	70	75	55	103	76	12 x 1.25
14 x 2.0	21	109	80	151	111	118	87	163	120	14 x 1.5
16 x 2.0	24	169	125	234	173	181	133	250	184	16 x 1.5
18 x 2.5	27	234	172	323	239	263	194	363	268	18 x 1.5
20 x 2.5	30	330	244	457	337	367	270	507	374	20 x 1.5
22 x 2.5	34	451	332	623	460	495	365	684	505	22 x 1.5
24 x 3.0	36	571	421	790	583	623	459	861	635	24 x 2.0
30 x 3.0	46	1175	867	1626	1199	1258	928	1740	1283	30 x 2.0

APACHE™

CHAPTER 7 TROUBLESHOOTING

Apache Sprayer Troubleshooting Symptoms and Solutions

If your issue was not resolved by using the troubleshooting guide, contact your dealer for more help.

SYMPTOM	SOLUTION
Parking brake will not engage.	Check electrical coil on hydraulic junction block, under cab, for power. Check hose connections to brake canister on transmission.
Apache Sprayer will not move forward or backward.	Parking brake is engaged. Check electrical connections on parking brake and transmission.
Constant alarm sounds when Apache Sprayer moves forward or backward.	Check transmission fluid level. Check wire connection at sending unit. Check transmission temperature sensor.
Apache Sprayer will not move forward.	Check driveshaft. Check transmission fluid level. Check electrical connections on transmission.
Apache Sprayer will not move backward.	Check driveshaft. Check transmission fluid level. Check electrical connections on transmission.
Engine will not start.	Confirm battery disconnect button is "ON". Check diesel fuel level. Check neutral safety relay.
Apache Sprayer steering does not work.	Check hydraulic fluid level. Check for hydraulic fluid leaks. Check steering column coupling on steering motor.
Transmission will not shift gears.	Check transmission fluid level.
Apache Sprayer brakes do not work.	Check brake hoses for leaks. Check push rods on master cylinder.

SYMPTOM	SOLUTION
No power to console in cab.	Check electrical connections in right rear corner of cab, near fuse box.
Road and service lights do not work.	<p>Confirm light buttons are “ON”.</p> <p>Check electrical connections to the light pad, cabin power distribution module, and the firewall distribution module.</p> <p>Check for power at light bulbs.</p> <p>Check appropriate fuses.</p>
Turn signals and/or flashers do not work.	<p>Confirm lever/switch in “ON” position.</p> <p>Check electrical connections at light housings.</p> <p>Check for power at light housings.</p>
Booms will not fold or unfold.	<p>Confirm engine is running.</p> <p>Check hydraulic fluid level.</p> <p>Confirm booms are greased properly.</p> <p>Check for hydraulic fluid leaks.</p> <p>Check electrical connections in cab and at boom manifold.</p>
Booms will not tilt up or down.	<p>Confirm engine is running.</p> <p>Check hydraulic fluid level.</p> <p>Check for hydraulic fluid leaks.</p> <p>Check electrical connections in cab and at boom manifold.</p>
Apache Sprayer will not spray.	<p>Confirm engine is running.</p> <p>Confirm product in product tank.</p> <p>Confirm ball valves from tank to product pump are open.</p> <p>Confirm product pump is turned on.</p> <p>Check ground speed on console controller display.</p> <p>Confirm boom valves are opening. If they are not, check appropriate fuses and back rack electrical connections.</p>
Product boom valves will not turn on.	<p>Unplug electric connection at valve for 20 seconds.</p> <p>Check electrical connections in cab.</p> <p>Check fuse block in cab.</p>
Product boom valves will not turn off.	<p>Check boom valves for operation.</p> <p>Check electrical connections at boom valves.</p> <p>Check electrical connections in cab.</p> <p>Check power module in cab.</p>

SYMPTOM	SOLUTION
Seat will not raise or lower.	Check power module in cab. Check wire connections at right side of seat. Check for air leaks.
Raven monitor does not turn on.	Check power module in cab. Check electrical connections at the monitor.
Front suspension cylinder is flat.	Check hydraulic fluid level. Check hoses for leaks. Check accumulator pressure.
Rear suspension will not rise.	Check hydraulic fluid level. Check electrical connections at suspension block and switches.
Product pump will not turn on.	Confirm product pump button is on and indicator is lit. Check electrical connections at hydraulic valve block. Check electrical connections in cab.
A/C does not cool.	Confirm A/C button is "ON". Confirm fan is "ON". Check belt to compressor.
Rack still moves when rack lock is engaged.	Check voltage to solenoid at rack lock manifold. Perform clean out procedure of rack lock manifold.

APACHE™

CHAPTER 8

ELECTRICAL SYSTEM

Chassis Power Distribution Module and Relay Chart

FUSE#	FUSE TYPE	RELAY #	DESCRIPTION
F1	500A MEGA	***	Alternator Power
F2	80A MIDI	***	Auxiliary Battery Post Power
F3	250A MEGA	***	Cab / Boom Battery Power
F4	250A MEGA	K2	Cold Start Power
F5	15A ATO	K6	DEF Supply Heater Power
F6	40A ATO	K5	Starter Solenoid Power
F7	15A ATO	K8	DEF Line Heater Power
F8	20A ATO	K7	Chassis SPU Output Power
F9	10A ATO	K7	AOG Power
F10	5A ATO	K7	Engine Ignition Power
F11	15A ATO	K7	Engine A-T Sensor Power
F12	10A ATO	K7	Unused
F13	10A ATO	K7	Chassis Ignition Power
F14	25A ATO	***	HVAC Blower Power
F15	30A ATO	***	Unused
F16	7.5A ATO	***	Unused
F17	7.5A ATO	K9	Unused
F18	15A ATO	***	Chassis SPU Battery Power
F19	20A ATO	***	Chassis Light Power
F20	15A ATO	***	Drivetrain Power
F21	30A ATO	***	Engine ECU Power
F22	20A ATO	K10	Fill Station Extended Power
F23	5A ATO	K7	Cab Ignition Signal
***	***	K1,K3,K4	Battery Disconnect

Cabin Power Distribution Module and Relay Chart

FUSE#	FUSE TYPE	RELAY #	DESCRIPTION
F1	5A MINI	***	Antenna Battery Power
F2	5A MINI	Relay 1	Node Logic Power
F3	5A MINI	Relay 1	ISOBUS CAN Power
F4	5A MINI	***	HDU Battery Power
F5	20A MINI	Relay 2	CAN Switched Power
F6	5A MINI	Relay 3	Armrest Ignition Power
F7	5A MINI	Relay 3	Console Ignition Power
F8	10A MINI	***	Console Battery Power
F9	15A MINI	***	Cab SPU Battery Power
F10	10A MINI	***	Power Point Battery Power
F11	5A MINI	***	Armrest Battery Power
F12	20A MINI	Relay 3	Accessory Power
F13	10A MINI	Relay 4	Power Point Ignition Power
F14	20A MINI	Relay 4	Cab Auxiliary Ignition Power
F15	20A MINI	***	Cab Auxiliary Battery Power
F16	20A MINI	***	Front Worklight Power
F17	20A MINI	***	Rear Worklight Power
F18	20A MINI	***	Cab Roof Battery Power
F19	10A MINI	Relay 5	Steering Column Ignition Power
F20	20A MINI	Relay 5	Seat Power

Boom Power Distribution Module and Relay Chart

FUSE#	FUSE TYPE	RELAY #	DESCRIPTION
F1	15A MINI	Relay 1	Individual Nozzle Power
F2	15A MINI	Relay 2	Individual Nozzle Power
F3	15A MINI	Relay 3	Individual Nozzle Power
F4	15A MINI	Relay 4	Individual Nozzle Power
F5	15A MINI	Relay 5	Individual Nozzle Power
F6	15A MINI	Relay 6	Individual Nozzle Power
F7	30A MINI	***	Aux Battery Power
F8	15A MINI	***	AutoboombPower
F9	30A MINI	***	Aux Battery Power
F10	15A MINI	***	Product Control Power
F11	30A MINI	***	Boom Valve Power
F12	30A MINI	***	Aux Boom Valve Power

APACHE™

CHAPTER 9

WARRANTY

Apache Sprayer Warranty Registration and Policy For all 2025 Model Year

Apache Sprayer Machine Warranty Registration

This is performed by the selling Apache Sprayer dealer and must be completed within fourteen (14) calendar days from delivery to end user.

Apache Sprayer Engine Warranty Registration

This is performed by the selling Apache Sprayer dealer: To register the Cummins engine for warranty first have the engine serial number, then go to www.cummins.com click on “product registration” read the terms and conditions. If you agree with the terms and conditions, then click on “I accept”, and follow the instructions to register. This must be completed within fourteen (14) calendar days from delivery to end user. (When registering the sprayer on www.etdealer.com, a link is provided to the Cummins website and all of the customer information auto-fills from the [etdealer.com](http://www.etdealer.com) registration form.)

APACHE SPRAYER LIMITED WARRANTY POLICY

Equipment Technologies (hereinafter called ET) warrants each new Apache Sprayer to be free from defects in materials and workmanship for a period of five (5) years or two thousand (2000) hours, whichever occurs first, from the warranty start date, with the exclusions listed herein. Under no circumstances does this limited warranty cover any merchandise or component parts, which, in the sole opinion of ET, have been subject to negligence, misuse, improper storage, alteration, accident, or if repairs have been made with parts other than those manufactured, supplied, and/or authorized by ET. Under no circumstances are component parts warranted against normal wear and tear.

There is no warranty on glass, parking brake pads or discs, brake linings, filters, oils, product pump seals, product pump bearings, rubber product hoses, pressure gauges or ground engaging accessories such as auto boom wheels and related bearings, shocks, or springs.

Components, systems, or accessories that are installed by the dealer and were not installed by ET when the machine was originally manufactured are not covered by this warranty.

First and Second Year - Limited warranty covers the total machine for the first two years from warranty start date or one thousand (1000) hours whichever occurs first, for parts, labor, and mileage. Under no circumstances does this limited warranty cover any merchandise or component parts, which, in the sole opinion of ET, have been subject to negligence, misuse, improper storage, alteration, accident, or if repairs have been made with parts other than those manufactured, supplied, and/or authorized by ET. For engine, tire, and battery warranty please see below.

Years Three through Five - Limited warranty covers some power train and chassis components for parts only from the warranty start date or two thousand (2000) hours whichever comes first. The following components are covered under years three through five of warranty: Transmission and its internal components (excludes park brake components, harness, electrical components, main drive shafts and u-joints), differential and its internal components, front axle assembly (excludes seals, bearings, wear pads, suspension cylinder (i.e. front strut), outer flex, hubs, accumulator, and steering cylinders), frame rails, engine bolster, rear axle assembly (excludes wear pads, output drive shafts, and rear suspension components), planetary and its internal components (excludes bearings, seals, and o-rings), drop boxes and their internal components (excludes bearings and seals), frame cross members and any bracket that bolts directly to the frame rails. This portion of coverage is subject to all listed conditions but further excludes oil, seals, gaskets and leakage, and all park brake components.

Engine Warranty - The limited engine warranty is covered by Cummins Inc. for two (2) years or two thousand (2000) hours from the warranty start date, whichever comes first. ET does warrant the a/c compressor and alternator for first and second year. Cummins Inc. warrants all other bolt on and engine components. See engine warranty for complete details.

Tires - Warranty for Michelin tires will be handled through your local authorized Michelin dealer. Please contact ET if you have any questions.

Batteries - Batteries are warranted for thirty (30) months through NAPA auto part stores.

ET's obligation under this limited warranty is limited to repairing or replacing free of charge to the original purchaser, at a location designated by ET, any part that in ET's sole judgment, shows evidence of defect or improper workmanship, provided that the part is returned to ET within thirty (30) calendar days of the issue of an automatically or manually generated RMA. Parts must be returned through the authorized selling dealer, transportation charges prepaid. All returned parts must be clean from all chemicals and/or oils.

ET's obligation under this limited warranty is in lieu of all other warranties or representations, expressed or implied, and specifically excludes any obligations or liability for loss of crops, losses caused by harvest delays or any expense or loss of labor, supplies, rental equipment, and all incidental or consequential damages. The replacement of parts and/or repair is the exclusive remedy under this limited warranty. ET reserves the right to repair or replace any defective part or parts. No person is authorized to give any other warranties or to assume any other liability on ET's behalf. This limited warranty is void if ET's limited warranty policy maintenance standards are violated.

ET makes NO warranty of merchantability or fitness for a particular purpose.

All inquires about this warranty policy should be addressed to:

Warranty Department • 455 Merriman Road • Mooresville, IN • 46158

Telephone: 317-834-4500

APACHE™

CHAPTER 10

MAINTENANCE LOG

_____ Season

Check and inspect each of the following items on your Apache Sprayer. Put the date on the line next to each item as it is completed.

	Check front suspension cylinders for leaks around the seal.
	Grease the front axle assembly including all king-pins and center pivot pin. Check all front axle bolts for proper torque.
	Clean radiator and cooling package of all debris, check all radiator and cooling package hoses to make sure they are tight and not leaking.
	Change engine oil and replace filters.
	Service fuel system and replace filters.
	Service transmission; change oil and replace filter, remove suction screen, clean and inspect for damage.
	Replace cab filters.
	Remove and replace engine air filters, check intake clamps to make sure they are tight.
	Grease the U-joints on all driveshafts and inspect each U-joint for wear and missing caps.
	Inspect carrier bearing on the front driveshaft for wear and damaged rubber.
	Service rear differential.
	Grease the rear axle assembly and check all rear axle bolts for proper torque.
	Service the hydraulic system. Check the oil, check the filter and replace if needed.
	Remove all product screens from strainers, clean and inspect for damage. Replace as needed.
	Fold booms out and adjust and grease.
	Inspect booms for cracks, breaks, and worn hinge points.

_____ **Season**

Check and inspect each of the following items on your Apache Sprayer. Put the date on the line next to each item as it is completed.

	Check front suspension cylinders for leaks around the seal.
	Grease the front axle assembly including all king-pins and center pivot pin. Check all front axle bolts for proper torque.
	Clean radiator and cooling package of all debris, check all radiator and cooling package hoses to make sure they are tight and not leaking.
	Change engine oil and replace filters.
	Service fuel system and replace filters.
	Service transmission; change oil and replace filter, remove suction screen, clean and inspect for damage.
	Replace cab filters.
	Remove and replace engine air filters, check intake clamps to make sure they are tight.
	Grease the U-joints on all driveshafts and inspect each U-joint for wear and missing caps.
	Inspect carrier bearing on the front driveshaft for wear and damaged rubber.
	Service rear differential.
	Grease the rear axle assembly and check all rear axle bolts for proper torque.
	Service the hydraulic system. Check the oil, check the filter and replace if needed.
	Remove all product screens from strainers, clean and inspect for damage. Replace as needed.
	Fold booms out and adjust and grease.
	Inspect booms for cracks, breaks, and worn hinge points.
	Inspect boom plumbing for worn hoses and bad nozzles.
	Fill and flush the wet system with clean water. Check boom pressure and agitation to validate functionality.
	Inspect all hydraulic hoses for rubs, worn spots and leaks.
	Inspect all hydraulic cylinders for leaks and proper operation.
	Inspect wiring harnesses for rub points.
	Verify Controller calibrations:

_____ **Season**

Check and inspect each of the following items on your Apache Sprayer. Put the date on the line next to each item as it is completed.

	Check front suspension cylinders for leaks around the seal.
	Grease the front axle assembly including all king-pins and center pivot pin. Check all front axle bolts for proper torque.
	Clean radiator and cooling package of all debris, check all radiator and cooling package hoses to make sure they are tight and not leaking.
	Change engine oil and replace filters.
	Service fuel system and replace filters.
	Service transmission; change oil and replace filter, remove suction screen, clean and inspect for damage.
	Replace cab filters.
	Remove and replace engine air filters, check intake clamps to make sure they are tight.
	Grease the U-joints on all driveshafts and inspect each U-joint for wear and missing caps.
	Inspect carrier bearing on the front driveshaft for wear and damaged rubber.
	Service rear differential.
	Grease the rear axle assembly and check all rear axle bolts for proper torque.
	Service the hydraulic system. Check the oil, check the filter and replace if needed.
	Remove all product screens from strainers, clean and inspect for damage. Replace as needed.
	Fold booms out and adjust and grease.
	Inspect booms for cracks, breaks, and worn hinge points.
	Inspect boom plumbing for worn hoses and bad nozzles.
	Fill and flush the wet system with clean water. Check boom pressure and agitation to validate functionality.
	Inspect all hydraulic hoses for rubs, worn spots and leaks.
	Inspect all hydraulic cylinders for leaks and proper operation.
	Inspect wiring harnesses for rub points.
	Verify Controller calibrations:

_____ **Season**

Check and inspect each of the following items on your Apache Sprayer. Put the date on the line next to each item as it is completed.

	Check front suspension cylinders for leaks around the seal.
	Grease the front axle assembly including all king-pins and center pivot pin. Check all front axle bolts for proper torque.
	Clean radiator and cooling package of all debris, check all radiator and cooling package hoses to make sure they are tight and not leaking.
	Change engine oil and replace filters.
	Service fuel system and replace filters.
	Service transmission; change oil and replace filter, remove suction screen, clean and inspect for damage.
	Replace cab filters.
	Remove and replace engine air filters, check intake clamps to make sure they are tight.
	Grease the U-joints on all driveshafts and inspect each U-joint for wear and missing caps.
	Inspect carrier bearing on the front driveshaft for wear and damaged rubber.
	Service rear differential.
	Grease the rear axle assembly and check all rear axle bolts for proper torque.
	Service the hydraulic system. Check the oil, check the filter and replace if needed.
	Remove all product screens from strainers, clean and inspect for damage. Replace as needed.
	Fold booms out and adjust and grease.
	Inspect booms for cracks, breaks, and worn hinge points.
	Inspect boom plumbing for worn hoses and bad nozzles.
	Fill and flush the wet system with clean water. Check boom pressure and agitation to validate functionality.
	Inspect all hydraulic hoses for rubs, worn spots and leaks.
	Inspect all hydraulic cylinders for leaks and proper operation.
	Inspect wiring harnesses for rub points.
	Verify Controller calibrations:

_____ **Season**

Check and inspect each of the following items on your Apache Sprayer. Put the date on the line next to each item as it is completed.

	Check front suspension cylinders for leaks around the seal.
	Grease the front axle assembly including all king-pins and center pivot pin. Check all front axle bolts for proper torque.
	Clean radiator and cooling package of all debris, check all radiator and cooling package hoses to make sure they are tight and not leaking.
	Change engine oil and replace filters.
	Service fuel system and replace filters.
	Service transmission; change oil and replace filter, remove suction screen, clean and inspect for damage.
	Replace cab filters.
	Remove and replace engine air filters, check intake clamps to make sure they are tight.
	Grease the U-joints on all driveshafts and inspect each U-joint for wear and missing caps.
	Inspect carrier bearing on the front driveshaft for wear and damaged rubber.
	Service rear differential.
	Grease the rear axle assembly and check all rear axle bolts for proper torque.
	Service the hydraulic system. Check the oil, check the filter and replace if needed.
	Remove all product screens from strainers, clean and inspect for damage. Replace as needed.
	Fold booms out and adjust and grease.
	Inspect booms for cracks, breaks, and worn hinge points.
	Inspect boom plumbing for worn hoses and bad nozzles.
	Fill and flush the wet system with clean water. Check boom pressure and agitation to validate functionality.
	Inspect all hydraulic hoses for rubs, worn spots and leaks.
	Inspect all hydraulic cylinders for leaks and proper operation.
	Inspect wiring harnesses for rub points.
	Verify Controller calibrations:



WWW.ETSPRAYERS.COM